

“Plug and play” modular façade construction system for building renovation to achieve nearly Zero Energy Building (nZEB)

Mr. Jorge Torres¹, Dr. Roberto Garay Martinez², Mr. J. Ignacio Torrens-Galdiz³, Ms. Amaia Uriarte⁴, Mr. Alessandro Pracucci⁵, Mr. Oscar Casadei⁶, Mrs. Sara Magnani⁷, Ms. Noemi Arroyo⁸, Mr. Angel M. Cea⁹ ^{1,2,3,4}TECNALIA, Basque Research and Technology Alliance (BRTA), Derio, Spain

jorge.torres, roberto.garay, ignacio.torrens, amaia.uriarte@tecnalia.com

^{5,6,7}Focchi Spa, Poggio Torriana, Italy
a.pracucci, o.casadei, s.magnani@focchi.it

⁸Durango Eraikitzen S.A.U., Durango, Spain
narroyo@durango.eus

⁹MAAB Arquitectura y Urbanismo SLP. Bilbao, Spain
angel@maab.info

Abstract: Following energy performance improvement policies, there is a need for the massive renovation of the European building stock. The prevalence of multi-rise buildings with concrete structure and poor thermal performance offers a significant opportunity for renovation packages that facilitate the improvement of the building fabric, with its insulation, air-tightness and integration of building services and solar technologies. The RenoZEB project develops a "plug and play" modular facade construction system answering to this need. This prefabricated plug and play modular system has been tested by reproducing the holistic methodology and new technologies in the market by means of real and virtual demonstrators. The applicability and effectiveness of the methodology has been tested by means of a full-scale mock-up system has been constructed and installed in the KUBIK by Tecnalia test facility. The design, construction, manufacture & installation cycle has been tested. Its applicability for a real construction project for a multi-rise residential building in Spain is presented.

Keywords: Building Retrofit; Energy performance; Industrialized Construction. Building envelope, H2020,

1. Introduction

As Pérez-Lombard (2008) has pointed out, the building sector is responsible for 40% of primary energy consumption in Europe and about 33% of total GHG (greenhouse gases) emissions according to United Nations Environment Programme (2015).

In this context of unsustainable energy consumption, the strategy proposed by the European Commission "Europe 2020" which aims to achieve "smart, sustainable and inclusive growth" has become the main continental initiative that defines the roadmap to improve this situation. Three main objectives

Imaginable Futures: Design Thinking, and the Scientific Method. 54th International Conference of the Architectural Science Association 2020, Ali Ghaffarianhoseini, et al (eds), pp. 865–874. © 2020 and published by the Architectural Science Association (ANZAScA).

Jorge Torres, Dr. Roberto Garay Martinez, J. Ignacio Torrens-Galdiz, Amaia Uriarte, Alessandro Pracucci, Oscar Casadei, Sara Magnani, Noemi Arroyo, Angel M. Cea

have been defined: the reduction of GHG emissions, the increase of renewable energies and the improvement of energy efficiency. The EU Directives (Council Directive 2002/91/EC and 2010/31/EU), and the EU Construction Products Regulation (2011), contain a number of basic requirements applied specifically to the building sector for the "Energy Economy and Heat Retention".

In Europe, many studies such as Ravetz (2008) state that 75% of the dwellings estimated for 2050 have already been built. About 40% of Europe's residential building stock was constructed before 1960 when energy building regulations were very limited. As Economidou et al. (2011) has pointed out, the majority of these buildings are apartment blocks. These aged and poor-performing buildings represent an opportunity for building renovation to achieve the aforementioned objectives. This is also the case for Spain, where, although a recently deployed building code CTE (2019) requires NZEB performance for new buildings, its building stock was mainly constructed before the initial building codes with some energy requirements, NBE CT presented in (1979) and a renovation rate of about 1%, as UE (2019) has pointed out.

The most common renovation technique involves adding insulation on the external part of the building envelope on site. This process is considered to require extensive labor on site and presents high damage risks for damage because of being exposed to different conditions (outdoor force, weather conditions). The use of a modular "Plug and play" façade can diminish these risks and reduces the time needed during the renovation process on site (fewer disturbances for the inhabitants).

HVAC systems installed in the existing buildings are often difficult to retrofit since their installations are spread through the whole building having indoor and outdoor components. To solve this, many studies suggest the use of prefabricated modules. Apartment blocks have commonly a lack of useful surface for the installation of solar generation systems on the roof. A solution to this is the integration of Photovoltaic and Solar thermal systems in facades.

The RenoZEB project aims to unlock the nZEB renovation market through a new systematic approach to retrofitting. Among other activities, a "plug and play" modular façade construction system has been designed for the renovation of existing residential buildings towards NZEB performance. The "Plug and play" system has been developed to include and respond to all problems identified above.

Transitioning from research & development to implementation in commercial projects tends to take significant time and may imply undertaking considerable risks. To minimize these risks and accelerate the escalation of RenoZEB to ready-to-use innovative façade solutions the RenoZEB project includes a pre-validation phase. For this purpose, a full-scale system validation has been conducted in the KUBIK by Tecnalia infrastructure in Bilbao, Spain presented in (Chica et al., 2011; Roberto Garay et al., 2015).

2. System Definition

The RenoZEB "plug and play" modular façade is unitized facade system that overlaps the existing building without removing its original envelope. The system performs the following functions: Addition of insulation, improvement of envelope airtightness, replacement of fenestration and the integration of solar systems and efficient HVAC systems.

2.1. RenoZEB system's fixing design

The definition of the structural system of existing buildings has a central part in the design of the facade solution. It is important to ensure that the building can support the load added to the building due to the retrofit. Each building should be studied to determine the load bearing capacity and connection points.

“Plug and play” modular façade construction system for building renovation to achieve nearly Zero Energy Building (nZEB)

Considering common restrictions, in most cases, the fastening system is connected to the building Skeleton (pillar-slabs) bearing structure, usually made of concrete material.

The "Plug and play" modular façade is suspended from the fixing systems previously installed in the building structure. The fixing design of the panels allows for the correction of possible irregularities in the support, and the final location of the support can be modified in two directions. With this solution, large areas of facade can be installed quickly and easily in a short period of time, reducing the final duration of the on-site operations of the renovation work.

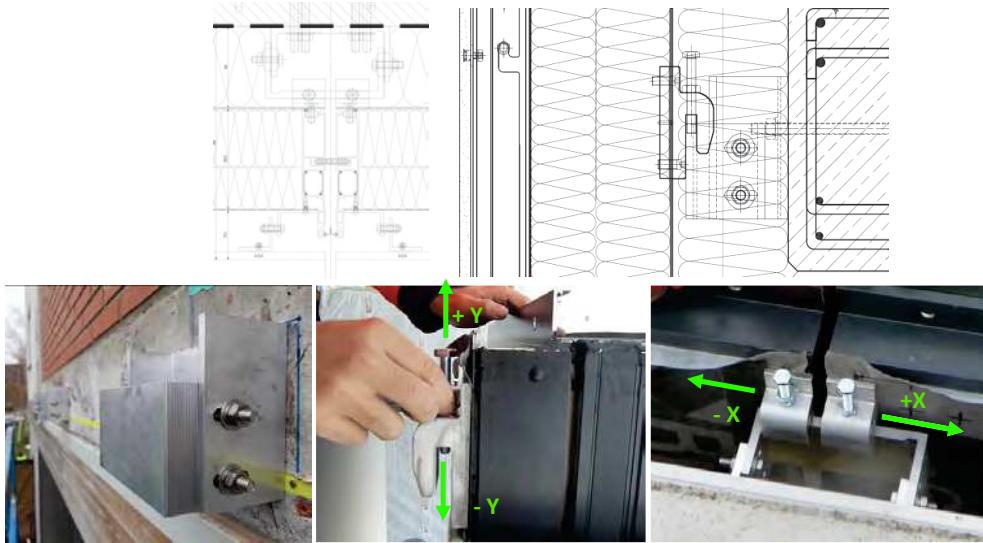

Figure 1: RenoZEB system's fixing design

2.2. Connection between panels

The panels are connected to each other by a single "plug and play" system, which connects them with two simple movements. The system of union between panels, besides facilitating its assembly guarantees the watertightness of the union.

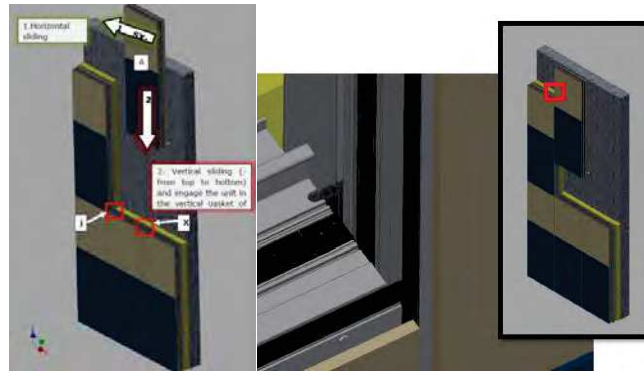

Figure 2: The RenoZEB system panel connection design

2.3. Wall composition

Once renovated, the building envelope is composed of three layers:

- ☐ Existing wall: This layer corresponds with the existing envelope of the building object of renovation. It is not necessary to be removed.
- ☐ Cavity: This layer is required to host the bracket that anchors the RenoZEB system and to absorb eventual tolerances of the existing wall. It is also designed to accommodate additional thermal insulation, if required.
- ☐ A prefabricated solution based on an aluminium frame anchored at the existing wall. This system incorporates thermal insulation, an external finish, Windows, or technical systems such as solar systems, or HVAC components.

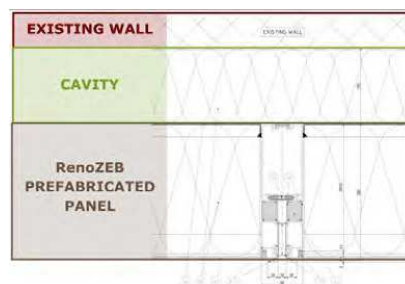

Figure 3: RenoZEB envelope system's wall composition (left) and Mock-up of the RenoZEB facade module (right)

The window frame unit can be adapted in size. The maximum height of the unit is 2500 mm and the maximum width of the unit is up to 2100 mm because of the maximum size of the façade modules. So, the system offers the possibility to get a wide range of different window openings.

“Plug and play” modular façade construction system for building renovation to achieve nearly Zero Energy Building (nZEB)

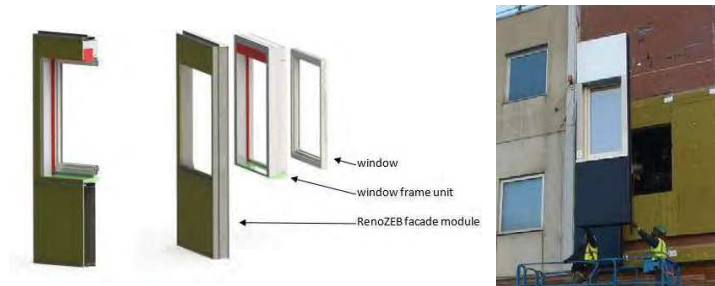

Figure 4: RenoZEB envelope vision unit cross section and parts

4. Early-stage full scale deployment

The RenoZEB “Plug and Play” module has been tested at full scale in KUBIK_{by} Tecnalia test facility, a full scale experimental infrastructure for R&D+I on energy efficiency and testing of building envelope systems. As some researchers (Garay et al., 2014; Garay et al., 2017; Garay et al., 2018) have pointed out, this building has already served as test environment for various building envelope retrofit systems. As Elguezabal et al. (2015) and Garay et al. (2016) have indicated, additionally to the thermal performance, it also allows to evaluate and develop the assembly and erection procedures, especially for industrialized solutions such as the RenoZEB “Plug and play” modular construction system.

The test setup has consisted on a two-floor façade section with an area of more than 20 m². Opaque panel units with windows have been used.



Figure 5: Installation of the RenoZEB Plug and Play façade system

Jorge Torres, Dr. Roberto Garay Martinez, J. Ignacio Torrens-Galdiz, Amaia Uriarte, Alessandro Pracucci, Oscar Casadei, Sara Magnani, Noemi Arroyo, Angel M. Cea

The time taken for installation was much less than that required for the installation of a conventional ventilated facade system and the auxiliary equipment needed is also less than that required for the installation of a conventional system. Only need a scissor lifts to access work area from externally and a Mobile crane/ Telescopic handler to lift the units during installation. For the installation is not necessary protection scaffolding. The total costs of the facade installation are reduced due to the saving of time and auxiliary equipment.

This test setup was used to validate critical points in the installation process. The full installation procedure was tested, including the installation of anchors in the façade, hanging of façade elements on them and sealing of junctions. A validation protocol was set so that the system proved to be adaptable to variations in anchor locations in 3D, allowed access for the assembly team to perform such adaptations and resulted in a satisfactory seal of junctions.

5. Retrofit of a real building

The renovation of a real building will be carried out in Durango (Spain). The building consists of a 3 Floor Residential building with 7 apartments, with an exempt rectangular floor plan (22m x 9m) and 12.00m in height, a gross area of 792 m² and net space conditioned area of 374 m². Originally built in 1960 with a reinforced concrete structure, the building was renovated in 2005. In its configuration prior to the renovation, façades consists of a cavity wall comprising, an outer hollow brick layer, 4 cm insulation, air chamber, an interior hollow brick layer and 3 cm plaster. The facades have an exterior finish of two types; a base and lateral finish of natural stone, combined with face brick.



Figure 6: Pictures of the building

The retrofit of the facade will span over 196 m² and is programed for initiation in October 2020. With triple target of 60% energy use and 80% CO₂ reduction, and providing 20% of renewable energy.

Along with the energy targets, the "plug and play" modular facade system is expected to perform large reductions in cladding materials (50%), insulation boards (20%) and construction waste (25%).

“Plug and play” modular façade construction system for building renovation to achieve nearly Zero Energy Building (nZEB)

The final design is the outcome of a parametric energy simulation process with the different intervention possibilities. Multiple combinations of retrofitting variants have been simulated, assessing the space heating and ventilation energy needs, and the intervention cost.

Its configuration comprises highly insulated opaque sections ($U= 0.2 \text{ W/m}^2\text{K}$) and windows ($U= 1,1 \text{ W/m}^2\text{K}$), as well as a large installation of solar thermal and PV panels in the South-exposed walls. The energy savings achieved are indicated in the following table:

Table 1: Results of energy simulations of retrofit

	PRE Retrofit (kWh/m ²)	POST Retrofit (kWh/m ²)
Space heating energy demand	110	14.5
DHW demand	19	19
SH+SH energy use	180	33



Figure 7: Left: Current stage building drawings in REVIT based on building’s 3D scanning. Right: retrofitting proposal, modules lay out

Previous construction works at KUBIK validated that the fixing system was reliable and replicable, as well as the quality of module-to-module junctions.

This system works perfectly for the renovation of buildings with flat roofs, and for all floors of a building with a sloping roof except for the top floor. Due to the typology of the roof, the vertical displacement of the panel for its fixation on the façade is not possible.

This is actually the configuration of the wall-to-roof junction in Durango. It comprises a relevant protrusion which has posed a significant challenge for the definition of the installation works.

For this reason, a system has been designed to hang the panel so that it can be fixed to the façade, avoiding the roof eaves. A specific connection detail and tooling design has been required for this case. Because the "Plug and Play" modular façade is not fixed to the structure and the panels are suspended from the fixing systems previously installed in the building structure. For this reason, they must be installed by moving them vertically on the building's façade as shown in the following image. As it can be seen, it has been necessary to modify the system of hanging the panels in order to be able to carry out the installation.

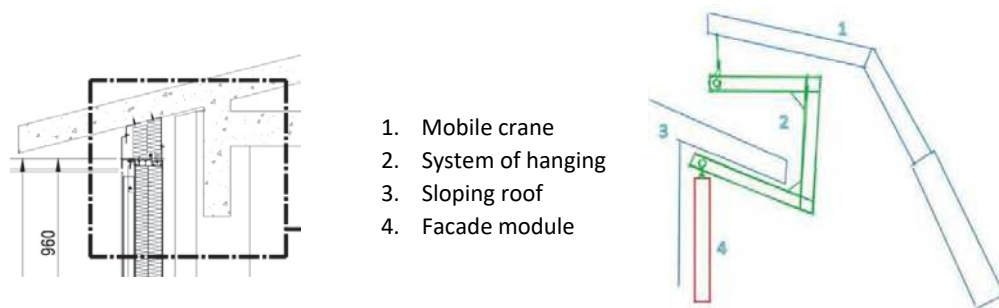

Figure 8: fixing system meeting with sloping roof

This system will be replicable for any other building with this type of roof, allowing the use of the plug and play system designed for all existing building typologies.

6. Discussion & Conclusions

The RenoZEB project, responds to the need for renovation packages that facilitate the improvement of the building fabric, incorporating insulation, providing air-tightening and allowing integration of building services and solar technologies. The developed facade system allows in a simple and fast way to carry out the renovation of an existing building allowing the and achieving near zero energy consumption buildings (nZEB) reducing the final duration of the on-site operations of the renovation work.

“Plug and play” modular façade construction system for building renovation to achieve nearly Zero Energy Building (nZEB)

The design, construction, manufacture & installation cycle, and the solution of anchoring and fixing of the modular "plug and play" facade system has been tested, and it has been verified that the execution times and auxiliary equipment needed are reduced compared to the execution of a conventional ventilated façade.

The implementation of the “plug and play” modular facade system at full-scale in KUBIK has served to validate the system under controlled conditions and remove uncertainty from the escalation process.

The fixation system developed for the system allows for adaptation to the common irregularities in existing walls, so that the Plug and Play system can be applied under real conditions. However, the authors’ acknowledge that a proper structural analysis of the existing wall needs to be performed so that its load bearing capacity is guaranteed and it is necessary to resolve how the modular facade system are integrated in the building’s system, considering all the adjacent elements, such as wall-to-roofjunction.

In the retrofit of a real building, it has been necessary to modify the system of hanging the panels in order to be able to carry out the installation because the sloping roof prevented the vertical displacement of the panel for its fixation on the façade, which has posed a significant challenge for the definition of a system to hang the panels, but will be replicable for any other building with this type of roof.

Acknowledgements

This project has received funding from the European Union’s Horizon 2020 research and innovation programme under grant agreement No 768718.

References

- Chica, JA et al, (2011), *KUBIK: Open building approach for the construction of an unique experimental facility aimed to improve energy efficiency in buildings*. Proceedings of the O&SB2010 “Open and Sustainable Building”, ISBN: 978-84-88734-06-8
- Council Directive 2002/91/EC on the Energy Performance of Buildings. EPDB.
- Council Directive 2010/31/EU, on the Energy Performance of Buildings. EPDB (recast).
- Council Regulation (E.U.) No. 305/2011 *laying down harmonised conditions for the marketing of construction products*. CPR.
- Economidou, M., Atanasiu, B., Despret, C., Maio, J., Nolte, I., & Rapf, O. (2011). *Europe’s buildings under the microscope. A country-by-country review of the energy performance of buildings*. Buildings Performance Institute Europe (BPIE).
- Elguezabal Esnarrizaga, Peru; Garay Martinez, Roberto. (2015), *Experiences When Employing Different Alternatives For Envelope Upgrading*, Journal Of Facade Design And Engineering, V. 3, N. 1, P. 81-89,. ISSN 2213-3038. <<https://doi.org/10.7480/jfde.2015.1.921>>.
- EU, JRC, *Comprehensive study of building energy renovation activities and the uptake of nearly zero-energy buildings in the EU Final report*, <https://ec.europa.eu/energy/sites/ener/files/documents/1.final_report.pdf>.
- Garay Martinez, Roberto, (2018), *Hybrid numerical and experimental performance assessment of structural thermal bridge retrofits*, Journal of Facade Design and Engineering, v. 6, n. 2, p. 095-106,. ISSN 2213-3038. <<https://doi.org/10.7480/jfde.2018.2.2206>>.
- L. Pérez-Lombard, et al., (2008). *A review on buildings energy consumption information*, Energy Build. 40
- Ravetz, J. (2008), *State of the stock – What do we know about existing buildings and their future prospects?* Energy Policy, 36(12), 4462-4470.

Jorge Torres, Dr. Roberto Garay Martinez, J. Ignacio Torrens-Galdiz, Amaia Uriarte, Alessandro Pracucci, Oscar Casadei, Sara Magnani, Noemi Arroyo, Angel M. Cea

- Roberto Garay Martinez, Josu Benito Ayucar, Beñat Arregi Goikolea, (2017), *Full scale experimental performance assessment of a prefabricated timber panel for the energy retrofitting of multi-rise buildings*, Energy Procedia, Volume 122, 2017, Pages 3-8, ISSN 1876-6102, <<https://doi.org/10.1016/j.egypro.2017.07.288>>.
- Roberto Garay, Amaia Uriarte, Inés Apraiz, (2014), *Performance assessment of thermal bridge elements into a full scale experimental study of a building façade*, Energy and Buildings, Volume 85, Pages 579-591, ISSN 0378-7788, <<https://doi.org/10.1016/j.enbuild.2014.09.024>>.
- Roberto Garay, Beñat Arregi, Peru Elguezabal, (2016), *Experimental Thermal Performance Assessment of a Prefabricated External Insulation System for Building Retrofitting*, Procedia Environmental Sciences, Volume 38, 2017, Pages 155-161, ISSN 1878-0296, <<https://doi.org/10.1016/j.proenv.2017.03.097>>.
- Roberto Garay, José Antonio Chica, Inés Apraiz, José M. Campos, Borja Tellado, Amaia Uriarte, Víctor Sanchez, (2015), *Energy efficiency achievements in 5 years through experimental research in KUBIK*, Energy Procedia, Volume 78, Pages 3222-3227, ISSN 865-870, <<https://doi.org/10.1016/j.egypro.2015.11.009>>
- United Nations Environment Programme (2015)– *Sustainable Buildings and Climate Initiative*, Retrieved March 30, from <<http://www.unep.org/sbci/AboutSBCI/Background.asp>>
- Web (1979), *NBE CT-79 Norma Básica de la Edificación* <<https://www.boe.es/buscar/doc.php?id=BOE-A-1979-24866>>
- Web (2019), *CTE 2019* <<https://www.codigotecnico.org/DocumentosCTE/DocumentosCTE.html>>