



Università  
degli Studi  
di Ferrara

DA Dipartimento  
Architettura  
Ferrara



A typological approach contribution  
to risk analysis:  
a GIS system based on widespread seismic  
damage for cemetery type

Candidate: Veronica Vona  
DA Supervisor: Arch. Marco Zuppioli  
POLIS Supervisor: Arch. Dorina Papa

External Expert: Arch. Antonino Libro

Cycle XXXIV

IDAUP



Università  
degli Studi  
di Ferrara

IUSS

International Doctorate in Architecture and Urban Planning





**Università  
degli Studi  
di Ferrara**

**DA** Dipartimento  
Architettura  
Ferrara



## **INTERNATIONAL DOCTORATE IN ARCHITECTURE AND URBAN PLANNING**

**Cycle XXXIV**

**IDAUP Coordinator Prof. Roberto Di Giulio**

### **A typological approach contribution to risk analysis: a GIS system based on widespread seismic damage for cemetery type**

**Curriculum** Architecture / IDAUP Topic 1.5 - Cultural heritages. Innovations and ICT processes  
for cultural heritages use and conservation  
(Area 08 – SSD: ICAR/19 Restoration)

**Candidate**

Veronica, VONA

**Supervisor DA**

Marco, ZUPPIROLI

(UniFe Matr. N. 068260)

(Polis Univ. Reg. N.PL581N080006)

**Supervisor POLIS**

Dorina, PAPA

**External Expert**

Arch. Antonino LIBRO

(Years 2018/2022)





Università  
degli Studi  
di Ferrara

Sezioni

## Dottorati di ricerca

Il tuo indirizzo e-mail

vnovnc@unife.it

Oggetto:

Dichiarazione di conformità della tesi di Dottorato

Io sottoscritto Dott. (Cognome e Nome)

Vona Veronica

Nato a:

Urbino

Provincia:

Pesaro-Urbino

Il giorno:

27/04/1985

Avendo frequentato il Dottorato di Ricerca in:

ARCHITETTURA E PIANIFICAZIONE URBANA

Ciclo di Dottorato

34

Titolo della tesi:

A typological approach contribution to risk analysis: a GIS system based on widespread seismic damage for cemetery type

Titolo della tesi (traduzione):

Un contributo di approccio tipologico all'analisi del rischio: un sistema GIS basato sul danno sismico diffuso per il tipo cimiteriale

Tutore: Prof. (Cognome e Nome)

Marco Zuppiroli

Settore Scientifico Disciplinare (S.S.D.)

ICAR/19

Parole chiave della tesi (max 10):

rischio sismico, schede del danno, analisi di vulnerabilità, analisi tipologica, rilievo sul campo, seismic hazard, damage survey form, vulnerability assessment, type interpreting, on-site survey

Consapevole, dichiara

CONSAPEVOLE: (1) del fatto che in caso di dichiarazioni mendaci, oltre alle sanzioni previste dal codice penale e dalle Leggi speciali per l'ipotesi di falsità in atti ed uso di atti falsi, decade fin dall'inizio e senza necessità di alcuna formalità dai benefici conseguenti al provvedimento emanato sulla base di tali dichiarazioni; (2) dell'obbligo per l'Università di provvedere al deposito di legge delle tesi di dottorato al fine di assicurarne la conservazione e la consultabilità da parte di terzi; (3) della procedura adottata dall'Università di Ferrara ove si richiede che la tesi sia consegnata dal dottorando in 1 originale cartaceo e 1 in formato PDF/A caricata sulla procedura informatica Esse3 secondo le istruzioni pubblicate sul sito: <http://www.unife.it/studenti/dottorato> alla voce ESAME FINALE – disposizioni e modulistica; (4) del fatto che l'Università, sulla base dei dati forniti, archiverà e renderà consultabile in rete il testo completo della tesi di dottorato di cui alla presente dichiarazione attraverso la pubblicazione ad accesso aperto nell'Archivio Istituzionale dei Prodotti della Ricerca IRIS-UNIFE ([www.iris.unife.it](http://www.iris.unife.it)) oltre che attraverso i

Cataloghi delle Biblioteche Nazionali Centrali di Roma e Firenze; DICHIARO SOTTO LA MIA RESPONSABILITÀ: (1) che la copia della tesi depositata presso l'Università di Ferrara in formato cartaceo è del tutto identica a quella caricata in formato PDF/A sulla procedura informatica Esse3, a quelle da inviare ai Commissari di esame finale e alla copia che produrrò in seduta d'esame finale. Di conseguenza va esclusa qualsiasi responsabilità dell'Ateneo stesso per quanto riguarda eventuali errori, imprecisioni o omissioni nei contenuti della tesi; (2) di prendere atto che la tesi in formato cartaceo è l'unica alla quale farà riferimento l'Università per rilasciare, a mia richiesta, la dichiarazione di conformità di eventuali copie; (3) che il contenuto e l'organizzazione della tesi è opera originale da me realizzata e non compromette in alcun modo i diritti di terzi, ivi compresi quelli relativi alla sicurezza dei dati personali; che pertanto l'Università è in ogni caso esente da responsabilità di qualsivoglia natura civile, amministrativa o penale e sarà da me tenuta indenne da qualsiasi richiesta o rivendicazione da parte di terzi; (4) che la tesi di dottorato non è il risultato di attività rientranti nella normativa sulla proprietà industriale, non è stata prodotta nell'ambito di progetti finanziati da soggetti pubblici o privati con vincoli alla divulgazione dei risultati, non è oggetto di eventuali registrazioni di tipo brevettale o di tutela. PER ACCETTAZIONE DI QUANTO SOPRA RIPORTATO

Dichiarazione per embargo

12 mesi

Richiesta motivata embargo

1. Tesi in corso di pubblicazione

Liberatoria consultazione dati Eprints

Consapevole del fatto che attraverso l'Archivio Istituzionale ad accesso aperto dei Prodotti della Ricerca IRIS-UNIFE ([www.iris.unife.it](http://www.iris.unife.it)) saranno comunque accessibili i metadati relativi alla tesi (titolo, autore, abstract, ecc.)

Firma del dottorando

Ferrara, li 15/06/2022(data) Firma del Dottorando Veronica Vona

Firma del Tutore

Visto: Il Tutore Si approva Firma del Tutore Marco Zuppiroli

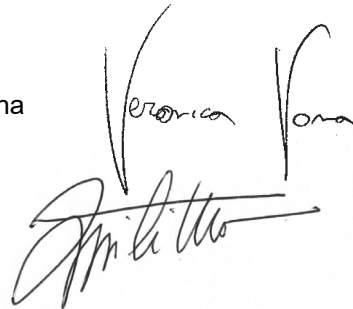
The image shows two handwritten signatures in black ink. The top signature is 'Veronica Vona' and the bottom signature is 'Marco Zuppiroli'. The signatures are written in a cursive, flowing style.

## Acknowledgements

At the conclusion of this experience, which marks the conclusion of a chapter in my life, that of the PhD, I would like to express my gratitude to several people who have supported me in various ways.

My first word of thanks goes to Prof. Dalla Negra, Supervisor of this thesis for more than two years. However, it would be reductive to summarize with these words his contribution in my growth and education, and therefore I want to be grateful to him for the theoretical and practical teachings that in the last 10 years spent within LaboRA have allowed me to grow and acquire experiences and awareness.

I would like to extend my thanks to arch. Marco Zuppiroli, who over the years always foresaw, even before I figured it out, what directions I would take: a thanks for first teaching me, way back in 2013, about GIS; a thanks for identifying the University of Minho as a place to further my research before it was even clear to me what I wanted to explore; and finally a thanks for also being my first experimenter of the form on one of the coldest days of the year...with a malfunctioning car heater.

Moreover, a due thank goes to arch. Libro, a reference point for understanding the management of the 2012 earthquake, whose reviews with surgical precision identified every possible in-depth study, and to the entire Regional Agency for Reconstruction - Earthquake 2012, which not only financed this research but also hosted me in its offices and supported me in finding the materials needed for the thesis.

I also extend my thanks to Arch. Javier Ortega, whose enthusiasm allowed me to achieve a goal for my thesis that was unthinkable before his input.

A special thanks then goes to Andrea Valerio Canale, Luca Cei, Luca Formigari, Riccardo Crescentini, Davide Felici, Enrico Montalti, Alessandro Negro, Matteo Piscicelli, Daniele Romagnoli, Alessandra Santilli, Giorgio Tangherlini, Stefano Tessarolo, Siegfried Vona and Marta Zannotti for their indispensable contribution in testing the cemetery form on cold January days, and to the support network of friends who from Padua to Grottaglie always made themselves present: Angela, Federica, Gige, Lorenzo Martina and Riccardo.

Finally, I thank my family, who were always willing to help me, and put up with me whenever things seemed too difficult, and Daniela, who so patiently acted as my "English consultant" during these three years.





## Abstract

In Italy the *Guidelines for the evaluation and reduction of seismic risk on Cultural Heritage*, and the Directive 12/12/2013 “*Procedures for management of activities for cultural heritage securing and safeguarding in the event of emergencies caused by natural disasters*” identify the compilation of forms to provide vulnerability and damage level representation on movable and immovable assets as an initial procedure. In particular, they establish two important survey instruments: the A-DC Churches and the B-DP Stately Buildings forms.

These are the only two instruments used between 2012 and 2013 for the damage level characterization of the cultural heritage caused by the “Emilia 2012” earthquake. The widespread use of these forms has brought to light several problems that have negatively affected the successive economic assessment of the intervention. In fact, if these sheets describe the vulnerabilities of the specialized types, such as Churches or Stately Buildings well, they are simultaneously ill suited to types with different features, which, in the Emilia-Romagna case, represent about 30% of damage to cultural heritage numerically and economically. In particular, a significant sample of these types is the cemetery type with more than 100 buildings damaged, a percentage equal to 70% of the entire complex of cemeteries located within the crater area.

Accordingly, the aim of this research is to analyse the damage suffered by this type so as to improve the damage assessment procedures, both in the emergency phase and in terms of seismic risk mitigation. The main purpose is to address the cultural heritage restoration policies towards more technically and economically sustainable actions.

Therefore, based on the data collected for the cemeteries damaged in the “Emilia 2012” earthquake, the cemetery type was investigated according to its several aspects: historic and architectural, economic, level of damage, and finally vulnerability. Each of these aspects provided the framework for the definition of a new first-level tool that could be both a damage survey tool and a proactive vulnerability assessment tool. Indeed, the complete compilation of the tool provides an estimate of the damage index and the related repair cost. The partial compilation, on the contrary, allows for the identification of the parameters for the definition of a vulnerability index correlated with a vulnerability curve specifically defined for cemeteries. In the first case it is possible to use the tool in the immediate and urgent phases of the emergency to determine the material and economic impact of the earthquake on the assets; in the second case, instead, it is possible to address the policies of seismic risk mitigation through vulnerability analyses at a territorial scale.

Finally, its status of land-management tool has resulted in its development on a GIS-based digital format for its integration within the regional technical cartography and for the on-site survey.

More than a final solution to the issue of damage assessment in cemeteries, however, this study on cemetery type should be considered as a first step towards the optimization of damage assessment procedures for building types other than churches and Stately Buildings. Only after a seismic event may the new form application provide the feedback on its effective use in emergencies and lead towards its progressive refinement.



## **Abbreviations**

<b>AeDES</b>	Model for damage survey, emergency response and practicability for basic buildings in the post-seismic emergency
<b>Agency</b>	Regional Agency for Reconstruction - Sisma 2012
<b>A-DC form</b>	MODEL A-DC Churches
<b>B-DP form</b>	MODEL B-DP Stately Building
<b>CCS</b>	Aid Coordination Centers
<b>CLE</b>	Emergency Limit Condition
<b>COC</b>	Municipal Operational Centers
<b>COM</b>	Mixed Operational Centers
<b>CNR</b>	National Research Council
<b>CTR</b>	Regional Technical Map
<b>Di.Coma.C</b>	Direction of Command and Control-National Coordination Center of the Civil Protection Components and Operational Structures
<b>DPC</b>	Department of Civil Protection
<b>DURER</b>	Unique Database of Reconstruction of the Emilia-Romagna Region
<b>FENICE</b>	Funding to public agencies for building reconstruction interventions
<b>GIS</b>	Geographic Information System
<b>GLABEC</b>	Working Group for the Prevention of Cultural heritage from Natural Hazards
<b>GNDT</b>	National Earthquake Defence Group
<b>GV</b>	Validation Group
<b>ICCD</b>	Central Institute for Catalogue and Documentation
<b>INGV</b>	National Institute of Geophysics and Volcanology
<b>MiC</b>	Ministry of Culture

<b>SFINGE</b>	Grants and facilitated financing to enterprises
<b>OOPP and BBCC</b>	public buildings and cultural heritage
<b>RAN-DPC</b>	National Accelerometric Network of the Civil Protection Department
<b>ReLUIS</b>	Network of Earthquake Engineering University Laboratories
<b>RU</b>	Research Unit
<b>UCCR</b>	Crisis Unit - Regional Coordination Mibac
<b>VE</b>	Economic Evaluation

# Index

## CHAPTER 1 - Introduction

1.1	Introduction	3
1.2	Development in Italy of quick-survey tools for seismic damage and vulnerability	5
1.3	Current operating tools for damage and vulnerability assessment	28
1.4	Timelines for First-Level forms	64
1.5	First-level forms and vulnerability	67

## CHAPTER 2 - The “Emilia” earthquake

2.1	The “Emilia” earthquake	73
2.2	From emergency management to reconstruction management	74
	• The first emergency and the DPC activities	74
	• The Deputy Commissioner activity and the reconstruction process	77
2.3	Knowledge capital for resilience. The Cultural Heritage between damage survey and cost of intervention: identification of investigation set and methodology	81
	• Introduction	816
	• The Cultural Heritage survey: from operative problems to the databases implementation, resolution of organizational criticalities	82
	• The Cultural Heritage survey: not solved criticalities	85
	• Aim and Object of Study Identification: Damaged Types and Selection Criteria	86
	• Methodology	91

## CHAPTER 3 - Type interpreting: the cemetery type

3.1	General framework for the typological interpretation of cemeteries	95
3.2	Historical and architectural framework	98
3.3	Cemetery typological interpreting	105
	• Cemeteries and urban morphology	105
	• Determining the matrices of specialization: interpreting the typological series	107
3.4	The features of cemeteries in the Emilia-Romagna earthquake crater	123
	• Morpho-typological feature	123
	• Main technological and constructive features	126
3.5	From typological interpretation to the definition of the macro elements of the cemetery organism	133
	• Introduction and meaning of macro-element	133
	• Enclosure wall macro-element	134

• Crossing element macro-element	135
• Columbarium macro-element	135
• Family tomb macro-element	135
• Funeral chapel macro-element	135
CHAPTER 4 - Damage analysis	
4.1. Introduction: motivation, type of data, their consistency and analysis	139
4.2. Digitisation of forms: first GIS database setup	142
4.3. Analysis of alphanumeric data: identification of weaknesses and macro-element check	145
4.4. Analysis of photographic data and identification of collapse mechanisms	158
• Surrounding wall mechanisms	158
• Crossing element mechanisms	160
• Columbaria mechanisms	166
• Funerary chapel mechanisms	174
• Definition of recurring collapse mechanisms	175
4.5. From repair cost to parametric cost for resource allocation	180
CHAPTER 5 - Cemeteries vulnerability: first reflections	
5.1 Introduction	187
5.2 Protocol samples for the vulnerability assessment of historic buildings based on the Vulnerability Index (Iv)	190
• Introduction	190
• Italian and foreign samples of operational protocols: formulation and application context	191
• Criticality of the application of existing methods to cemetery type	197
5.3 Study and identification of potential parameters for defining a vulnerability protocol for cemetery type	198
• Identification of potentially relevant parameters	198
• Identification of the operational protocol for the vulnerability index assessment	203
• Correlation of the index application method to the macro-seismic method: definition of a vulnerability curve for cemeteries	207
5.4 Critical discussion of the data obtained	211
CHAPTER 6 - Setting up of a new form for historical cemeteries	
6.1 Introduction	215
6.2 Technical choices and for criticality overcoming	216
• Media Format choice	216
• Critical-operational choice	220

---

6.3	Form structure of the first draft experimented	222
	• Data preserved by existing tools	223
	• Tabs for first-level vulnerability assessment	224
	• Tabs for first-level damage survey	226
	• Form Digitalization	228
CHAPTER 7 - Experimentations		
7.1	Introduction	233
7.1	Experimentation on-desk: Concordia sulla Secchia cemetery – Emilia-Romagna damaged cemetery, economical assessment validation	234
	• Brief description	234
	• Data collected	236
	• Fulfilment of the new cemeteries form: damage index definition	237
	• Economical validation thorough the new form	241
7.2	On-site experimentation: Second draft setting up	243
	• Aim of the experimentation and identification of the test group characteristics	243
	• Cemeteries surveyed	245
	• Analysis of the results	249
	• Revision of first set up: The new form for the cemetery type	252
7.3	Form for cemetery type	255
7.4	On-site survey optimization: Survey123 vs Qfield	273
	• Introduction	273
	• Survey123	274
	• Qfield	282
	• Conclusion	287
CHAPTER 8 - Conclusion		
8.1	Summary of the present work	291
8.2	Future developments	293
REFERENCES		
R.1	Bibliografy	299
R.2	Webliography - essential websites	311
ANNEXES		
		313





# CHAPTER 1

## Introduction

1. RIBALTAMENTO DELLA FACCIATA

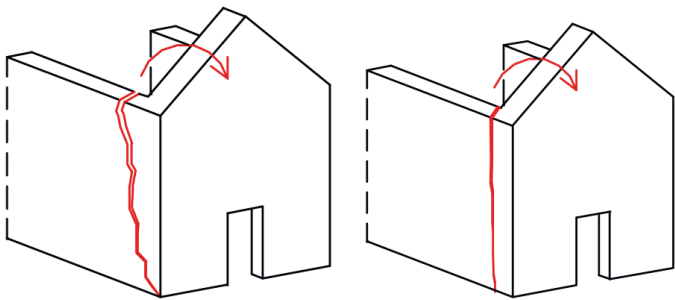

2. MECCANISMI NELLA SOMMITÀ DELLA FACCIATA

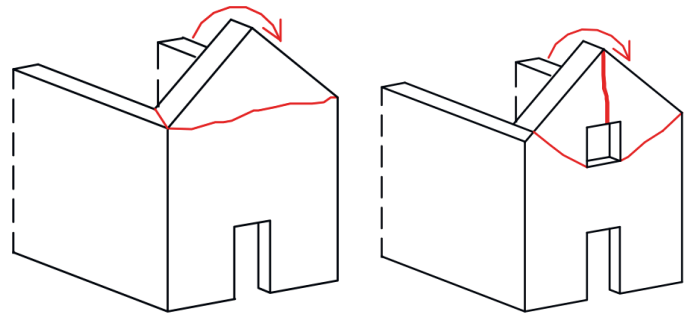

3. MECCANISMI NEL PIANO DELLA FACCIATA

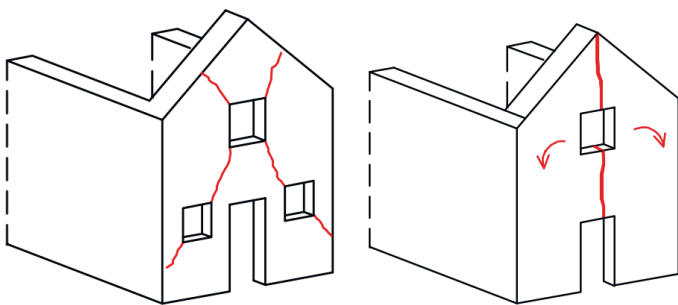

4. RISPOSTA TRASVERSALE DI AULA O TRANSETTO

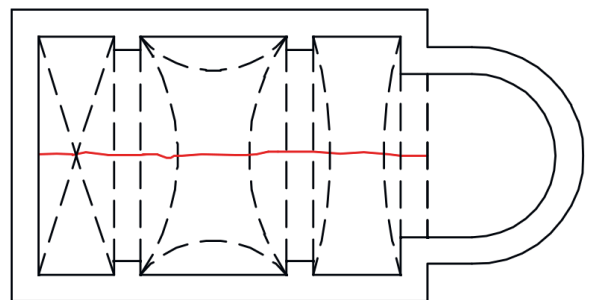

5. RISPOSTA LONGITUDINALE NAVATA CENTRALE

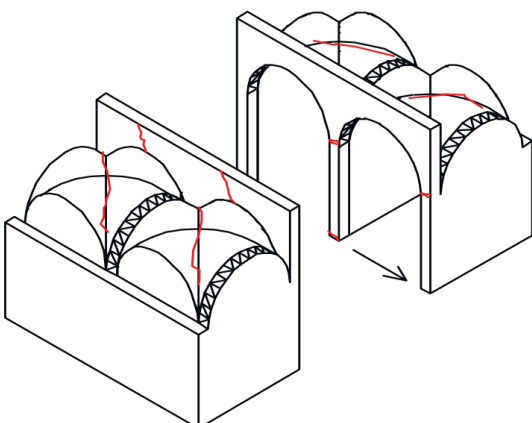

6. VOLTE DELLA NAVATA CENTRALE

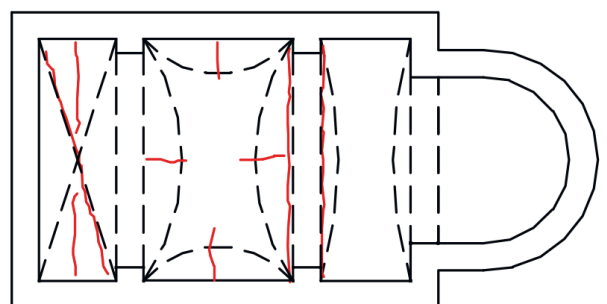

On the previous page an extract from the collapse mechanisms studied for churches and published in 2001 (Presidenza del Consiglio dei Ministri, 2001).

## 1.1 Introduction

“[...] the building that becomes the subject of our restoration project must be understood in its architectural “reality”, which is not only material, figurative or structural, it is an organic reality where the components cannot be separated from each other” (Dalla Negra, 2015). Today, thinking of the restoration project as the project that translates requests coming from multiple research fields into an organic product rooted in the understanding of the intervention subject, seems natural and innate to the concept of Architectural Restoration itself. Nevertheless, the relationship between form and structure, and consequently between the “*imaginative and artistic architect*” and the simple “*structural engineer*” (Fancelli, 2003) has often been a topic of debates and misunderstandings both in Academies and in professional practice.

Despite this, the structure is a vital component of historical architecture which must be both investigated and transmitted to future generations, along with every other aspect. It is the vehicle of experience and values, of constructive knowledge that is part of the “*text*” whose transmission should be the restoration subject. Moreover, looking at the issue of seismic vulnerability, the image of Pirro Ligorio’s anti-seismic house, or Vincenzo Ferraresi’s Baraccata house (Fig. 1), were not they also the product of the structure and the mechanical principles that supported them?

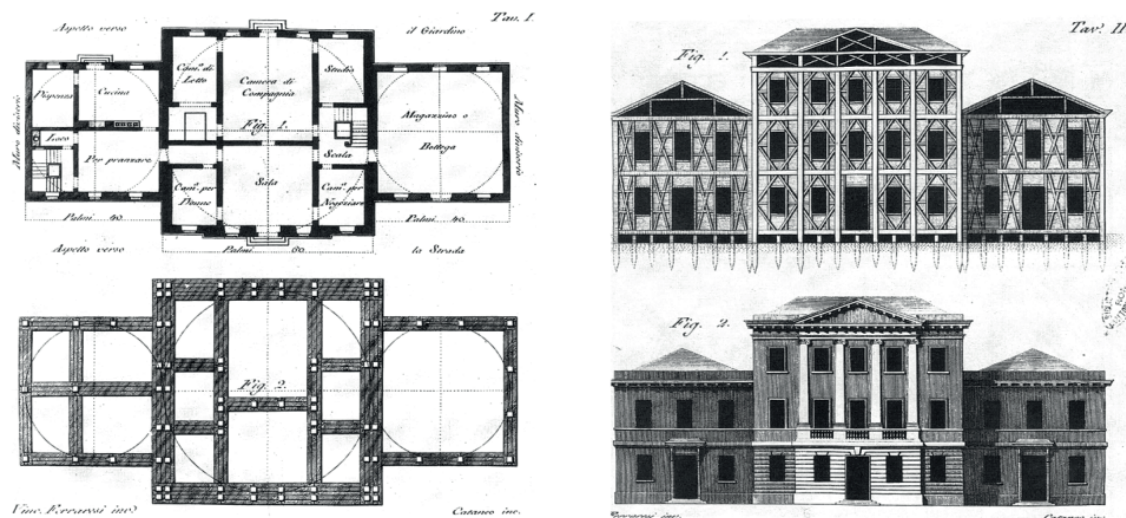

Fig.1. Pland and Section by Vincenzo Ferraresi in “La casa-tipo. Proposte tecniche”, 1783. Excerpts of Vivenzio, 1783.

However, it is precisely when facing exceptional events, such as earthquakes, that the structure of the *formed form*<sup>1</sup>, which is the restoration subject, becomes the cause of the partial or complete loss of this “*text*”. Indissolubly linked to empirical knowledge and observation of natural phenomena, ancient building expertise has sometimes turned into a solution and sometimes into a cause. Thus, the rules of good practice in building have taken into account all the measures needed to prevent a structure from being damaged by natural phenomena

.....  
<sup>1</sup> Here we borrow a term from Pareyson (Pareyson, 1955). It is very often used in the disciplinary debate on aesthetics, restoration and the relationship between ancient and new.

when they have occurred in short distances. At the same time they have forgotten them as quickly as people culturally forget a traumatic event after a long time period<sup>2</sup>.

Without going too far back in time, the building regulations adopted at the beginning of the twentieth century after the catastrophic earthquakes that struck Italy (Calabria in 1905, Messina and Reggio in 1909 and Marsica in 1915) are reasonably attributable to this. This attitude is also the reason for the poor construction quality in the emilian area (Borri et al., 2013). It was an area that had not suffered for 400 years such a major earthquake as that which struck it in 2012.

Today it cannot be denied that the analysis of history of the structure's mechanics, and in particular that of masonry, "*of enduring prejudices, ingenious solutions as well as disconcerting conditioning*"(Bussi, 2003), underlies the restoration project<sup>3</sup>, as much as the study of the history of architecture and figurative aspects. It is thus not by chance that, precisely when image and structure are disjoined, human action creates further damage to already compromised architecture, especially in the emergency phase (Fig. 2). The L'Aquila earthquake exemplifies this (Bartolomucci, 2013).

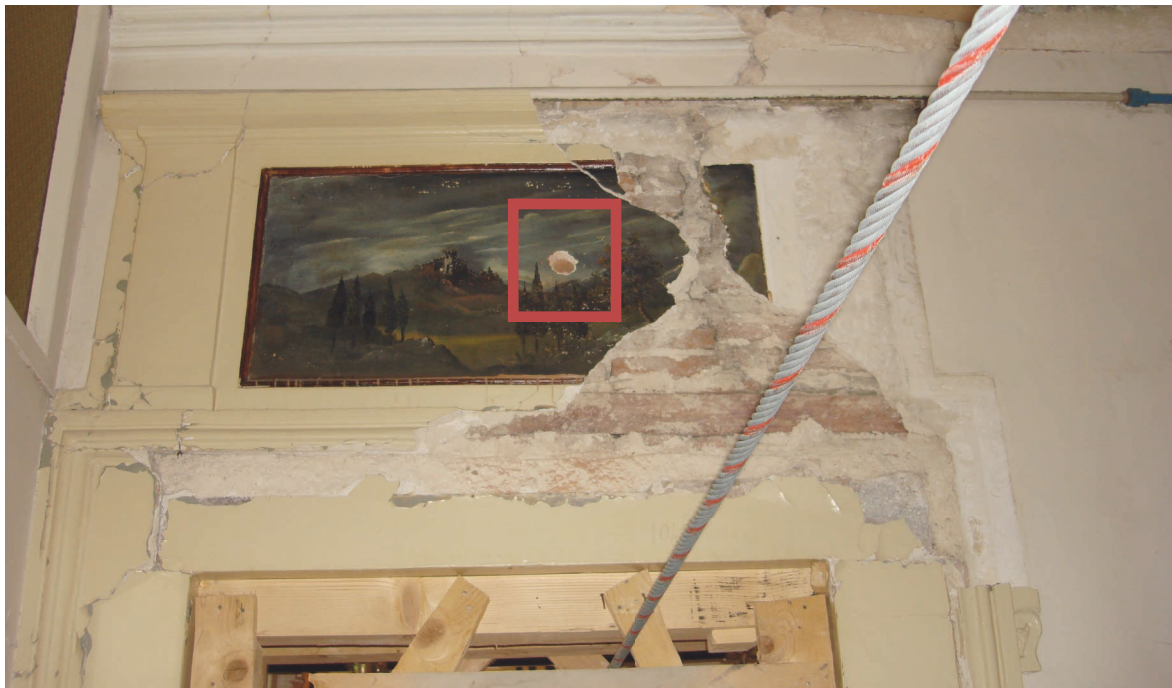

Fig.2. Palazzo Carli-Benedetti, L'Aquila. Marked in red, the damage caused to the wall paintings by the safety measures taken during the emergency phase. In order to secure the incipient overturning of the façade, tie rods were inserted without considering the figurative value of the rooms.

Therefore, the knowledge and understanding of the vulnerabilities intrinsic to our historical structures can only be considered an integral part of that knowledge, the completeness of which allows for a restoration project truly respectful of the building's history and values. In this case we refer to the restoration project as that project with purely conservative purposes which qualifies as "*an intervention in favour of the pre-existence*"(Dalla Negra, 2017b), able to make the architectural "*text*" still readable when it becomes incomplete (Dalla Negra et al., 2009; Dalla Negra, 2017b; 2019), often due to the earthquake.

.....

2 This is fertile ground for that branch of anthropology known as the anthropology of disasters.

3 It is understood as restoration and consolidation project.

The Italian legislation itself (Ministero delle Infrastrutture e dei Trasporti, 2008; Ministero per i Beni e le Attività Culturali, 2006), now aware of the impossibility of overcoming the uncertainty in assessing the historic building's performance, consigned the intervention's calibration to the level of knowledge of the building, especially if aimed at seismic improvement. The Confidence Factors (CF), with which we must operate now, decrease as the Levels of Knowledge (LC) achieved increase. This is not intended to be an aggravating element in the already long restoration process, but must be understood as a progressive process that, starting from the analysis of the most evident vulnerabilities, a level 1 of knowledge, proceeds towards an increasingly exhaustive understanding of the building. The aim therefore is to learn in order to reduce and improve the impact of our actions on the built environment.

Therefore, especially after a traumatic event such as an earthquake, a good restoration project does not begin when the task is assigned, but even before. It begins when its real damage state and its vulnerabilities are first identified, assessed, and safeguarded so that form and structure can be transmitted into the future. It therefore begins with the analysis of the damage survey and safety measures.

## **1.2 Development in Italy of quick-survey tools for seismic damage and vulnerability**

The current operating tools for cultural heritage used after seismic events are the result of a long development concerning not only the tools for the cultural heritage itself, but for the whole Italian built environment and it is necessarily linked to progress in the field of vulnerability and its survey. In order to understand changes, revisions and developments concerning the damage survey of Cultural heritage, it is necessary to have a broader framework that also takes into account the studies on survey tools for basic buildings, and on vulnerability.

From a temporal point of view, although - in line with the international debate - seismic vulnerability studies mainly geared towards probabilistic-predictive purposes were carried out in Italy even before 1980, the Irpinia earthquake triggered a new phase in the national vulnerability debate that started to address the actual observed damage. Indeed, until the Friuli earthquake (1976) the data collected on the observed damage were derived from surveys performed with tools not tailored to acquire data on actual damage but were instead designed for other purposes. After the Irpinia earthquake, the "*Progetto Finalizzato Geodinamica*" (PFG), a project started in 1976 after the Friuli earthquake<sup>4</sup>, provided a first surveying instrument aimed at damage acquisition. About 36,000 buildings were surveyed for the first time with the purpose of acquiring their damage through an instrument specifically designed for this objective (Stucchi, 2020). A massive campaign that, from the operational point of view, has allowed the definition in Europe of damage probability matrices (DPM) and, from the theoretical point of view, has marked in Italy the launch of a database aimed at collecting data on the seismic behaviours of structures (Corsanego & Gavarini, 1993). As

.....

4 A CNR Five-year project, which coordinated and funded researches in the main fields as seismology, geology, volcanology, seismic engineering, etc. The project was operational from 1976 to 1981 when the National Group for Earthquake Defence was established and took its place.

a consequence, the opportunity to have such a wide catalogue of investigated objects at disposal provided a new stimulus to vulnerability studies that led new methodologies for the identification of vulnerability indices being introduced in Italy. This includes Braga's method (Braga et al., 1982), the one proposed by Gavarini and Angeletti (Gavarini & Angeletti, 1984) for reinforced concrete and the one studied by Benedetti and Petrini (Benedetti & Petrini, 1984) specifically for masonry constructions.

The development of diversified methodologies depended, and still depends, on how one addresses the vulnerability problem that, in general, can follow three methodological approaches. The first is an indirect or empirical approach and is based on statistical surveys using the observed vulnerability as a reference. It requires the identification of homogeneous typological classes of buildings and the study of the observed damage distribution on them in relation to different macro-seismic intensities<sup>5</sup>. The second is a mechanical or direct approach, therefore based on the analysis of the seismic response of a theoretical model of buildings that must necessarily be deeply studied in their material and structural characteristics. This method gathers the observed damage data for the results validation and calibration. On the other hand, the third method is called a hybrid approach because it combines both qualitative and quantitative data through different procedures. However, it should be noted that, although this is the prevalent classification, it is possible to evaluate the different methods under further profiles. Corsanego and Gavarini (1993) at the beginning of the '90s classified the main methods of vulnerability assessment developed in Italy in the '80s through four different parameters: the methodological approach (typological, mechanistic and hybrid methods), the type of measurement through which the indices were defined (quantitative and qualitative methods), the types of results obtained (direct, indirect or conventional methods) and the prevalent type of data (statistical, analytical or subjective methods). Even from the overview of the 10 main methods studied in a limited time frame (the 1980s) in a precise geographical context (Italy) (Fig. 3), it is possible to understand how complex and various the field of vulnerability studies can be today.

**Table I.** A scheme of methodologies.

Method	01	02	03	04	05	06	07	08	09	10	11	12
Line	ME	ME	HY	HY	HY	TY	ME	HY	ME	HY	ME	HY
Measure	QN	QN	QN	QN	QN	QN	QN	QN	QN	QL	QN	QN
Results	DI	DI	IN	CO	DI	DI	DI	IN	DI	CO	DI	IN
Source	AN	AN	ST	SU	AN	ST	AN	ST	AN	SU	AN	ST

Fig.3. Classification of main Italian methodologies about vulnerability in '80 (Corsanego & Gavarini, 1993)

The study of vulnerability assessment methods according to these three methodological lines led to the definition of operational approaches in data collection. In this framework, the activity of the newly formed National Earthquake Defence Group (GNDT - 1981) was of considerable importance due to its focus on the problem of the existing building even if, in the first phase, it was still of an ordinary nature and not of a monumental one. The activity of GNDT in these years was characterized by the development of operational protocols for the buildings survey based on the definition of the levels that correspond to similar

.....  
 5 The macro-seismic intensity represents the earthquake effects measure on humans, buildings and environment. Its value is attributable only after observation of the damage produced by an earthquake in a place.

analysis strategies to be applied case by case to structures. The data collection was initially closely related to the methodology to be applied. The first-level surveys were based on the first methodological approach outlined above: it was simpler and easier to apply to many buildings at a low cost. The second-level surveys, which were, and still are, a more in-depth investigation of individual buildings, were based on the third. Indeed, the statistical analysis of the first-level forms was expressly mentioned in the guideline for the forms' compilation developed in 1986 after two large-scale experimental campaigns of these instruments (Consiglio nazionale delle ricerche, Gruppo nazionale per la difesa dai terremoti, 1986). These were carried out by GNDT in collaboration with the local administrations: Emilia-Romagna first, and then Tuscany.

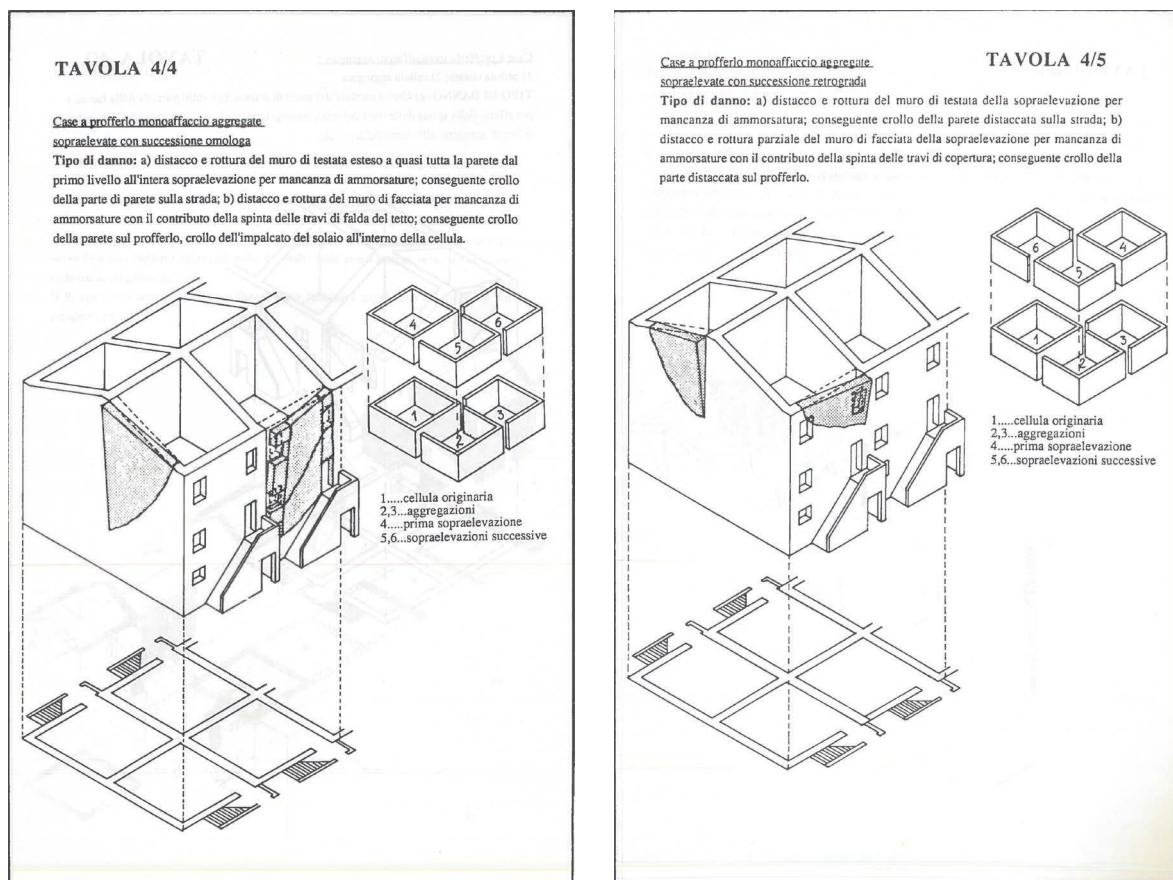

Fig.4. Use of typological analysis for the potential collapse mechanisms identification (Giuffrè, 1988)

It was the middle of the '80s when some researchers focused their attention on the Cultural heritage both as single emergencies and as a whole urban nucleus. Concerning this last issue, of great relevance were the studies of Antonino Giuffrè who studied the vulnerability of the ancient urban nuclei. He expressed it not in damage probability but in relation to the possible collapse mechanisms that could be activated (Giuffrè, 1988). Compared to previous and coeval studies, this one, although focused on urban centres, represents a study of particular value for monumental Cultural heritage. The in-depth study of historical masonry mechanics, carried out by Giuffrè<sup>6</sup>, demonstrated firstly the impossibility of evaluating historical buildings

.....  
<sup>6</sup> It is worth to mention that, besides Giuffrè, other scholars of Constructions Science, such as Benvenuto and Di Pasquale, investigated the problem of the historical constructions in masonry.

as elastic structures. Secondly, He showed how the damage to them was caused, before exceeding their resistance capacity<sup>7</sup>, by problems of equilibrium due to actions acting outside the plane (overturning of the structures or, generally, mechanisms of the first mode). Moreover, the research in Castelvetero sul Calore, led by Giuffrè, started from a typological analysis<sup>8</sup> and of the building techniques in order to “*identify a criterion to control the individual buildings safety, or at least to put them in a condition of safety with appropriate interventions*” (Giuffrè, 1988:9). The typological analysis represents in this case the first tool available to those who deal with historical buildings in order to forecast the potential building collapse mechanisms and the subsequent damage modes. Indeed, the knowledge of the building typologies of a place in a dynamic and developmental sense allows us to identify the most probable area in which the structure is lacking, such as in the masonry gripping or in the connections between roofing elements and vertical structures (Fig. 4).

As far as the single emergencies are concerned, one of the first experiences for the Monumental Heritage survey is the one carried out by A. Ceradini and other researchers in 1986. It is a catalographic campaign performed on a total of 60 monuments between Abruzzo, Marche and Umbria and required by the National Committee for the Prevention of Cultural Heritage from Seismic Risk<sup>9</sup> in order to identify the exposure level to seismic action of each site. To this purpose, the first proposal report determined the necessity to acquire three different orders of information: the seismic nature of the sites, the seismic vulnerability of the assets and their “value”. With regard to the second point, Ceradini surveyed 15 of the 60 properties, all placed in Abruzzo, by applying a seismic-structural form which was accompanied by the Form A prepared by the Central Institute of Catalogue (hereafter ICCD) for churches survey. This last form had to answer to the third question raised by the Committee: the identification of the “value”. The seismic-structural form, a 4-page sheet provided by the Committee, was not a tool designed for the survey of historical buildings belonging to periods after the Middle Ages. It had been realized for the survey of the Pompei conservation state and had been subsequently adapted to allow its application in other contexts (Fig. 5). Following the first experimentation, Ceradini (1987) explained in his subsequent report that the form was easy to compile for small-size buildings with low typological constructive variety but was not suitable for complex cases. He also highlighted the absence of a crucial record concerning the knowledge and identification of the main buildings’ constructive phases, which was fortunately provided by form A. This was of fundamental importance for understanding the building’s structure and therefore this data should be acquired.

Of particular interest for subsequent experimentation was the choice of attaching a graph (Fig. 6), not foreseen by the forms, which would show a scheme of the investigated building and a type of essential chronology of its seismic-structural history. The purpose of this

.....

7 It obviously refers to good quality masonry. In the case of bad quality, no mechanism can be activated because the damage is caused by the disaggregation of the masonry itself.

8 Study conducted by Professor Arch. Michele Zampilli on the basis of the Gianfranco Caniggia methodology for the investigation of historic centres.

9 It is a committee established in 1984 at the behest of the Ministry of Cultural and Environmental Heritage in coordination with the Minister for the Coordination of Civil Protection. It had among its main tasks the promotion of research aimed at seismic prevention, the promotion of the systematic data collection on Cultural heritage and the drafting, within the current regulatory framework, of further specific rules on seismic prevention of Cultural heritage. In particular, the working group that chaired this research was composed by C. Gavarini, P. Angeletti, P. Baldi, R. Ballardini, F. Braga, A. Ceradini, R. Marnetto, T. Pagnoni, V. Petri.



**B**

**Scheda sismico strutturale**

INDIVIDUAZIONE DELL'OPERA

OPERA LOCALITA' SEC. di COSTR. N° D'ORDINE

1 C H I S I N I W 19 ROSCIOLI 35 41 39

10 V A L L E P O R 37 AC 1 DC

DESCRIZIONE SINTETICA

PIANTA DATI METRICI DESTINAZIONE ATTUALE

43 59

1 circolare lunghezza 44 032 m turismo

2 poligonale larghezza 47 18 m culto

3 rettangolare altezza 49 10 m abitazione

4 quadrata volume 51 04050 cm altro tipo

5 croce greca piani f.t. 56 04 n°

6 croce latina 58 si

7 altro tipo 59 nr

LOCALIZZAZIONE E CAUSE DEI PRINCIPALI DISSESTI

localizzazione	causa di lesione	causa
60	fondazioni	1 2 3 4
61	strutt. vertic.	1 2 3 4
62	strutt. orizz.	1 2 3 4
63	copertura	1 2 3 4

LOCALIZZAZIONE, ENTITA' E DIFFUSIONE DEI PRINCIPALI DISSESTI

localizzazione	entita'	diffusione
60-65	fondazioni	0 0
66-67	strutt. vertic.	0 1
68-69	strutt. orizz.	0 0
70-71	copertura	0 0

LOCALIZZAZIONE, ENTITA' E DIFFUSIONE DEL DEGRADO

localizzazione	entita'	diffusione
72-73	fondazioni	0 0
74-75	strutt. vertic.	1 1
76-77	strutt. orizz.	0 0
78-79	copertura	1 1

compilatore Antonio Ceradini data 13/05/1986

FONDAZIONI

	81	82	83	84
	TIPLOGIE COMUNITARIE	MATERIALI	TIPLOGIE DI LESIONI	INTERVENTI EFFETTUATI
A	sordoli	pietra	verticali	nessuno
B	posti	laterizio	orizzontali	infiltrazioni
C	piatta	legno	diagonali	microspelli
D	pali		incrociate	
E	CONTINUE			
F				
G				
H				
I				
J				
K				
L				
M				
N				
O				
P				
Q				
R				
S				
T				
U				
V				
W				
X				
Y				
Z				

STRUTTURE ORIZZONTALI

	101	102	103	104
	TIPLOGIE COMUNITARIE	MATERIALI	TIPLOGIE DI LESIONI	INTERVENTI EFFETTUATI
A	voluta a botte	pietra	// generatrici	nessuno
B	v. padiglione	laterizio	// generatrici	ricostruzione
C	v. crociera	legno	estradosso	sostituzione
D	v. lunettata	metallo	intradosso	tiranti
E	v. altro tipo		perfor. armate	
F	soffitto			iniezioni esp.
G				
H				
I				
J				
K				
L				
M				
N				
O				
P				
Q				
R				
S				
T				
U				
V				
W				
X				
Y				
Z				

STRUTTURE VERTICALI

	85	86	87	88
	TIPLOGIE COMUNITARIE	MATERIALI	TIPLOGIE DI LESIONI	INTERVENTI EFFETTUATI
A	pietra concia	pietra	verticali	nessuno
B	murat. mattoni	laterizio	orizzontali	contrefortini
C	murat. sacco	legno	diagonali	strutture
D		metallo	incrociate	perfor. armate
E				iniezioni esp.
F				iniezioni esp.
G				contreforti
H				cont. v. l. s.
I				
J				
K				
L				
M				
N				
O				
P				
Q				
R				
S				
T				
U				
V				
W				
X				

COPERTURE

	117	118	119	120
	TIPLOGIE COMUNITARIE	MATERIALI	TIPLOGIE DI LESIONI	INTERVENTI EFFETTUATI
A	piana	pietra	// generatrici	nessuno
B	velto	laterizio	// generatrici	ricostruzione
C	cupola	legno	estradosso	sostituzione
D		metallo	intradosso	tiranti
E				perfor. armate
F				iniezioni esp.
G				
H				
I				
J				
K				
L				
M				
N				
O				
P				
Q				
R				
S				
T				
U				
V				
W				
X				

Fig.5. Example of seismic-structural form used by Ceradini during the experimental campaign. (Ceradini, 1987)

annex was to relate the current building layout to its historical evolution in seismic terms. The difficulty of filling in this chronology leads Ceradini to define the realization of it as a “*methodology proposal*” in the of cultural heritage survey. At the end of the report, he finally identified some suggestion for a new form development.

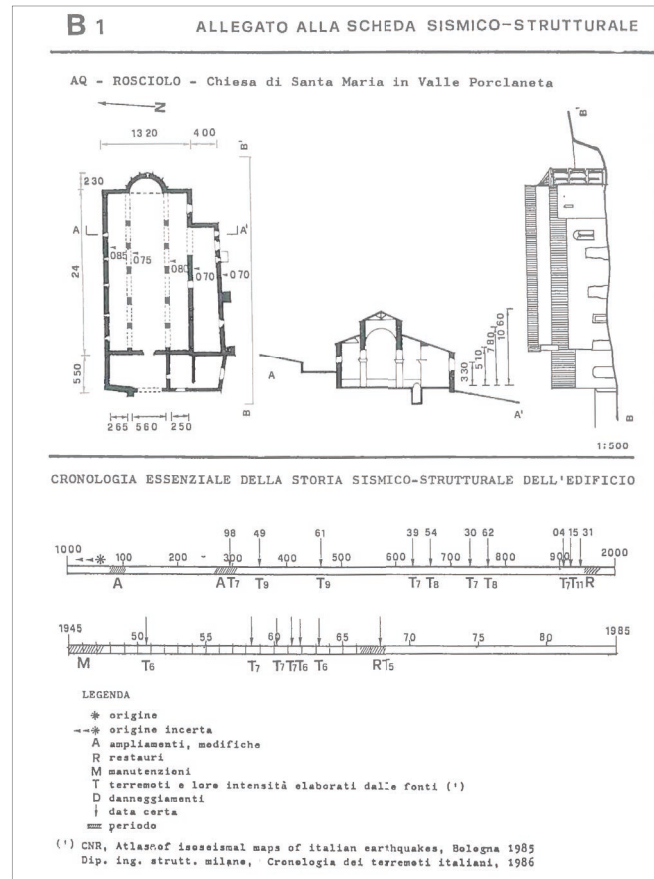

Fig.6. Example of the attachment to the seismic-structural form drawn up by Ceradini (Ceradini,1987)

A number of factors led in the second half of the '80s to a new moment of reflection. Firstly, the succession of several earthquakes in the previous years, (Parma 1983, Central Italy 1984 etc.) which had allowed the validation and calibration of the different methods studied for basic buildings. Moreover, the opportunity to compare first and second-level methods due to the real data collected, as well as the debate still being open among specialists, also contributed. This caused a general revision of the different methodologies, starting from the one adopted by GNDT for the first-level forms, but above all resulted in the conceptual and real separation between the acquisition of vulnerability data, now operated in a systematic way, and the methods of vulnerability assessment. The distinction between “first-level” and “second-level” applied according to the methodology for vulnerability assessment is replaced by a distinction linked to the completeness of the data collected.

Attributing a cognitive activity to the moment of the data survey, that is the acquisition of useful data for buildings knowledge, as well as to a second moment of vulnerability assessment dealing more with the data interpretation in a forecasting key, the goal becomes to collect data at different levels of completeness and accuracy in order to be used in the future for the assessment of vulnerability through multiple methodologies (Corsanego & Gavarini,1993). This step, which is fundamental for the future design of operational survey

tools, is confirmed by the new GNDT survey models of 1989 where, while substantially reconfirming the data to be surveyed (Fig. 7), any reference to the vulnerability analysis methodologies is eliminated.

GRUPPO NAZIONALE PER LA DIFESA DAI TERREMOTI (G.N.D.T.) - C.N.R.  
 Scheda di 1° livello per il rilevamento dell'esposizione e della vulnerabilità degli edifici

**Sezione 1 - DATI RELATIVI ALLA SCHEDA**  
 Cod. ISTAT Provincia \_\_\_\_\_  
 Cod. ISTAT Comune \_\_\_\_\_  
 Comune \_\_\_\_\_

**Sezione 2 - LOCALIZZAZIONE EDIFICIO**  
 Cod. ISTAT Sez. Cens. \_\_\_\_\_  
 RIFERIMENTO CATASTALE  
 Foglio \_\_\_\_\_ Mappale \_\_\_\_\_ Particella \_\_\_\_\_  
 CARTOGRAFIA DI RILEVAZIONE  
 Foglio \_\_\_\_\_ Aggregato \_\_\_\_\_ Edificio \_\_\_\_\_  
 URBANISTICA  
 Zona di piano \_\_\_\_\_ Piano attu. \_\_\_\_\_ Vincoli \_\_\_\_\_

**Sezione 3 - DATI METRICI**  
 Altezza massima fuori terra valutata in gronda (m) \_\_\_\_\_  
 Altezza minima fuori terra valutata in gronda (m) \_\_\_\_\_  
 Larghezza strada fronte principale (m) \_\_\_\_\_

**Sezione 4 - USO**  
 Totale unità d'uso \_\_\_\_\_  
 Stato dell'edificio \_\_\_\_\_  
 Condizioni d'uso \_\_\_\_\_

**Sezione 5 - DATI METRICI (cont.)**  
 Residenza 2 no \_\_\_\_\_  
 Abitazioni occupate \_\_\_\_\_  
 Abitazioni libere \_\_\_\_\_  
 Abitazioni occup. salt. \_\_\_\_\_  
 Denom. dell'edificio \_\_\_\_\_  
 Intensità d'uso \_\_\_\_\_  
 Util. Potenz. \_\_\_\_\_  
 Bacino di utenza \_\_\_\_\_

Scheda di 1° livello per il rilevamento dell'esposizione e della vulnerabilità degli edifici

**Sezione 5 - ETÀ DELLA COSTRUZIONE - INTERVENTI**  
 Classi di età Interventi  
 A prima del '19 \_\_\_\_\_  
 B '19 - '45 \_\_\_\_\_  
 C '46 - '60 \_\_\_\_\_  
 D '61 - '71 \_\_\_\_\_  
 E '72 - '75 \_\_\_\_\_  
 F '76 - '80 \_\_\_\_\_  
 G dopo '80 \_\_\_\_\_  
 H \_\_\_\_\_

**Sezione 6 - STATO DELLE FINITURE E IMPIANTI**  
 E Efficiente \_\_\_\_\_  
 N Non efficiente \_\_\_\_\_  
 Z Non esistenti \_\_\_\_\_

**Sezione 7 - TIPOLOGIA STRUTTURALE**  
 Mur. a sacco \_\_\_\_\_  
 Mur. a sacco con spigoli, mazzette e ricorsi \_\_\_\_\_  
 Mur. pietra sbalzata \_\_\_\_\_  
 Mur. pietra sbalzata con rinforzi c.s. \_\_\_\_\_  
 Mur. pietra arrotondata \_\_\_\_\_  
 Mur. pietra arrotondata con rinforzi c.s. \_\_\_\_\_  
 Mur. blocchetti tufo o pietra ben squadrate \_\_\_\_\_  
 Mur. blocchetti calc. inerti pesanti \_\_\_\_\_  
 Mur. blocchetti calc. inerti leggeri \_\_\_\_\_  
 Mur. mattoni pieni o multicolori \_\_\_\_\_  
 Mur. mattoni forati \_\_\_\_\_  
 Pareti calc. non armate \_\_\_\_\_  
 Pareti calc. armate \_\_\_\_\_  
 Teteli di c.a. non temporanei \_\_\_\_\_  
 Teteli di c.a. con temporeture deboli \_\_\_\_\_  
 Teteli di c.a. con temporeture consistenti \_\_\_\_\_  
 Ossatura metallica \_\_\_\_\_  
 Miste \_\_\_\_\_

**Sezione 8 - ESTENSIONE E LIVELLO DEL DANNO**  
 Evento in data \_\_\_\_\_  
 Estensione del danno \_\_\_\_\_  
 Livello del danno \_\_\_\_\_

GRUPPO NAZIONALE PER LA DIFESA DAI TERREMOTI (G.N.D.T.) - C.N.R.  
 Scheda di 1° livello per il rilevamento dell'esposizione e della vulnerabilità degli edifici

**Sezione 1 - DATI RELATIVI ALLA SCHEDA**  
 Cod. ISTAT Provincia \_\_\_\_\_  
 Cod. ISTAT Comune \_\_\_\_\_  
 Comune \_\_\_\_\_

**Sezione 2 - LOCALIZZAZIONE EDIFICIO**  
 Cod. ISTAT sezione Censuaria \_\_\_\_\_  
 RIFERIMENTO CATASTALE  
 Foglio \_\_\_\_\_ Mappale \_\_\_\_\_ Particella \_\_\_\_\_  
 CARTOGRAFIA DI RILEVAZIONE  
 Foglio \_\_\_\_\_ Aggregato \_\_\_\_\_ Edificio \_\_\_\_\_  
 URBANISTICA  
 Zona di piano \_\_\_\_\_ Piano attuativo \_\_\_\_\_ Vincoli \_\_\_\_\_

**Sezione 3 - DATI METRICI**  
 Altezza massima fuori terra valutata alla gronda (m) \_\_\_\_\_  
 Altezza minima fuori terra valutata alla gronda (m) \_\_\_\_\_  
 Larghezza stradale fronte principale (m) \_\_\_\_\_

**Sezione 4 - USO**  
 Totale unità d'uso \_\_\_\_\_  
 Stato dell'edificio \_\_\_\_\_  
 Totale unità d'uso \_\_\_\_\_

**Sezione 5 - DATI METRICI (cont.)**  
 Residenza 2 no \_\_\_\_\_  
 Abitazioni occupate \_\_\_\_\_  
 Abitazioni libere \_\_\_\_\_  
 Abitazioni occup. salt. \_\_\_\_\_  
 Denom. dell'edificio \_\_\_\_\_  
 Intensità d'uso \_\_\_\_\_  
 Utilizzazione Potenziale \_\_\_\_\_  
 Bacino di utenza \_\_\_\_\_

Scheda di 1° livello per il rilevamento dell'esposizione e della vulnerabilità degli edifici

**Sezione 5 - ETÀ DELLA COSTRUZIONE - INTERVENTI**  
 Classi di età Interventi  
 A prima del '19 \_\_\_\_\_  
 B '19 - '45 \_\_\_\_\_  
 C '46 - '60 \_\_\_\_\_  
 D '61 - '71 \_\_\_\_\_  
 E '72 - '75 \_\_\_\_\_  
 F '76 - '81 \_\_\_\_\_  
 G dopo '81 \_\_\_\_\_  
 H \_\_\_\_\_

**Sezione 6 - STATO DELLE FINITURE E IMPIANTI**  
 E Efficiente \_\_\_\_\_  
 N Non efficiente \_\_\_\_\_  
 Z Non esistenti \_\_\_\_\_

**Sezione 7 - TIPOLOGIA STRUTTURALE**  
 Muratura a sacco \_\_\_\_\_  
 Muratura a sacco con spigoli, mazzette, ricorsi \_\_\_\_\_  
 D Muratura pietra sbalzata \_\_\_\_\_  
 E Muratura pietra sbalzata con rinforzi c.s. \_\_\_\_\_  
 F Muratura pietra arrotondata \_\_\_\_\_  
 G Muratura pietra arrotondata con rinforzi c.s. \_\_\_\_\_  
 H Muratura blocchetti calc. inerti pesanti \_\_\_\_\_  
 I Muratura blocchetti calc. inerti leggeri \_\_\_\_\_  
 L Muratura mattoni pieni o multicolori \_\_\_\_\_  
 M Muratura mattoni forati \_\_\_\_\_  
 N Pareti calcestruzzo non armato \_\_\_\_\_  
 O Pareti calcestruzzo armato \_\_\_\_\_  
 P Teteli di c.a. non temporanei \_\_\_\_\_  
 Q Teteli di c.a. con temporeture deboli \_\_\_\_\_  
 R Teteli di c.a. con temporeture consistenti \_\_\_\_\_  
 S Ossatura metallica \_\_\_\_\_  
 U Miste \_\_\_\_\_  
 V \_\_\_\_\_

**Sezione 8 - ESTENSIONE E LIVELLO DEL DANNO**  
 Evento in data \_\_\_\_\_  
 Estensione del danno \_\_\_\_\_  
 Livello del danno \_\_\_\_\_

Fig.7. Comparison between the 1986 and 1999 GNDT Level I forms. As can be seen, the data to be recorded are almost unchanged; what has been modified is the reference to precise methodologies of vulnerability analysis in the manual.

In this same period, next to the form for the basic buildings survey, GNDT experiments on-site with a new form for cultural heritage, in particular for churches<sup>10</sup>. This instrument was drafted and tested by the GNDT Research Unit (hereafter RU), which operated from 1988 to 1998, headed by Prof. Doglioni (CNR-GNDT, 1990). In addition to Doglioni himself, the research group includes A. Bellina, A. Moretti, P. Furini, A. Del Colle and others, but above all P. Angeletti and V. Petrini who had already taken part in the first experiments carried out in 1986 at the behest of the National Committee For The Prevention Of Cultural Heritage From Seismic Risk. Therefore, it should not be unexpected that the structural-seismic chronology, advanced as a proposed method in the first experiment and then included among the appendices, within this new operational tool finds its placement among the first records of what is defined as “the preliminary form”. Indeed, the tool developed by Doglioni’s RU inherited reflections and doubts identified in the previous experimentation and solved them (Doglioni et al., 1994). The solution was found by creating a tool that was not configured as the sum of two different instruments designed for different purposes from the vulnerability survey (ICCD form A + adapted seismic-structural form), but as a single operational tool capable of providing homogeneous answers regardless of the typological-constructive complexity of the asset surveyed.

The design of this new tool is based on the analysis of data produced by the Friuli earthquake more than 10 years after the event (Doglioni et al., 1994). The large temporal distance between the study and the earthquake highlighted the need first to screen an initial sample of almost 350 churches in order to identify those buildings for which it was possible to achieve a detailed analysis through the presence of a good amount of data, especially photographic data. This screen reduced the sample to 45 buildings which were analysed in their architectural history, in their constructive characteristics, in their geometric configuration and, above all, in their cracks. This allowed the development of a first prototype, subsequently refined during the survey campaign after the Emilia-Romagna earthquake (1987). On this occasion, indeed, the Region launched a large vulnerability census campaign which lasted from 1988 to 1993. In particular, the form was used in the context of the “Progetto Finalizzato per le indagini di vulnerabilità e per la stima degli interventi di consolidamento” (1987-1990)<sup>11</sup> after which, in March 1990, the “Istruzioni per la compilazione della scheda di rilevamento vulnerabilità e danno delle chiese” (CNR-GNDT, 1990) were officially published. The instrument drafted by the research group was conceptually divided into two large sections and could contain a variable number of forms according to the church configuration, while the second was graphic, i.e., it had to contain diagrams and drawings of the building and development of cracks. The preliminary form, within which the second subsection was specifically designed for the abovementioned seismic-structural chronology, collected the basic metrical and typological data as well as the definition of the constitutive elements in which to break down each building. This decomposition stemmed from the building configuration according to a precise scheme (Fig. 8). The preliminary form was then followed by a series of specific forms for each constituent element identified and a final one containing the damage survey.

.....  
10 The decision to focus the work on churches stems from the observation, after the 1987 earthquake, that this building type suffers significant seismic damage even for non-severe intensity. In other words, it is more vulnerable to seismic action, due to its spatial configuration.  
11 Resolution of Regional Council 6538/1988

The form was therefore structured in three distinct survey phases at the end of which it was possible to carry out a vulnerability analysis. These were synthetically outlined as:

- 1) detailed building description, including geometry, materials, building techniques and cracks;
- 2) building subdivision in macro-elements (Fig. 9);
- 3) identification of the possible damage modes associated with the macro-elements.

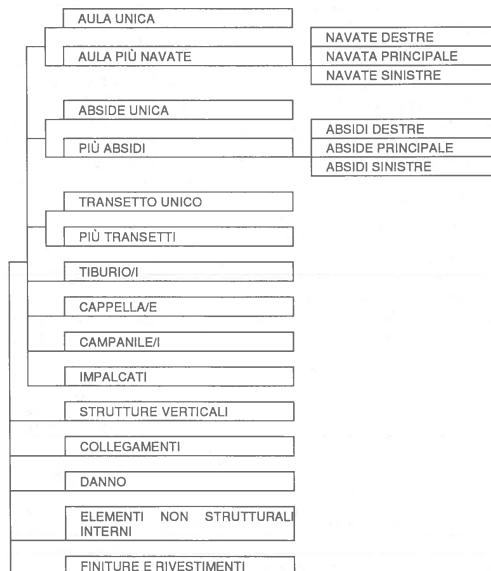

Fig.8. Articulation scheme of the specific forms related to the church's constituent elements (Doglioni et al., 1994:42)

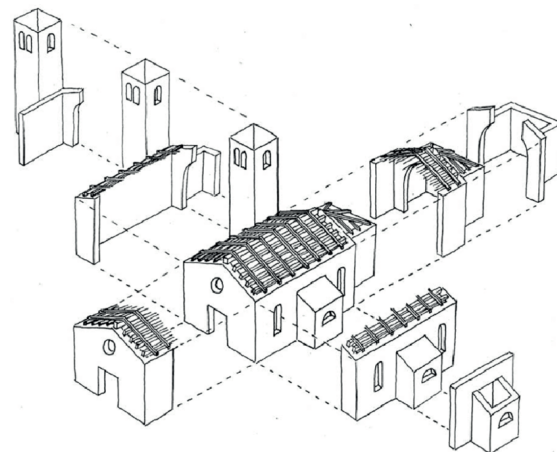

Fig.9. Example of a church decomposition into its corresponding macro-elements. (Ferrini & Moretti, 2004:24)

Apart from the graphic form formulation (Fig. 10), undoubtedly the most important methodological point in this proposal is the churches subdivision in homogeneous parts from the seismic-structural point of view, the so-called macro-elements. This distinction, even considering the evident non-box-like behaviour of historical buildings, has remained in all the following elaborations concerning the scheduling tools for churches.

In the late 80's and early 90's the damage and vulnerability analysis issue shifted its interest from basic buildings to other buildings such as monumental buildings with particular reference, as seen above, to ecclesiastical buildings, industrial buildings (Alessi et al., 1993), bridges (Braga et al., 1987) and infrastructure (Corsanego & Del Grosso, 1987; Ciampoli et al., 1992). Then, the small and medium intensity earthquakes that occurred in those years lead to the creation of several databases filled with information on the vulnerability and damage of residential buildings, monuments, and more. With particular reference to historical monumental buildings, several contributions were made in the '90s.

From one side, the research carried out by Giuffrè (Giuffrè, 1993; Giuffrè & Carocci, 1996) on the vulnerability of the historical centres continued in order to define practice-codes for a conscientious and respectful intervention of the built environment, also taking in account buildings-performances improvement to the seismic action. On the other hand, at the beginning of the 90's, Prof. Gavarini (1991) presented a first level survey form designed not only for churches, but for entire monumental heritage. This first generic tool for historic buildings and monuments was included in a broader project called the "Sistema nazionale per la Catalogazione, il Rillevamento, la Sorveglianza e la Manutenzione programmata dei

SCHEDA AULA A PIU' NAVATE scheda n° / / foglio /

Sez. 1 - Dati generali n. navate :

navata	lungh.	largh.	alt. min.	alt. max.

Sez. 3 - Elementi di separazione delle navate

1) elementi verticali

colonnato	n'	tipo	a	b	mat.	h	int.	s.c.

2) elementi orizzontali

colonnato	archi	n'	mat.	f	mur.	spesse.	s.c.

tipologia colonne:                  tipo. archi:                  materiale:

1 base circolare                  1 sesto acuto                  A cotto  
 2 base rett. o quadrata              2 tutto sesto                  B pietra squadrata  
 3 base composta o                  3 s. ribassato                  C pietra sbazzata  
   a fasci                                  4 architravi                  D tufo  
 4 colonne binate                      5 altro                              E marmo  
 5 altro                                      6 s. rialzato                  F altro

SCHEDA AULA UNICA/NAVATA CENTRALE scheda / / / foglio /

Sez. 1 - Copertura

1) sping. / non sping. / potenzialmente sping. /	B. C.
2) incl. falda [%] / / / / / 3) manto [kg/mq] / / / / /	/ /
4) tipo di impalcato / / / / /	/ /
5) ordit. 1° ordine / / / / / intersasse / / / / /	/ /
6) ordit. 2° ordine / / / / /	/ /
7) ordit. 3° ordine / / / / /	/ /
8) luce per il 1° ordine / / / / / sez. / / / / / x / / / / /	/ /
9) collegamenti fra elementi del 1° ordine / / / / /	/ /
10) coll. 1° ordine - strutt. vert. / / / / /	/ /
11) elementi non strutturali / / / / / tipo / / / / /	/ /

Sez. 2 - Volte / / n' / / / /

n'	tipo	cat.	mat.	lungh	largh	f	coll	cost

Sez. 3 Controsoffitti

tipo / / / / /	coll. capriate / / / / /	coll. incerto / / / / /	strutt. propria / / / / /	s.c. / / / / /
----------------	--------------------------	-------------------------	---------------------------	----------------

Sez. 4 - Archi trasversali

n'	tipo	mat.	l	d	f	s	cat.	s.c.

Sez. 5 - Fondazioni terr. / / / / /

1) cont. / / alt. / / / / / base / / / / / prof. / / / / /

2) plinti / / alt. / / / / / base / / / / / x / / / / / prof. / / / / /

3) pali / / tipo / / / / / l / / / / / # / / / / /

4) terrapieno / / su terr. riporto / / / / / [tutto = 1 in parte = 2]

SCHEDA ABSIDE UNICA/ABSIDE PRINCIPALE scheda / / / / foglio /

Sez. 1 - Copertura

1) sping. / non sping. / potenzialmente sping. /	B. C.
2) incl. falda [%] / / / / / 3) manto [kg/mq] / / / / /	/ /
4) tipo di impalcato / / / / /	/ /
5) ordit. 1° ordine / / / / / intersasse / / / / /	/ /
6) ordit. 2° ordine / / / / /	/ /
7) ordit. 3° ordine / / / / /	/ /
8) luce per il 1° ordine / / / / / sez. / / / / / x / / / / /	/ /
9) collegamenti fra elementi del 1° ordine / / / / /	/ /
10) coll. 1° ordine - strutt. vert. / / / / /	/ /
11) elementi non strutturali / / / / / tipo / / / / /	/ /

Sez. 2 - Volte / / n' / / / /

n'	tipo	cat.	mat.	lungh	largh	f	coll	cost

Sez. 3 Controsoffitti

tipo / / / / /	coll. capriate / / / / /	coll. incerto / / / / /	strutt. propria / / / / /	s.c. / / / / /
----------------	--------------------------	-------------------------	---------------------------	----------------

Sez. 4 - Archi trasversali

n'	tipo	mat.	l	d	f	s	cat.	s.c.

Sez. 5 - Fondazioni terr. / / / / /

1) cont. / / alt. / / / / / base / / / / / prof. / / / / /

2) plinti / / alt. / / / / / base / / / / / x / / / / / prof. / / / / /

3) pali / / tipo / / / / / l / / / / / # / / / / /

4) terrapieno / / su terr. riporto / / / / / [tutto = 1 in parte = 2]

SCHEDA NAVATA / / / / scheda / / / / / foglio /

Sez. 1 - Copertura

1) sping. / non sping. / potenzialmente sping. /	B. C.
2) incl. falda [%] / / / / / 3) manto [kg/mq] / / / / /	/ /
4) tipo di impalcato / / / / /	/ /
5) ordit. 1° ordine / / / / / intersasse / / / / /	/ /
6) ordit. 2° ordine / / / / /	/ /
7) ordit. 3° ordine / / / / /	/ /
8) luce per il 1° ordine / / / / / sez. / / / / / x / / / / /	/ /
9) collegamenti fra elementi del 1° ordine / / / / /	/ /
10) coll. 1° ordine - strutt. vert. / / / / /	/ /
11) elementi non strutturali / / / / / tipo / / / / /	/ /

Sez. 2 - Volte / / n' / / / /

n'	tipo	cat.	mat.	lungh	largh	f	coll	cost

Sez. 3 Controsoffitti

tipo / / / / /	coll. capriate / / / / /	coll. incerto / / / / /	strutt. propria / / / / /	s.c. / / / / /
----------------	--------------------------	-------------------------	---------------------------	----------------

Sez. 4 - Archi trasversali

n'	tipo	mat.	l	d	f	s	cat.	s.c.

Sez. 5 - Fondazioni terr. / / / / /

1) cont. / / alt. / / / / / base / / / / / prof. / / / / /

2) plinti / / alt. / / / / / base / / / / / x / / / / / prof. / / / / /

3) pali / / tipo / / / / / l / / / / / # / / / / /

4) terrapieno / / su terr. riporto / / / / / [tutto = 1 in parte = 2]

Fig.10. Reductions in some of the specific forms set up for churches (Doglioni, Moretti, Petri, 1994:66).

monumenti”<sup>12</sup> (CA.RI.S.MA ). The aim of this ambitious project was to create a multilevel system for the data collection on cultural heritage (often already started without any criteria of homogeneity and in separate databases) which would be a versatile system able to create a dialogue between the different disciplinary languages. Indeed, the 90’s were also the years in which was clearly felt the need to bring the numerous databases, including all those that arose after the several seismic events occurred, into higher-level structures aimed to unify and homogenize data from different forms in order to compare them and to be able to carry out analyses at a national scale. Within the CA.RI.S.MA project, in collaboration with Antonio Corsanego, Gavarini proposed a survey form for monumental assets. The form is declaredly a first-level form, i.e., a sufficient but not exhaustive data collection regarding Monumental Heritage. This is the reason why it is composed of only 4 pages<sup>13</sup> (Fig 11).

Fig.11. Reductions of a part of the type form studied for the monuments by Gavarini and Corsanego (Gavarini, 1991:185)

On the initial page, the page of the main geomorphologic data collection, alongside information stemming from previous research such as the seismic-structural chronology, for the first time appear the fields of crowding and urban location. A distinction is expressed for the first time between “Monument Risk (RM)” and “People Risk (RP)”, where the first is the building vulnerability, the second is the risk due to the possible presence of people. In addition, its placement of being isolated or in an urban stock is taken into account, as well as the accessibility by emergency vehicles. However, it must be mentioned that, already in 1991, Gavarini underlined how the “People Risk” should not lead to interventions aimed

.....  
 12 National System for the Cataloguing, Survey, Monitoring and Programmed Maintenance of Monuments  
 13 On the contrary, for example, even if the second-level was not openly declared for it, the form developed by Professor Doglioni was a multiple set of forms with from 1 to 4 sides per form.

at what today we would call seismic retrofitting, but to interventions which, respecting the conservative requirements, would limit the monuments access with even temporary measures. Concerning, then, the damage survey, similarly to what is still present in the previous forms on churches, we are faced again with a collection based on the cracks description, hereby classified by vertical structures, horizontal structures and stairs.

It is worth mentioning, then, the study carried out by Guccione, Nappi and Recchia (1998), which was an ideal follow-up to Giuseppe Proietti's cataloguing work of the Cultural heritage damaged by the Irpinia and Basilicata earthquake in 1980 (Ministero per i beni culturali e ambientali. Ufficio centrale beni archivistici, Proietti, 1994). Even in this case, as in Doglioni's study, the analysis was carried out many years after the earthquake on the basis of previously collected data. Similarly to previous studies, the final goal of the analysis was to define a method of damage assessment (Fig. 12) that would subsequently allow for the identification of typical collapse mechanisms in historic buildings. What distinguished this study from others was the effort to develop a unified tool for churches, stately buildings, and archaeological assets.

rif.	COMUNE:	Intensità delle scosse						
	Monumento:	TIPOLOGIA DEI DANNI						
		1	2	3	4	5	6	7
	ELEMENTI STRUTTURALI	CEDIMENTI	CROLLI	DISTACCHI	DEFORMAZIONI	FESSURAZIONI	LESIONI DIFFUSE	SCONNESSIONI
<b>A</b>	<b>FONDAZIONI</b>							
a.1	terreno di sedime							
b.2	struttura fondale							
<b>B</b>	<b>STRUTTURE VERTICALI</b>							
b.1	murature, pilastri, colonne							
<b>C</b>	<b>STRUTTURE ORIZZONTALI</b>							
c.1	solai							
d.2	archi e volte							
<b>D</b>	<b>STRUTTURE DI COPERTURA</b>							
d.1	tetti							
d.2	cupole							
<b>E</b>	<b>STRUTTURE DI COLLEGAMENTO</b>							
e.1	scale							
	<b>TOTALE</b>							
estensione del danno:								
0=non riscontrato 1= danno parziale <50% 2= danno esteso>50%								

Fig.12. Form studied by Guccione, Nappi and Recchia (Guccione, 1998:60)

But it was the 1997 Umbria-Marche earthquake that once again challenged the tools available for both cultural and basic buildings.

Between 1996 and 1997 the research activities of GNDT, questioned all previous acquisitions due to a solid and, for certain purposes, accurate surveying tool such as the GNDT Level 1 Basic building Survey. The aim of which was twofold:

- 1) Overcome the spatially limited nature of the existing tools
- 2) Correlate the judgment of practicability to the operations of damage surveying.



These research activities should be carried out both on basic and on specialised buildings. As for the church form drawn up in 1989 is concerned, the on-site test in the emergency phase demonstrated its unsuitability for the accomplishment of a quick survey, i.e., the inability to collect all the basic information required as quickly and safely as possible. The filling out of multiple forms in varying and non-quantifiable amounts was not only unsuitable for the timeliness of the survey, but also from the perspective of planning activities. The high quantity of labour-intensive forms could be filled in either as a desk-based operation or as an operation carried out at a distance from the seismic events. The former could be referred to as the first prototype phase, while the latter could be referred to as the test phase which was carried out after the 1987 earthquake. The Emilia earthquake campaign of 1987 was run between 1987 and 1993 while this procedure was developed only in 1989, two years after the earthquake.

The requirement, imposed in 1997, was to provide a “*quick and synthetic tool*” (Lagomarsino et al., 1997), different from the one already provided by GNDT. This led the GNDT RU in Genoa, headed by Professor Sergio Lagomarsino, to develop a new survey instrument based on an experience gained in 1996 (Angeletti et al., 1997). Through this tool it was possible to quantify the damage and judge the practicability, according to the research on basic buildings survey. It also suggests the necessary safety measures both for the protection of public health and to avoid further loss of cultural heritage.

In spite of its conciseness, this was a second-level form. It was based on a number of parameters representing both possible kinematics on macro-elements and morphological or constructive characteristics representing anti-seismic measures or further load factors (Fig. 13). The survey therefore led to the definition of two synthetic indices, the damage index and the vulnerability one. The first value represented the average damage level suffered, the second the church tendency to be damaged. While the first one was an index of the observed damage to be used for the determination of action priorities, the second one was intended as an absolute value of vulnerability which was able to foresee the damage level for fixed macro-seismic intensities, through to correlation curves.

The day after it had been developed, the instrument was presented at the Mixed Operating Centre (COM) of Foligno. The research unit offered to carry out a survey campaign for that first day with the new instrument in order to verify its effectiveness. At the end of the day, the RU had surveyed 20 churches, defining not only the damage level, but also the judgment of practicability and the safety measures. The first day provided the check of the new system feasibility. In line with what was pursued by the GNDT, it overcame the previous approach of typological nature<sup>14</sup>. This approach assumed the recognition of building damage by analogy with what happened on an architecturally similar building. Instead, the new forms focused not on the cracks' description, location and extension, but on the recognition of the kinematism activated, “*the vulnerability essence*” (Podestà, 2001) of which the cracks are an expression. An interesting aspect of the activities carried out in this new methodology test is the timeframe of the RU, that amounted in the first work day to 20 churches for two teams. Basing on it, it was estimated that an average survey would consist of 6/8 churches per team

.....

<sup>14</sup> We are not referring here to the concept of building typology of the Muratori and Caniggia school, but to an engineering approach to buildings. It is based on the structural and behavioural analogy among buildings with the same constructive features.

per day of work. This means that considering an average of 8 working hours per day and an excellent, though not probable<sup>15</sup>, territorial distribution of the surveys to be carried out (minimum transfers), the estimate provided by the RU is 1 hour of on-site survey to complete a second-level form<sup>16</sup>.

<b>1. RIBALTAMENTO DELLA FACCIATA</b>	<input type="checkbox"/>	<b>2. MARTELLAMENTO SOMMITÀ FACCIATA</b>	<input type="checkbox"/>
DISTACCO DELLA FACCIATA DALLE PARETI	<input type="checkbox"/> <input type="checkbox"/> <input type="checkbox"/>	LESIONI NELLA ZONA ALTA DELLA FACCIATA	<input type="checkbox"/> <input type="checkbox"/> <input type="checkbox"/>
<input type="checkbox"/> Ammorsamento scadente facciata / muri della navata		<input type="checkbox"/> Facciata indebolita da grandi aperture	<input type="checkbox"/> <input type="checkbox"/>
<input type="checkbox"/> Assenza di catene longitudinali o contrafforti efficaci	<input type="checkbox"/> <input type="checkbox"/>	<input type="checkbox"/> Assenza di un collegamento con la copertura	<input type="checkbox"/> <input type="checkbox"/>
<b>3. MECCANISMI NEL PIANO DELLA FACCIATA</b>	<input type="checkbox"/>	<b>4. RISPOSTA SISMICA TRASVERSALE</b>	<input type="checkbox"/>
LESIONI INCLINATE, VERTICALI, ARCUATE	<input type="checkbox"/> <input type="checkbox"/> <input type="checkbox"/>	LESIONI NEGLI ARCONI, PARETI DEFORMATE	<input type="checkbox"/> <input type="checkbox"/> <input type="checkbox"/>
<input type="checkbox"/> Presenza di molte aperture (anche tamponate)		<input type="checkbox"/> Pareti laterali di elevata snellezza	<input type="checkbox"/> <input type="checkbox"/>
<input type="checkbox"/> Possibilità di rotazione delle pareti laterali	<input type="checkbox"/> <input type="checkbox"/>	<input type="checkbox"/> Assenza di catene trasversali o di contrafforti efficaci	<input type="checkbox"/> <input type="checkbox"/>
<b>5. ARCO TRIONFALE</b>	<input type="checkbox"/>	<b>6. VOLTE DELL'AULA</b>	<input type="checkbox"/>
LESIONI IN CHIAVE O ALLE RENI	<input type="checkbox"/> <input type="checkbox"/> <input type="checkbox"/>	VOLTE LESIONATE, DISTACCHI DAGLI ARCONI	<input type="checkbox"/> <input type="checkbox"/> <input type="checkbox"/>
<input type="checkbox"/> Arco di spessore inadeguato o di muratura scadente	<input type="checkbox"/> <input type="checkbox"/>	<input type="checkbox"/> Volte eccessivamente ribassate	<input type="checkbox"/> <input type="checkbox"/>
<input type="checkbox"/> Catene assenti, mal poste; pareti di taglio deboli	<input type="checkbox"/> <input type="checkbox"/>	<input type="checkbox"/> Presenza carichi concentrati trasmessi dalla copertura	<input type="checkbox"/> <input type="checkbox"/>
<b>7. MARTELLAMENTO DELLA COPERTURA</b>	<input type="checkbox"/>	<b>8. CUPOLA</b>	<input type="checkbox"/>
SCORRIMENTI TRAVI; SCONNESSIONI CORDOLI	<input type="checkbox"/> <input type="checkbox"/> <input type="checkbox"/>	LESIONI IN: CUPOLA, TAMBURO, LANTERNA	<input type="checkbox"/> <input type="checkbox"/> <input type="checkbox"/>
<input type="checkbox"/> Copertura spingente; nuova copertura di maggior peso	<input type="checkbox"/> <input type="checkbox"/>	<input type="checkbox"/> Tamburo molto alto e con grandi aperture	<input type="checkbox"/> <input type="checkbox"/>
<input type="checkbox"/> Assenza collegamento travi/muratura	<input type="checkbox"/> <input type="checkbox"/>	<input type="checkbox"/> Assenza di cerchiatura o di contrafforti esterni	<input type="checkbox"/> <input type="checkbox"/>
<b>9. RIBALTAMENTO DELL'ABSIDE</b>	<input type="checkbox"/>	<b>10. VOLTE DEL PRESBITERIO O DELL'ABSIDE</b>	<input type="checkbox"/>
LESIONI VERTICALI O ARCUATE PARETI ABSIDE	<input type="checkbox"/> <input type="checkbox"/> <input type="checkbox"/>	LESIONI NELLA VOLTA O NEL CATINO ABSIDALE	<input type="checkbox"/> <input type="checkbox"/> <input type="checkbox"/>
<input type="checkbox"/> Assenza di cerchiatura o incatenamento	<input type="checkbox"/> <input type="checkbox"/>	<input type="checkbox"/> Volte eccessivamente ribassate	<input type="checkbox"/> <input type="checkbox"/>
<input type="checkbox"/> Indebolimento per le molte aperture nelle pareti	<input type="checkbox"/> <input type="checkbox"/>	<input type="checkbox"/> Presenza di carichi concentrati dalla copertura	<input type="checkbox"/> <input type="checkbox"/>
<b>11. RIBALTAMENTO PARETI DI ESTREMITÀ IN ALTRE PARTI DELLA FABBRICA</b>	<input type="checkbox"/>	<b>12. INTERAZIONI IN PROSSIMITÀ DI DISCONTINUITÀ MURARIE</b>	<input type="checkbox"/>
DISTACCO PARETI DI ESTREMITÀ	<input type="checkbox"/> <input type="checkbox"/> <input type="checkbox"/>	MOVIMENTO NEI GIUNTI O LESIONI MURATURA	<input type="checkbox"/> <input type="checkbox"/> <input type="checkbox"/>
<input type="checkbox"/> Ammorsamento scadente tra parete e muri ortogonali	<input type="checkbox"/> <input type="checkbox"/>	<input type="checkbox"/> Elevata differenza di rigidità tra i due corpi	<input type="checkbox"/> <input type="checkbox"/>
<input type="checkbox"/> Assenza di catene o di contrafforti efficaci	<input type="checkbox"/> <input type="checkbox"/>	<input type="checkbox"/> Assenza di ammorsamento o di catene	<input type="checkbox"/> <input type="checkbox"/>
<b>13. ROTTURA A TAGLIO DELLE PARETI</b>	<input type="checkbox"/>	<b>14. TORRE CAMPANARIA</b>	<input type="checkbox"/>
LESIONI INCLINATE O LUNGO DISCONTINUITÀ LOCALI (VECCHIE APERTURE, ecc.)	<input type="checkbox"/> <input type="checkbox"/> <input type="checkbox"/>	LESIONI VICINO AL CONTATTO CON LA CHIESA, LESIONI VERTICALI, ESPULSIONE SPIGOLO	<input type="checkbox"/> <input type="checkbox"/> <input type="checkbox"/>
<input type="checkbox"/> Muratura scadente o di limitato spessore	<input type="checkbox"/> <input type="checkbox"/>	<input type="checkbox"/> Mancanza di connessione murature/torre	<input type="checkbox"/> <input type="checkbox"/>
<input type="checkbox"/> Forti indebolimenti per la presenza di aperture	<input type="checkbox"/> <input type="checkbox"/>	<input type="checkbox"/> Muratura degradata, scadente, di limitato spessore	<input type="checkbox"/> <input type="checkbox"/>
<b>15. CELLA CAMPANARIA</b>	<input type="checkbox"/>	<b>16. AGGETTI (VELA, GUGLIE, STATUE)</b>	<input type="checkbox"/>
LESIONI ARCHI; ROTAZIONI/SCORRIMENTI RITTI	<input type="checkbox"/> <input type="checkbox"/> <input type="checkbox"/>	ROTAZIONI PERMANENTI O SCORRIMENTI	<input type="checkbox"/> <input type="checkbox"/> <input type="checkbox"/>
<input type="checkbox"/> Assenza catene o cerchiatura; piedritti snelli	<input type="checkbox"/> <input type="checkbox"/>	<input type="checkbox"/> Assenza di contrafforti o di altri collegamenti	<input type="checkbox"/> <input type="checkbox"/>
<input type="checkbox"/> Copertura pesante o comunque spingente	<input type="checkbox"/> <input type="checkbox"/>	<input type="checkbox"/> Elevata snellezza dell'oggetto	<input type="checkbox"/> <input type="checkbox"/>

Fig.13. Macroelements and mechanisms considered in the new survey tool studied after Lunigiana and Garfagnana seismic activity ( Lagomarsio et al., 1997:71).

Also with reference to the basic buildings survey, as previously mentioned, the 1997 earthquake in Marche and Umbria was the test-case for a new survey tool in the emergency phase, the AeDES form.

Undoubtedly, the operative-quick instrument nature was already in line with the existing tools for the basic building survey<sup>17</sup>, but the “*descriptive*” approach, based on the identification of the building techniques, made them difficult to apply to large areas where precisely the building techniques could vary considerably. Again, as in the case of the churches form, the data type to be collected in the survey campaign is modified. We therefore shift from a “*descriptive*” to a “*behavioural*” approach (Presidenza del Consiglio dei Ministri, 2009). It is no

.....

15 The survey distribution during the emergency phase is a rather difficult operation. It is not based on an extensive reconnaissance of all the building - basic or not - subject to the earthquake but on the reporting to the respective Municipal Operational Centres or supra-municipal (DICOMAC) of survey request. This means that not necessarily in every day can be carried out surveys for example of an entire urban block. This depends on the requests, and a team could go to the same place in different days.

16 It is a form with a more than complete indication of the data needed for vulnerability analyses.

17 These instruments were already the object of analysis, tests and assessment 10 years before the tools set up for the Monumental Heritage.

longer necessary to identify the construction techniques of elements, but to understand their structural behaviour and the damage extent. This interpretation is based on the observation that regardless of materials (walls in stone or brick, grain of aggregates, type of mortar, etc.) the expected behaviours under seismic action are attributable to a limited number of responses. This is a type of survey which is not conceptually different from the task carried out for churches although it assumes different graphic form. Lastly from the identification of the data located in sections 3,4,6 and 7 the judgement of practicability and the safety measures descended accordingly.

The two protocols applied in the 1997 emergency phase were further refined and then officially adopted in 2001 (Presidenza del Consiglio dei Ministri, 2001).

It is interesting to observe that the model adopted for churches, named MODEL A - DC, edited by the Working Group for the Prevention of Cultural heritage from Natural Hazards (hereafter GLABEC)<sup>18</sup>, even if it does not modify the approach of the Genoa RU model, it makes a new step towards the simplification of the form. The form, drafted by the RU coordinated by Doglioni, was a second-level form which was not concise and practical for the emergency phase survey. The form drafted by the RU coordinated by Lagomarsino was specifically designed to be concise and easy to use even though it still was a second-level form. The form finally approved in 2001 is a first-level form instead (Fig. 14).

MODELLO A - DC Seconda sezione			
<b>A15 - RIFERIMENTO VERTICALE</b>			
Bene componente	<input type="checkbox"/> Bene individuo <input type="checkbox"/>		
<b>A16 - RIFERIMENTO SCHEDE DELLA VULNERABILITA' DELLE CHIESE</b>			
N° Scheda	_____ Data _____ Rilevatore _____		
<b>A17 - DESTINAZIONE D'USO</b>			
Parrocchia	<input type="checkbox"/> Cattedrale/Duomo <input type="checkbox"/> Santuario <input type="checkbox"/> Altro <input type="checkbox"/>		
<b>A18 - CONDIZIONI D'USO</b>			
Quotidiano	<input type="checkbox"/> Settimanale <input type="checkbox"/> Saltuario <input type="checkbox"/> Abbandonata <input type="checkbox"/> Affollamento <input type="checkbox"/>		
<b>A19 - POSIZIONE</b>			
Isolata	<input type="checkbox"/> Corpi bassi annessi <input type="checkbox"/> Estremità o angolo <input type="checkbox"/> Nel contesto urbano <input type="checkbox"/> Nel centro storico <input type="checkbox"/>		
<b>A20 - STATO DI MANUTENZIONE GENERALE</b>			
Buono	<input type="checkbox"/> Discreto <input type="checkbox"/> Scadente <input type="checkbox"/> Pessimo <input type="checkbox"/> In corso lavori <input type="checkbox"/>		
Eventuali precedenti lesioni esistenti	NO <input type="checkbox"/> SI <input type="checkbox"/> Limitate <input type="checkbox"/> Estese <input type="checkbox"/> Gravi <input type="checkbox"/>		
<b>A21 - DANNO SISMICO</b> (consultare A20 - Abaco dei meccanismi di collasso delle chiese)			
0 - □□□□ assenza di danno	1 - ■□□□ danno lieve		
3 - ■■■□□ danno medio	4 - ■■■■□□ danno grave		
	5 - ■■■■■□ crollo		
1	<b>RIBALTAMENTO DELLA FACCIATA</b> <input type="checkbox"/>		
danno	DISTACCO DELLA FACCIATA DALLE PARETI □□□□		
2	<b>MECCANISMI NELLA SOMMITÀ DELLA FACCIATA</b> <input type="checkbox"/>		
danno	LESIONI NELLA ZONA ALTA DELLA FACCIATA □□□□		
3	<b>MECCANISMI NEL PIANO DELLA FACCIATA</b> <input type="checkbox"/>		
danno	LESIONI INCLINATE (TAGLIO) - LESIONI VERTICALI O ARCuate (ROTAZIONE) □□□□		
4	<b>RISPOSTA TRASVERSALE DELL'AULA O DEL TRANSETTO</b> <input type="checkbox"/>		
danno	LESIONI NEGLI ARCONI (CON EVENTUALE PROSECUZIONE NELLA VOLTA) - ROTAZIONI, SCHIACCIAMENTI O LESIONI A TAGLIO NELLE VOLTE DELLE NAVATE LATERALI □□□□		
5	<b>RISPOSTA LONGITUDINALE DELLA NAVATA CENTRALE</b> <input type="checkbox"/>		
danno	LESIONI NEGLI ARCHI O ARCHITRAVI LONGITUDINALI - SCHIACCIAMENTI E/O LESIONI ALLA BASE DEI PILASTRI - LESIONI A TAGLIO NELLE VOLTE DELLE NAVATE LATERALI □□□□		
6	<b>VOLTE DELLA NAVATA CENTRALE</b> <input type="checkbox"/>		
danno	LESIONI NELLE VOLTE DELL'AULA CENTRALE O SCONNESSIONI DEGLI ARCONI □□□□		
7	<b>VOLTE DELLE NAVATE LATERALI E DEL TRANSETTO</b> <input type="checkbox"/>		
danno	LESIONI NELLE VOLTE O SCONNESSIONI DEGLI ARCONI □□□□		
8	<b>ARCHI TRIONFALI (DELL'AULA E DEI TRANSETTI)</b> <input type="checkbox"/>		
danno	LESIONI NELL'ARCO, SCORRIMENTO DI CONCI - SCHIACCIAMENTO ALLA BASE DEI PIEDRITTI □□□□		
9	<b>CUPOLA O TIBURIO</b> <input type="checkbox"/>		
danno	LESIONI NELLA CUPOLA, NEL TAMBURO O NELLA LANTERNA □□□□		
10	<b>RIBALTAMENTO DI ALTRE PARETI DI ESTREMITÀ (TRANSETTO, CAPPELLE)</b> <input type="checkbox"/>		
danno	DISTACCO DELLE PARETI DI ESTREMITÀ DALLE PARETI ORTOGONALI □□□□		
11	<b>RIBALTAMENTO DELL'ABSIDE (O DEL PRESBITERIO)</b> <input type="checkbox"/>		
danno	LESIONI VERTICALI O ARCuate NELLE PARETI DELL'ABSIDE □□□□		
12	<b>VOLTE DEL PRESBITERIO O DELL'ABSIDE</b> <input type="checkbox"/>		
danno	LESIONI NELLA VOLTA O NEL CATINO ABSIDALE □□□□		
13	<b>ROTTURA A TAGLIO DELLE PARETI</b> <input type="checkbox"/>		
danno	LESIONI INCLINATE (SINGOLE O INCROCIATE) - LESIONI ATTRAVERSO DISCONTINUITÀ LOCALI (VECCHIE APERTURE TAMPONATE, ECC) □□□□		
14	<b>MECCANISMI NEGLI ELEMENTI DI COPERTURA</b> <input type="checkbox"/>		
danno	LESIONI VICINE ALLE TESTE DELLE TRAVI LIGNEE, SCORRIMENTO DELLE STESSO - SCONNESSIONI TRA I CORDOLI E MURATURA - MOVIMENTI SIGNIFICATIVI DEL MANTO □□□□		
15	<b>INTERAZIONI IN PROSSIMITÀ DI IRREGOLARITÀ PLANO-ALTIMETRICHE (CORPI ADIACENTI, ARCHI RAMPANTI)</b> <input type="checkbox"/>		
danno	MOVIMENTI NEL GIUNTO O LESIONI NELLA MURATURA PER MARTELAMENTO LESIONI VERTICALI NEL CORPO MENO RIGIDO - ROTAZIONE NEL CORPO PIÙ ALTO □□□□		
16	<b>TORRE CAMPANARIA</b> <input type="checkbox"/>		
danno	LESIONI VICINO ALLO STACCO DAL CORPO DELLA CHIESA - LESIONI A TAGLIO E SCORRIMENTO LESIONI VERTICALI (ESPULSIONE DI UNO O PIÙ ANGOLI) □□□□		
17	<b>CELLA CAMPANARIA</b> <input type="checkbox"/>		
danno	LESIONI NEGLI ARCHI - ROTAZIONI O SCORRIMENTI DEI PIEDRITTI □□□□		
18	<b>AGGETTI (VELA, GUGLIE, PINNACOLI, STATUE)</b> <input type="checkbox"/>		
danno	EVIDENZA DI ROTAZIONI PERMANENTI O DI SCORRIMENTO □□□□		
<b>A22 - INDICE DI DANNO</b>			
n = □□ (numero dei meccanismi possibili) d = □□ (punteggio totale di danno) $i_d = d / 5n = □□$			
<b>A23 - AGIBILITÀ</b>			
Agibile	<input type="checkbox"/> Inagibile <input type="checkbox"/>		
Parzialmente agibile	<input type="checkbox"/> Agibile con provvedimenti <input type="checkbox"/> Temporaneamente inagibile <input type="checkbox"/> Inagibile per cause esterne <input type="checkbox"/>		
Indicare le parti agibili	Segnalare i provvedimenti anche indicandoli nella tabella sottostante		
	□ Verifica più accurata □ Si consiglia visita di esperti □ Altro		
Indicare le cause esterne			
<b>A24 - TIPO DI VISITA</b>			
Completa	<input type="checkbox"/> Parziale <input type="checkbox"/> Solo dall'esterno <input type="checkbox"/> Motivi ostativi _____		
<b>A25 - PROVVEDIMENTI DI P.I. SUGGERITI</b> (* interventi limitati ** interventi estesi)			
PROVVEDIMENTI	* **	PROVVEDIMENTI	* **
1 Revisione manto di copertura	<input type="checkbox"/> <input type="checkbox"/>	8 Ripristino smaltimento delle acque meteoriche	<input type="checkbox"/> <input type="checkbox"/>
2 Copertura provvisoria	<input type="checkbox"/> <input type="checkbox"/>	9 Monitoraggio	<input type="checkbox"/> <input type="checkbox"/>
3 Puntellamenti	<input type="checkbox"/> <input type="checkbox"/>	10 Protezioni o consolidamenti su opere d'arte fisse	<input type="checkbox"/> <input type="checkbox"/>
4 Rimozione delle macerie	<input type="checkbox"/> <input type="checkbox"/>	11 Catalogazione e smontaggio delle parti pericolanti	<input type="checkbox"/> <input type="checkbox"/>
5 Transennamenti / recinzioni / protezioni	<input type="checkbox"/> <input type="checkbox"/>	12 Sgombero opere d'arte mobili	<input type="checkbox"/> <input type="checkbox"/>
6 Consolidamenti localizzati	<input type="checkbox"/> <input type="checkbox"/>	13 Raccolta sistematica dei frammenti	<input type="checkbox"/> <input type="checkbox"/>
7 Messa in opera di cerchiatura e/o tiranti	<input type="checkbox"/> <input type="checkbox"/>	14 Ricovero e protezione dei frammenti	<input type="checkbox"/> <input type="checkbox"/>

Fig.14. Extract from A-DC Churches form approved in 2001, it is worth noting that, unlike the 1997 model, the data to be collected are essentially the possible vulnerability and the actual damage found.

18 Working Group for the Prevention of Cultural heritage from Natural Risks.

This choice probably has two supporting reasons. First of all, the estimate of 1 hour for on-site inspection and filling in the form was probably underestimated for a second-level form. Indeed, this type of form did not require the identification of the damage index only, but also of the vulnerability index. In this case, it was necessary to understand the behaviour of the macro-elements through the recognition of the lesions, as well as the identification of anti-seismic devices or further load factor. A rather detailed survey that can be carried out in such a short time only in association with a previous knowledge and identification of the useful aspects for the vulnerability assessment. Secondly, and certainly more relevant, the identification of criticality or mitigation factors can only be done after a complete survey of the building. This type of survey is not always possible in an emergency. The need for a form that could be filled in quickly and completely, and that would allow for the total operator safety, did not make the tool used in 1997 the most effective for this purpose. This has led to the subdivision of the form into two different tools, one of first-level that would identify only the average damage and the judgment of practicability in the emergency phase, and one of second-level that was designed to carry out vulnerability analysis instead. The second one, containing both damage and vulnerability indices, can be applied in the ordinary phases of heritage management in order to carry out vulnerability analysis at territorial scale (Lagomarsino, Podestà 2005).

It is also interesting to highlight how this instrument represents a summary of all the studies made up to this time:

- The seismic-structural chronology is definitively abandoned, as it is difficult to produce it in an emergency phase, but the division into macro-elements of Doglioni's RU is maintained;
- The location, crowding and conservation data of the form suggested by Gavarini and Corsanego are confirmed;
- The abacus of the main collapse mechanisms, such as the indication of practicability, prepared by Lagomarsino's RU are also included and adopted.

Between the end of the 90's and the beginning of 2000, studies on historical centres and masonry buildings continue. Also, in this case there is an effort to propose effective operational tools on a large scale, but mainly in terms of vulnerability analysis. It is the FaMIVE<sup>19</sup> case, (D'Ayala & Spence, 1995), a method that associates parameters closely related to the masonry texture and other specific factors of the historic masonry building that modify the seismic response to a series of probable collapse mechanisms (Figs. 15-16). The aim of the method is to overcome the vulnerability indices derived from the first and second-level forms of GNDT, whose estimate is linked to non-structural purposes but socio-economic or macro-seismic intensity assessment of an event. This estimate is also obtained through the simplification of the comparative historical masonry with an aseismic model not typologically and structurally congruent with the real historical building, but based on the anti-seismic normative (D'Ayala & Speranza, 1999). It is a research approach in line both with the research already carried out on historic centres (Giuffrè, 1993) and masonry buildings (Bernardini et al., 1991) and with the approach to cultural heritage of Doglioni and Lagomarsino's RUs. However, it does not propose a first or second-level form but an "intermediate level" one.

.....  
19 Failure Mechanisms Identification for Vulnerability Evaluation.

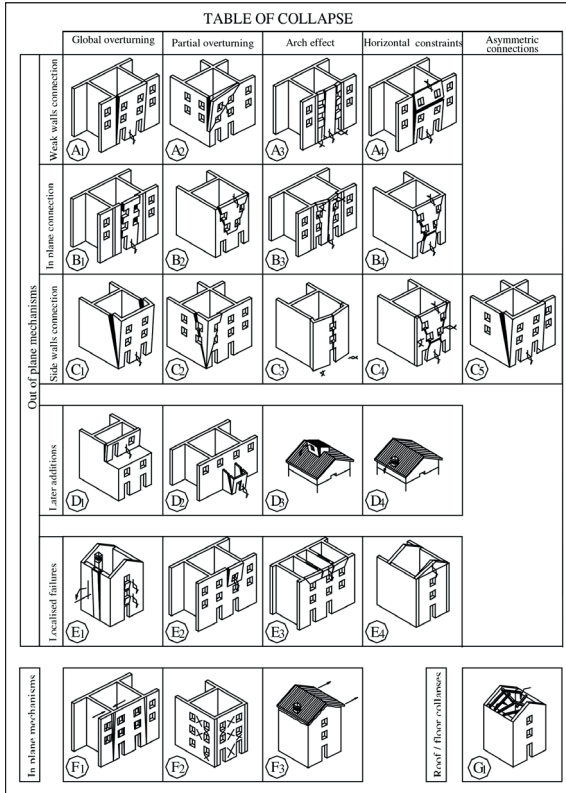

Fig.15. Abacus of collapse mechanisms identified for the FaMIVE method (D'Ayala & Speranza, 1999).

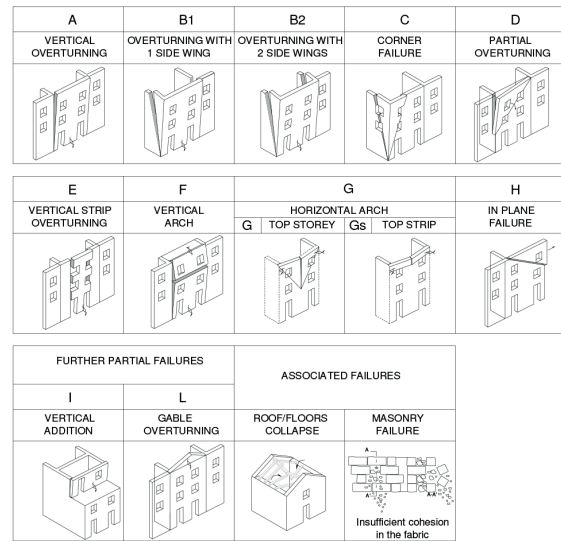

Fig.16. Evolution of collapse mechanisms abacus identified for the FaMIVE method (D'Ayala & Speranza, 2004).

The form (Fig. 17) is indeed designed to carry out a survey only from the outside of extensive areas of buildings, and can therefore be used both in the post-seismic phase and during ordinary management. It allows the surveyor to enter data on the inside only if the units are actually accessible. Such a formulation is possible through an operation, to be carried out a priori, of structural and constructive typologies identification representative of the area which provides abacuses on the average characteristics of the buildings. These are to be used for comparison when it is not possible to have an indication of internal data.

**INVESTIGATION FORM FOR THE STREET SURVEY OF ORDINARY HOUSING**

**1. General information**

Surveyor: District: Address: Cadastral ref. sheet: Block n. Type of use: n. of units

Date: Town: Map n. Particel n. Build. n. % of use: Ownership

**2. Urban position and shape of the block**

2.1 Type of urban connection

2.2 Block access and escape routes

2.3 Shape and composition of the block

2.4 Number of buildings of the block

2.5 Position within the block

2.6 Connection with adjacent buildings

2.7 Presence of slope

**3. Geometry data of the building**

3.1 Global dimension of walls

Sketch

Length: E S W N

Thickness

3.2 Presence of internal bearing walls

3.3 Number of floors

3.4 Height of building

3.5 Openings

Self openings

Other openings

Central openings

Openings slopes

**4. Structural characteristics**

4.1 Masonry quality

Plastered walls

(no plaster)

Type Dim. Lay. Sect. Mort.

Presence of diaphragms

Level of connection

Level of maintenance

Level of alteration

Synthetic judgement

4.2 Connection between walls

4.3 Out of verticality

4.4 Presence of anchors

floor E S W N

4.5 Type of roof

4.6 Level of maintenance of roof

4.7 Presence of ring beams

**5. Further vulnerability elements**

Length Height Thickn. Orient.

Vertical additions

Attics

Chimneys

Chimney/roofs

Unconcreted part

Gables

**6. Damage level and mechanisms identific.**

6.1 Damage level and mechanisms identification

SECTION A (Mechanism identification)

found E S W N

(at) (s) (st) (t) (a) (e) (n)

A1

A2

A3

A4

B1

B2

B3

B4

C1

C2

C3

C4

C5

D1

D2

D3

D4

D5

E1

E2

E3

E4

E5

F1

F2

F3

F4

F5

SECTION B (Mechanism identification not possible)

Amount found E S W N

6.2 Crack pattern descriptions

Horizontal cracks

Vertical cracks

Corner cracks

Diagonal cracks

Masonry slippage

6.3 Damage extension

floor E S W N

Sketches of crack patterns

Notes

Pictures ident. data film n. pictures n.

Fig.17. Survey sheet associated with the FaMIVE method (D'Ayala & Speranza, 1999).

It is evident that, although from a survey point of view it is a potentially quick tool, the need to identify in advance abacuses, an onerous and difficult study, has led to the tool being unsuitable for emergency operations even though it is still used in several research areas. Nevertheless, what is interesting to consider is how, starting from Giuffrè's studies, some abacuses of collapse mechanisms are being formalized also for buildings not belonging to the church type. Indeed, similarly to what was done for the FaMIVE method by Professor Dayala and Arch. Speranza, also Binda, Modena and Lagomarsino, at the end of the 90's, identify a collapse abacus for the masonry buildings of the historical centers damaged by the 1997 earthquake (Binda et al., 1999). Even in this case, it is a study that stems from the same beliefs about the GNDT methodology, which is judged to be overly simplified in order to take into account the specific features of historical buildings. It is therefore more calibrated to relatively recent constructions. Moreover, the authors believed that the macro-element concept applied to churches was not applicable to basic buildings due to their variability in plan and elevation. They also observed that it was possible to define recurring collapse mechanisms for in-plane or out-of-plane actions. The authors also remark that the method of surveying for collapse mechanisms cannot be defined as completely objective, since it is not a simple cracks measurement, but an interpretation of the structural building behaviour. Therefore, they acknowledge that the only solution to avoid the risk of bias and to allow the surveyors to reach a correct judgement is to draw up abacuses.

In 2001 the results of a further research of GNDT on the study of vulnerability in the Matese area (Molise) were published ( Regione Molise & GNDT, 2001. ). Developed by three RUs of the GNDT<sup>20</sup>, the project was aimed at studying the historic centres vulnerability of an area at high seismic risk, through successive in-depth analyses. Several survey tools are then defined to allow for the identification of the historic centres' vulnerability at different levels through the calculation methodologies set up by GNDT. The tools developed and studied for this purpose are different:

- a GENERAL FORM, not a survey form but more of a framework instrument.
- a CHECK-LIST, a tool for the census of built and environmental heritage
- a HISTORICAL CENTER FORM. This is a tool created specifically for the survey of urban vulnerability. It is structured in two parts, the first, called A, is aimed at collecting generic data on the urban structure, while the second, called B, contains parameters useful for identifying vulnerability on an urban scale.
- A QUICK FORM, depending directly on the HISTORICAL CENTER CARD, provides detailed information on the building blocks and on the single constructions in order to assess their vulnerability.
- A CHURCH FORM, having stemmed from the one studied and used in the emergency phase of the 1997 Umbria and Marche earthquake.
- A MASONRY CARD
- A DATA FORM for the recordings of potential site amplification effects.

The attention set in this study for historic buildings is still mainly focused on the vulnerability of churches. However, the broader framework within which these tools were conceived (Fig.18) makes it clear how these studies have now widened to different types. Indeed, alongside

.....  
<sup>20</sup> The RU of L'Aquila, the RU of Genoa-Rome and the local RU (Molise) supervised by Claudio Eva and Sergio Lagomarsino and, as executive manager and coordinator, Eng. Cifani.

the CHURCH FORM, an additional procedure was established, useful for vulnerability assessment. It was the STATELY BUILDING FORM ( Regione Molise, G. N. D. T., 2001: 36).

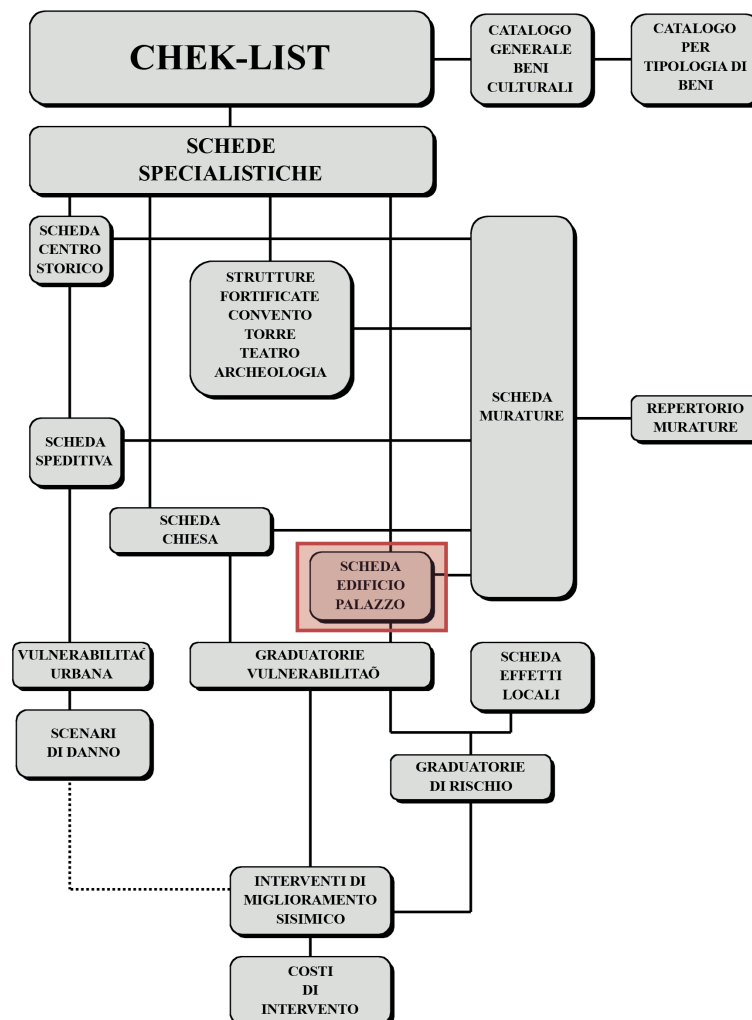

Fig.18. Block diagram of the phases and tools for the historical building survey in order to reduce the seismic risk, note how next to the church form there is a Stately Buildings forms (underlined in red)(Molise Region, G. N. D. T., 2001)

In 2002 the Molise earthquake offered a new opportunity to test and improve the damage survey tools. With regard to the form tested in 1997 by Lagomarsino, the approach for macro-elements has been confirmed and related to the new European Seismic Scale that defines 5 damage classes (Grünthal, 1998). The chance to test the methodology on further churches had also allowed for deeper validation (Lagomarsino & Podestà, 2004a; 2004b; 2004c) and highlighted the needs to modify the collapse mechanisms associated to the building type (Lagomarsino & Podestà, 2005). In 2006, the tools adopted in 2001 were re-approved, according to additional tests, with only some small changes. In particular the form “MODEL A-DC Churches” has undergone the revision of the collapse mechanisms, which have definitively risen from 18 to 28. Along with the already existing tools a new form, the form “MODEL B-DP Stately Buildings” (Presidenza del Consiglio dei Ministri, 2006), has been set up and all of these forms, which are specifically designed for cultural heritage, have also been included in the guidelines of the Ministry for Cultural heritage (hereafter MiC) (Ministero per i Beni e le Attività Culturali, 2006). The “MODEL B-DP Stately Buildings”, defined by GLABEC similarly to the previous form, “MODEL A-DC Churches”, displays an

evident reference to the abacuses that were being constructed for basic buildings (Fig. 19). It was structured through a series of experiences gained during the eruption of Etna, the Molise-Puglia earthquake of 2002, the Tuscan-Emilian Apennines earthquake in 2003, the Brescia earthquake in 2004 and during the international Civil Protection exercise “EUROSOT 2005” in Sicily ( Ministero per i Beni e le Attività Culturali, 2006).

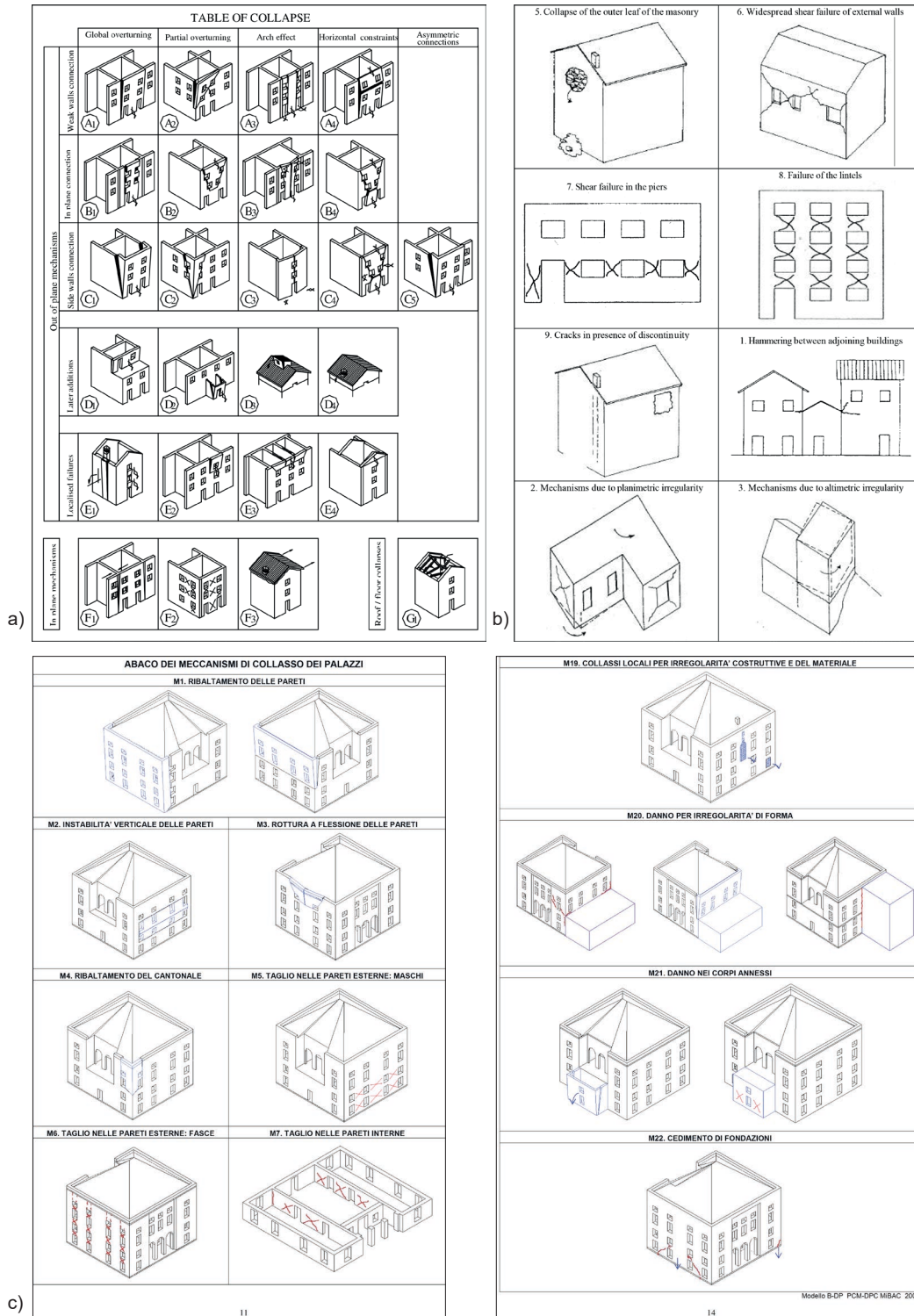

Fig.19. Abacuses developed for basic buildings and for monumental buildings compared. Note how, for example, mechanism A1 of the FaMIVE method (a) corresponds to M1 of the B-DP Stately Buildings (c) or mechanisms 7 and 8 identified by Modena, Binda and Lagomarsino (b) correspond to mechanisms M5 and M6.



However, the 2009 earthquake in Abruzzo was the moment that really put this form to the test.

The L'Aquila earthquake thus represents a new step in the debate on damage assessment tools. In particular, if the "MODEL A- DC Churches" demonstrated once again its effectiveness to such an extent that Modena and Binda defined the standardized "*substantially exempt from the subjective evaluations of the surveyor*", the "MODEL B-DP Stately Buildings" proved to be a difficult tool (Modena & Binda, 2009), since its first application. From 2009 until today, there have been progressive improvements to the forms for the survey of basic buildings<sup>21</sup>. However, studies on the forms for those cultural assets which are different from the church typology seem to have been halted. The planned "*further improvements*" (Modena & Binda, 2009) which were additionally requested by the officials of the Ministry who are the same subjects that were in charge of the cultural heritage survey, have never been achieved. Contrary to what happened to the other tools that have had a gradual but progressive improvement towards the characters of simplicity and quickness, which were recommended by Lagomarsino, the "MODEL B-DP Stately Buildings" has not undergone any change and is still used to the detriment of the tool's effectiveness.

Since 2006, the studies for Architectural Heritage seem to have halted, while those for basic buildings have not only continued with the subsequent improvement of the AeDES form but are also trying to go beyond it. In the 2000s the increasing number of buildings to be surveyed has brought to the need to create tools not only useful in the emergency phase, but also to increase awareness and assist the surveyors in understanding the behaviour of buildings and in particular that of masonry buildings. The project for the development of "MEDEA, Manuale Di Esercitazioni sul Danno Ed Agibilità"<sup>22</sup>, was oriented towards this aim (Zuccaro & Papa, 2003). It is a guide that is offered as a multimedia tool for the training of professionals qualified to the damage survey and the practicability assessment. Through a guided process by successive steps, MEDEA increases the sensitivity in the analysis and structural interpretation (Zuccaro, 2004). Among the main aims, in addition to professional training, is the manual which endeavours to be a tool to improve the uniformity of survey data, as well as a tool to go beyond the current, and still operational, tools for the practicability assessment.

In recent years, then, the succession of short-distance events (Molise 2002, Abruzzo 2009, Emilia 2012, Central Italy 2016) has shifted the centre of the debate from the level of individual buildings to that of the territorial and urban scale. In this historic moment there is the urge to direct urban planning policies towards a more conscious seismicity of sites. The purpose is no longer lonely the emergency management, but the identification of the requirements for the ordinary urban activities restarting after the seismic events, already in the planning process. It is a very relevant issue especially in Emilia-Romagna that has seen the depopulation of some towns. The first activities in this direction have been developed within the project UrbiSIT (Cavinato, 2013) whose objective was the creation of a Geographic Information System of the geological and technical surface and subsurface characteristics of urban areas. The goal was the realization of geological and technical models aimed at seismic micro-zonation. A particular issue of this project concerned the investigation of

.....

<sup>21</sup> Over time, there have been several models of Aedes forms: 05/2000, 06/2008 and 07/2013. This last model, with its manual, was then re-approved with the DPCM of July 8, 2014.

<sup>22</sup> Damage and Practicability Judgment Exercise Guide.

the Limit Conditions of urban settlement. In analogy with the limit states prescribed by the regulations for buildings, these represented different and increasing levels in loss of functionality in Urban settlements (Fig. 20).

condizioni limite / sistemi urbani	funzioni strategiche emergenza	funzioni strategiche	funzioni urbane	residenza	
CLO	==	==	==	==	==
CLD	==	==	==	==	==
CLV	==	==	==	—	—
CLC	==	==	—	✗	✗
CLE	==	✗	✗	✗	✗

==

==

—

✗

✗

mantenimento

limitazione temporanea

limitazione parziale

interruzione sensibile

interruzione a lungo termine

Fig.20. Identification of limit conditions of urban systems in relation to progressive function disruption (Bramerini et al., 2013).

The last of the identified states was that of the emergency limit condition. It represents the final condition of urban organisms which once exceeded would no longer allow either reactivation of urban functions or emergency management. From an objective-oriented point of view, this condition represents a “*minimum aim*” (Bramerini et al., 2013) to be reached through appropriate seismic risk mitigation interventions that ensure this threshold is not exceeded. As a result of this study, the analysis of the Emergency Limit Condition (hereafter CLE), and the reference forms to achieve it, have been introduced in the Italian system with OPCM 3907/2010. The CLE analysis today represents a first regulatory point for the understanding of vulnerability at the urban scale and its inclusion within urban planning policies (Fig. 21). However, it can be seen more as an interpreting tool than a design tool.

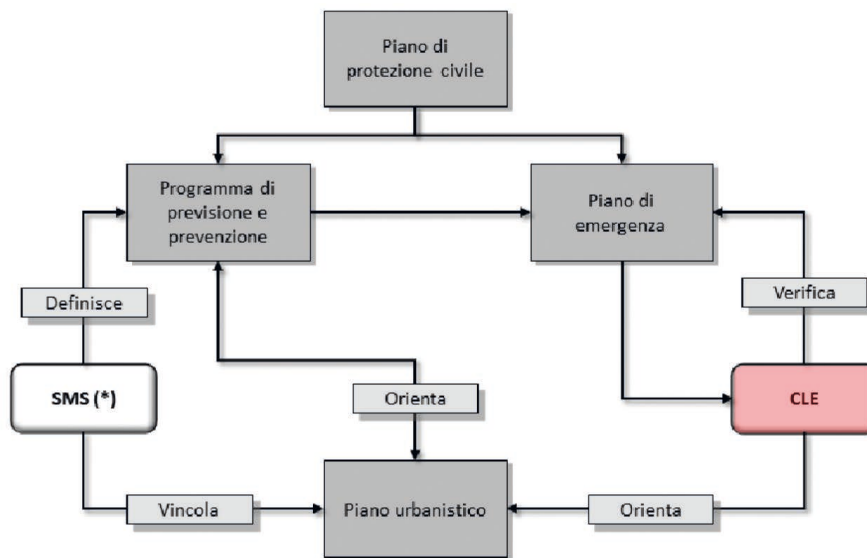

Fig.21. Ideal placement of the CLE tool within urban planning (Bramerini et al., 2013).

Other analyses and research are still in progress both on the urban planning level and on that of extensive data collection for buildings. We can mention, for example, the studies for

the identification of the Minimum Urban Structure (SUM) (Olivieri, 2013; Fabietti, 2013)<sup>23</sup>, defined as the minimum resistant urban structure, i.e., able to resist even after a calamitous event.

Regarding the survey campaigns for the vulnerability assessment of basic buildings on a large scale, a new tool for urban nuclei, the CARTIS, is being tested and progressively implemented.

Developed as part of the three-year Project ReLUIIS 2014-2016 carried out by the consortium “Network of Earthquake Engineering University Laboratories” and funded by the Department of Civil Protection (DPC), the CARTIS form is aimed at surveying the basic building types predominant within the urban districts and city neighbourhoods. The premise is that this should have been characterized by uniformity of age and / or construction and structural techniques in the building tissue. It is worth recalling here the studies carried out for the creation of the FAMIVE method which established the basis for this new tool.

The first procedure executed, that would allow for the survey of building features, was carried out through the use of an interview protocol (Dolce et al., 2002 ) to be proposed to local technicians. This methodology persists within the new tool. Indeed, it allows technicians from other regions to have a prompt and effective understanding of the local building characteristics through knowledge transfer between the local technicians and the surveyors themselves. The final goal of this survey would be conducting data collection that allows for, on the one hand, the vulnerability assessments through any validated methodology and, on the other hand, the construction of fragility curves on a regional scale, i.e., more adherent to the typological-constructive characteristics of the different Italian areas (Zuccaro et al., 2015).

Similarly to the forms implemented for cultural heritage, this tool requires the “*critical spirit*” of the surveyor who must acquire the data but at the same time he should verify its accuracy (Zuccaro et al., 2015).

A process that started in 2002 with the drafting of the first interview protocol, the form, is still being tested on site, although it was proposed and applied on several studies. The long validation phase which the tool has undergone up to today is a clear sign of how the experience gained in the field of damage and vulnerability surveying has been capitalized.

The collection of non-exhaustive and targeted data, especially in the emergency phase, must in fact be supported by tools that easily guide the surveyors to accomplish the right decisions. The progressive and gradual development of tools for MODEL A-DC Churches or AeDES form is in fact the evidence of how these protocols must necessarily be the result of numerous “rethinks”, improvements and tests so that they are transformed from studies and research to real operational and operating models.

.....  
23 Commonly called SUM.

## 1.3 Current operating tools for damage and vulnerability assessment

- **AeDES Form**

While studies for second-level analyses are still a highly active research area, from a damage analysis point of view the process for surveying basic buildings seems to have come to a conclusion with the publication of the updated “*Model for damage survey, emergency response and practicability for basic buildings in the post-seismic emergency*”, better known as the AeDES form, and its subsequent manual in 2014 (Presidenza del Consiglio dei Ministri, 2009).

As previously outlined, the form goes beyond the descriptive approach of basic building construction to a behavioural approach. In this case different building construction techniques are clustered according to their expected behaviour under seismic action. An initial and crucial point of the survey from the AeDES form is the proper identification of the building unit, defined as a homogeneous unit distinguishable from adjacent buildings through parameters such as type of construction, difference in height, age of construction, presence of staggered floors, and more. Once the recognition, which is not always easy, has been carried out one can start the survey of the “building”. The form is made up of 9 sections to be filled in through multi-choice or single-choice boxes to be marked. For all the damage survey forms, including therefore also the “MODEL A-DC Churches” and the “MODEL B-DP Stately Buildings”, the distinction between the two possibilities is unequivocally identified through the circular box for the single choice or the rectangular box for the multi-choice criteria. The use of grey boxes has been adopted for the identification of data that must not be provided during the survey campaign as a conventional statement for all forms.

- Section 1 - building identification. This section provides for the localization data input such as Province, Municipality, Suburb and Street, the map of the structural block and the building identification as well as the data concerning the survey team and the form identifier. There is also a section to be filled in by the office requesting the ISTAT data necessary for the building identification.
- Section 2 - building description. This section identifies the metric parameters, the age of construction and time of last renovation, as well as data regarding use and exposure.
- Section 3 - typology. In this section the main constructive characteristics of the building are defined in relation to the type of structural behaviour they have.
- Section 4 - damage to structural elements and emergency measures (P.I.) executed. This section requires the assessment of the damage type and its entity for each structural category (vertical structures, horizontal structures, stairs...). The necessary emergency measures should also be indicated.
- Section 5 - damage to non-structural elements and emergency measures (P.I.) executed. In this section, similarly to the previous one, damage to non-structural elements is identified. In this case it is not required to identify degree and entity, but only the presence of damage itself. Even in this case it is possible to suggest measures of emergency response.

- Section 6 - exogenous danger induced by other buildings, networks, slopes and emergency measures (P.I.) executed. In this section it is indicated if the building is to be considered in danger not for its own decay but for the presence of external hazards.
- Section 7 - soil and foundations. This section identifies the morphology of the ground and any foundation instability.
- Section 8 - judgment of practicability. This is the section intended for the practicability evaluation of the building. The judgment must be made taking into consideration the type of risk deriving from the different previously filled in sections (sections 3,4,5,6,7).
- Section 9 - Other observations

An empty model of the instrument below:

ID SCHEDA: \_\_\_\_\_

**SEZIONE 1 - IDENTIFICAZIONE EDIFICIO**

Provincia: \_\_\_\_\_  
Comune: \_\_\_\_\_  
Frazione/Località:  
(denominazione Istat)  
1  VIA \_\_\_\_\_  
2  CORSO \_\_\_\_\_  
3  VICOLO \_\_\_\_\_ Num. Civici \_\_\_\_\_  
4  PIAZZA \_\_\_\_\_  
5  ALTRO \_\_\_\_\_  
(Indicare contrada, località, traversa, salita, etc.)

COORDINATE  piane UTM  geografiche  altro \_\_\_\_\_

Fuso (32-33-34) ____	Datum <input type="radio"/> ED50 <input type="radio"/> WGS84	Nord/Lat _____ Est/Long _____
----------------------------	--	--

IDENTIFICATIVO SOPRALLUOGO  
Squadra \_\_\_\_\_ Scheda n. \_\_\_\_\_ Data \_\_\_\_\_  
giorno | mese | anno |

IDENTIFICATIVO EDIFICIO  
Istat Reg. \_\_\_\_\_ Istat Prov. \_\_\_\_\_ Istat Comune \_\_\_\_\_  
N° aggregato \_\_\_\_\_ N° edificio \_\_\_\_\_

Cod. di Località Istat Sez. di censimento Istat	_____ _____	Tipo carta N° carta	_____ _____
--	----------------	------------------------	----------------

Dati catastali Foglio \_\_\_\_\_ Allegato \_\_\_\_\_  
Particelle \_\_\_\_\_

Posizione edificio  Isolato  Interno  D'estremità  D'angolo

DENOMINAZIONE EDIFICIO O PROPRIETARIO \_\_\_\_\_  
\_\_\_\_\_  
\_\_\_\_\_

**Codice Uso**  
IS \_\_\_\_\_

MAPPA DELL'AGGREGATO STRUTTURALE CON IDENTIFICAZIONE DELL'EDIFICIO



**SEZIONE 2 - DESCRIZIONE EDIFICIO**

Dati metrici				Età (max 2)		Uso - esposizione			
N° Piani totali con interrati	Altezza media di piano [m]	Superficie media di piano [m <sup>2</sup> ]		Costr. e ristr.		Uso	N° unità d'uso	Utilizzazione	Occupanti
<input type="radio"/> 1 <input type="radio"/> 9	1 <input type="radio"/> < 2.50	A <input type="radio"/> < 50	I <input type="radio"/> 400 ÷ 499	1 <input type="checkbox"/> < 1919	A <input type="checkbox"/> Abitativo	_____	_____	A <input type="radio"/> > 65%	_____
<input type="radio"/> 2 <input type="radio"/> 10	2 <input type="radio"/> 2.50 ÷ 3.49	B <input type="radio"/> 50 ÷ 69	L <input type="radio"/> 500 ÷ 649	2 <input type="checkbox"/> 19 ÷ 45	B <input type="checkbox"/> Produttivo	_____	_____	B <input type="radio"/> 30 ÷ 65%	_____
<input type="radio"/> 3 <input type="radio"/> 11	3 <input type="radio"/> 3.50 ÷ 5.00	C <input type="radio"/> 70 ÷ 99	M <input type="radio"/> 650 ÷ 899	3 <input type="checkbox"/> 46 ÷ 61	C <input type="checkbox"/> Commercio	_____	_____	C <input type="radio"/> < 30%	_____
<input type="radio"/> 4 <input type="radio"/> 12	4 <input type="radio"/> > 5.00	D <input type="radio"/> 100 ÷ 129	N <input type="radio"/> 900 ÷ 1199	4 <input type="checkbox"/> 62 ÷ 71	D <input type="checkbox"/> Uffici	_____	_____	D <input type="radio"/> Non utilizz.	_____
<input type="radio"/> 5 <input type="radio"/> >12		E <input type="radio"/> 130 ÷ 169	O <input type="radio"/> 1200 ÷ 1599	5 <input type="checkbox"/> 72 ÷ 75	E <input type="checkbox"/> Serv. Pubbl.	_____	_____	E <input type="radio"/> In costruz.	_____
<input type="radio"/> 6	Piani interrati A <input type="radio"/> 0 C <input type="radio"/> 2 B <input type="radio"/> 1 D <input type="radio"/> ≥3	F <input type="radio"/> 170 ÷ 229	P <input type="radio"/> 1600 ÷ 2199	6 <input type="checkbox"/> 76 ÷ 81	F <input type="checkbox"/> Deposito	_____	_____	F <input type="radio"/> Non finito	_____
<input type="radio"/> 7		G <input type="radio"/> 230 ÷ 299	Q <input type="radio"/> 2200 ÷ 3000	7 <input type="checkbox"/> 82 ÷ 86	G <input type="checkbox"/> Strategico	_____	_____	G <input type="radio"/> Abbandon.	_____
<input type="radio"/> 8		H <input type="radio"/> 300 ÷ 399	R <input type="radio"/> > 3000	8 <input type="checkbox"/> 87 ÷ 91	H <input type="checkbox"/> Turist-ricett.	_____	_____		
				9 <input type="checkbox"/> 92 ÷ 96					
				10 <input type="checkbox"/> 97 ÷ 01					
				11 <input type="checkbox"/> 02 ÷ 08					
				12 <input type="checkbox"/> 09 ÷ 11					
				13 <input type="checkbox"/> > 2011					
						Proprietà A <input type="checkbox"/> Pubblica B <input type="checkbox"/> Privata _____% _____%			

Istat Provincia  Istat Comune  Squadra  N° scheda  Data

**SEZIONE 3 - TIPOLOGIA** (multiscelta; per gli edifici in muratura indicare al massimo 2 tipi di combinazioni strutture verticali-solai)

Strutture verticali Strutture orizzontali		STRUTTURE IN MURATURA						ALTRE STRUTTURE			
		Non identificate	A tessitura irregolare e di cattiva qualità (Pietrame non squadrato, ciottoli,...)		A tessitura regolare e di buona qualità (Blocchi; mattoni; pietra squadrata,...)		Piastrini isolati	Mista	Rinforzata	1 Telai in c.a.	
			Senza catene o cordoli	Con catene o cordoli	Senza catene o cordoli	Con catene o cordoli				2 Pareti in c.a.	3 Telai in acciaio
A	B	C	D	E	F	G	H	REGOLARITÀ	Non Regolare A	Regolare B	
1	Non identificate	<input type="radio"/>	<input type="checkbox"/>	<input type="checkbox"/>	<input type="checkbox"/>	<input type="checkbox"/>	<input type="checkbox"/>	<input type="checkbox"/>	<input type="checkbox"/>	<input type="checkbox"/>	<input type="checkbox"/>
2	Volte senza catene	<input type="checkbox"/>	<input type="checkbox"/>	<input type="checkbox"/>	<input type="checkbox"/>	<input type="checkbox"/>	<input type="checkbox"/>	<input type="checkbox"/>	<input type="checkbox"/>	<input type="checkbox"/>	<input type="checkbox"/>
3	Volte con catene	<input type="checkbox"/>	<input type="checkbox"/>	<input type="checkbox"/>	<input type="checkbox"/>	<input type="checkbox"/>	<input type="checkbox"/>	<input type="checkbox"/>	<input type="checkbox"/>	<input type="checkbox"/>	<input type="checkbox"/>
4	Travi con soletta deformabile (travi in legno con semplice tavolato, travi e volte,...)	<input type="checkbox"/>	<input type="checkbox"/>	<input type="checkbox"/>	<input type="checkbox"/>	<input type="checkbox"/>	<input type="checkbox"/>	<input type="checkbox"/>	NO	<input type="checkbox"/>	<input type="checkbox"/>
5	Travi con soletta semirigida (travi in legno con doppio tavolato, travi e tavelloni,...)	<input type="checkbox"/>	<input type="checkbox"/>	<input type="checkbox"/>	<input type="checkbox"/>	<input type="checkbox"/>	<input type="checkbox"/>	<input type="checkbox"/>	<input type="checkbox"/>	<input type="checkbox"/>	<input type="checkbox"/>
6	Travi con soletta rigida (solai di c.a., travi ben collegate a solette di c.a.,...)	<input type="checkbox"/>	<input type="checkbox"/>	<input type="checkbox"/>	<input type="checkbox"/>	<input type="checkbox"/>	<input type="checkbox"/>	<input type="checkbox"/>	<input type="checkbox"/>	<input type="checkbox"/>	<input type="checkbox"/>

COPERTURA		
1	<input type="radio"/> Spingente pesante	
2	<input type="radio"/> Non spingente pesante	
3	<input type="radio"/> Spingente leggera	
4	<input type="radio"/> Non spingente leggera	

**SEZIONE 4 - DANNI AD ELEMENTI STRUTTURALI e provvedimenti di pronto intervento (P.I.) eseguiti**

Livello-estensione Componente strutturale-Danno preesistente		Danno <sup>(1)</sup>									Provvedimenti di P.I. eseguiti						
		D4 - D5 Gravissimo			D2 - D3 Medio Grave			D1 Leggero			Nullo	Nessuno	Demolizioni	Cercature e/o tiranti	Riparazione	Puntelli	Trasenne e protezione passaggi
		> 2/3	1/3 - 2/3	< 1/3	> 2/3	1/3 - 2/3	< 1/3	> 2/3	1/3 - 2/3	< 1/3							
1	Strutture verticali	<input type="checkbox"/>	<input type="checkbox"/>	<input type="checkbox"/>	<input type="checkbox"/>	<input type="checkbox"/>	<input type="checkbox"/>	<input type="checkbox"/>	<input type="checkbox"/>	<input type="checkbox"/>	<input type="checkbox"/>	<input type="checkbox"/>	<input type="checkbox"/>	<input type="checkbox"/>	<input type="checkbox"/>	<input type="checkbox"/>	<input type="checkbox"/>
2	Solai	<input type="checkbox"/>	<input type="checkbox"/>	<input type="checkbox"/>	<input type="checkbox"/>	<input type="checkbox"/>	<input type="checkbox"/>	<input type="checkbox"/>	<input type="checkbox"/>	<input type="checkbox"/>	<input type="checkbox"/>	<input type="checkbox"/>	<input type="checkbox"/>	<input type="checkbox"/>	<input type="checkbox"/>	<input type="checkbox"/>	<input type="checkbox"/>
3	Scale	<input type="checkbox"/>	<input type="checkbox"/>	<input type="checkbox"/>	<input type="checkbox"/>	<input type="checkbox"/>	<input type="checkbox"/>	<input type="checkbox"/>	<input type="checkbox"/>	<input type="checkbox"/>	<input type="checkbox"/>	<input type="checkbox"/>	<input type="checkbox"/>	<input type="checkbox"/>	<input type="checkbox"/>	<input type="checkbox"/>	<input type="checkbox"/>
4	Copertura	<input type="checkbox"/>	<input type="checkbox"/>	<input type="checkbox"/>	<input type="checkbox"/>	<input type="checkbox"/>	<input type="checkbox"/>	<input type="checkbox"/>	<input type="checkbox"/>	<input type="checkbox"/>	<input type="checkbox"/>	<input type="checkbox"/>	<input type="checkbox"/>	<input type="checkbox"/>	<input type="checkbox"/>	<input type="checkbox"/>	<input type="checkbox"/>
5	Tamponature - Tramezzi	<input type="checkbox"/>	<input type="checkbox"/>	<input type="checkbox"/>	<input type="checkbox"/>	<input type="checkbox"/>	<input type="checkbox"/>	<input type="checkbox"/>	<input type="checkbox"/>	<input type="checkbox"/>	<input type="checkbox"/>	<input type="checkbox"/>	<input type="checkbox"/>	<input type="checkbox"/>	<input type="checkbox"/>	<input type="checkbox"/>	<input type="checkbox"/>
6	Danno preesistente	<input type="checkbox"/>	<input type="checkbox"/>	<input type="checkbox"/>	<input type="checkbox"/>	<input type="checkbox"/>	<input type="checkbox"/>	<input type="checkbox"/>	<input type="checkbox"/>	<input type="checkbox"/>	<input type="checkbox"/>	<input type="checkbox"/>	<input type="checkbox"/>	<input type="checkbox"/>	<input type="checkbox"/>	<input type="checkbox"/>	<input type="checkbox"/>

(1) - Di ogni livello di danno indicare l'estensione solo se esso è presente. Se l'oggetto indicato nella riga non è danneggiato, campire Nullo.

**SEZIONE 5 - DANNI AD ELEMENTI NON STRUTTURALI e provvedimenti di pronto intervento (P.I.) eseguiti**

Tipo di danno	Presenza Danno	Provvedimenti di P.I. eseguiti					
		Nessuno	Rimozione	Puntelli	Riparazione	Divieto di accesso	Trasenne e protezione passaggi
	A	B	C	D	E	F	G
1	Distacco intonaci, rivestimenti, controsoffitti, ...	<input type="checkbox"/>	<input type="checkbox"/>	<input type="checkbox"/>	<input type="checkbox"/>	<input type="checkbox"/>	<input type="checkbox"/>
2	Caduta tegole, comignoli, canne fumarie, ...	<input type="checkbox"/>	<input type="checkbox"/>	<input type="checkbox"/>	<input type="checkbox"/>	<input type="checkbox"/>	<input type="checkbox"/>
3	Caduta cornicioni, parapetti, ...	<input type="checkbox"/>	<input type="checkbox"/>	<input type="checkbox"/>	<input type="checkbox"/>	<input type="checkbox"/>	<input type="checkbox"/>
4	Caduta altri oggetti interni o esterni	<input type="checkbox"/>	<input type="checkbox"/>	<input type="checkbox"/>	<input type="checkbox"/>	<input type="checkbox"/>	<input type="checkbox"/>
5	Danno alla rete idrica, fognaria o termoidraulica	<input type="checkbox"/>	<input type="checkbox"/>	<input type="checkbox"/>	<input type="checkbox"/>	<input type="checkbox"/>	<input type="checkbox"/>
6	Danno alla rete elettrica o del gas	<input type="checkbox"/>	<input type="checkbox"/>	<input type="checkbox"/>	<input type="checkbox"/>	<input type="checkbox"/>	<input type="checkbox"/>

**SEZIONE 6 - Pericolo ESTERNO indotto da altre costruzioni, reti, versanti e provvedimenti di pronto intervento (P.I.) eseguiti**

Causa	Pericolo su:				Provvedimenti di P.I. eseguiti		
	Assente	Edificio	Vie d'accesso o di fuga	Vie interne	Nessuno	Divieto di accesso	Barriere protettive
1	Crolli o caduta oggetti da edifici adiacenti	<input type="checkbox"/>	<input type="checkbox"/>	<input type="checkbox"/>	<input type="checkbox"/>	<input type="checkbox"/>	<input type="checkbox"/>
2	Collasso di reti di distribuzione	<input type="checkbox"/>	<input type="checkbox"/>	<input type="checkbox"/>	<input type="checkbox"/>	<input type="checkbox"/>	<input type="checkbox"/>
3	Crolli da versanti incombenti	<input type="checkbox"/>	<input type="checkbox"/>	<input type="checkbox"/>	<input type="checkbox"/>	<input type="checkbox"/>	<input type="checkbox"/>

**SEZIONE 7 - TERRENO E FONDAZIONI**

Morfologia del sito				Dissesti alle fondazioni			
1 <input type="radio"/> Cresta	2 <input type="radio"/> Pendio forte	3 <input type="radio"/> Pendio leggero	4 <input type="radio"/> Pianura	A <input type="radio"/> Assenti	B <input type="radio"/> Generati dal sisma	C <input type="radio"/> Acuiti dal sisma	D <input type="radio"/> Preesistenti

Istat Provincia     Istat Comune     Squadra     N° scheda     Data

### SEZIONE 8 - Giudizio di agibilità

8-A Valutazione del rischio					8-B Esito di agibilità	
Rischio	Esterno (sez. 6)	Strutturale (sez. 3 e 4)	Non Strutturale (sez. 5)	Geotecnico (sez. 7)	A	
Basso	<input type="radio"/>	<input type="radio"/>	<input type="radio"/>	<input type="radio"/>	Edificio AGIBILE (*)	<input type="radio"/>
Basso con provvedimenti	<input type="radio"/>	<input type="radio"/>	<input type="radio"/>	<input type="radio"/>	Edificio TEMPORANEAMENTE INAGIBILE (in tutto o in parte) ma AGIBILE con provvedimenti di P.I. (1)	<input type="radio"/>
Alto	<input type="radio"/>	<input type="radio"/>	<input type="radio"/>	<input type="radio"/>	Edificio PARZIALMENTE INAGIBILE (2)	<input type="radio"/>
					Edificio TEMPORANEAMENTE INAGIBILE da rivedere con approfondimento (3)	<input type="radio"/>
					Edificio INAGIBILE (4)	<input type="radio"/>
					Edificio INAGIBILE per rischio esterno (5)	<input type="checkbox"/>

(\*) La compilazione della presente scheda non costituisce una verifica sismica né sostituisce il rispetto degli obblighi relativi alla sicurezza sui luoghi di lavoro ai sensi delle normative vigenti.

**NOTE:** (1) Esito B nelle note (Sez.9) riportare se la temporanea inagibilità è totale o parziale e, in quest'ultimo caso, quali sono le parti inagibili e proporre in Sez. 8D i necessari provvedimenti di pronto intervento che possono rimuovere l'inagibilità (da indicare anche nel modulo GP1)  
 (2) Esito C nelle note (Sez.9) specificare chiaramente quali sono le parti inagibili (in maniera descrittiva e/o grafica) e proporre in Sez. 8D eventuali provvedimenti di pronto intervento necessari per la sicurezza esterna (da indicare anche nel modulo GP1).  
 (3) Esito D nelle note (Sez.9) specificare motivazioni e tipo di approfondimento qui richiesto \_\_\_\_\_ e proporre in Sez. 8D eventuali provvedimenti di pronto intervento necessari per la sicurezza esterna (da indicare anche nel modulo GP1).  
 (4) Esito E proporre in Sez. 8D eventuali provvedimenti di pronto intervento necessari per la sicurezza esterna (da indicare anche nel modulo GP1).  
 (5) Esito F nelle note (Sez.9) specificare quali sono le cause di rischio esterno e proporre in Sez. 8D eventuali interventi di pronto intervento necessari per la sicurezza esterna (da indicare anche nel modulo GP1).

<b>8-C Sull'accuratezza della visita</b>	1 <input type="radio"/> Solo dall'esterno	4 <input type="radio"/> Non eseguito per:	A <input type="radio"/> Sopralluogo rifiutato (SR)	B <input type="radio"/> Rudere (RU)	C <input type="radio"/> Demolito (DM)
	2 <input type="radio"/> Parziale		D <input type="radio"/> Proprietario non trovato (NT)	E <input type="radio"/> Altro (AL) _____	
	3 <input type="radio"/> Completa (>2/3)				

### 8-D Provvedimenti suggeriti di pronto intervento di rapida realizzazione, limitati (\*) o estesi (\*\*)

*	**	PROVVEDIMENTI DI P.I. SUGGERITI	*	**	PROVVEDIMENTI DI P.I. SUGGERITI
1 <input type="checkbox"/>	<input type="checkbox"/>	Messa in opera di cerchiature o tiranti	7 <input type="checkbox"/>	<input type="checkbox"/>	Rimozione di cornicioni, parapetti, aggetti, ...
2 <input type="checkbox"/>	<input type="checkbox"/>	Riparazione danni leggeri alle tamponature e tramezzi	8 <input type="checkbox"/>	<input type="checkbox"/>	Rimozione di altri oggetti interni o esterni
3 <input type="checkbox"/>	<input type="checkbox"/>	Riparazione copertura	9 <input type="checkbox"/>	<input type="checkbox"/>	Transennature e protezione passaggi
4 <input type="checkbox"/>	<input type="checkbox"/>	Puntellatura di scale	10 <input type="checkbox"/>	<input type="checkbox"/>	Riparazioni delle reti degli impianti
5 <input type="checkbox"/>	<input type="checkbox"/>	Rimozione di intonaci, rivestimenti, controsottature, ...	11 <input type="checkbox"/>	<input type="checkbox"/>	
6 <input type="checkbox"/>	<input type="checkbox"/>	Rimozione di tegole, comignoli, canne fumarie, ...	12 <input type="checkbox"/>	<input type="checkbox"/>	

### 8-E Unità immobiliari inagibili, famiglie e persone evacuate

Unità immobiliari inagibili     Nuclei familiari evacuati     N° persone evacuate

### SEZIONE 9 - Altre osservazioni

Sul danno, sui provvedimenti di pronto intervento, l'agibilità o altro	ARGOMENTO	ANNOTAZIONI	Foto d'insieme dell'edificio	Spilla
<div style="border: 1px solid black; height: 150px;"></div>				

I componenti della squadra di ispezione (stampatello)

Firme

\_\_\_\_\_



## NOTE ESPLICATIVE SULLA COMPILAZIONE DELLA SCHEDA AeDES 07/2013

La scheda va compilata per un intero edificio intendendo per edificio una unità strutturale "cielo terra", individuabile per caratteristiche tipologiche e quindi distinguibile dagli edifici adiacenti per tali caratteristiche e anche per differenza di altezza e/o età di costruzione e/o piani sfalsati, etc..

La scheda è divisa in 9 sezioni. Le informazioni sono generalmente definite annerendo le caselle corrispondenti; in alcune sezioni la presenza di caselle quadrate (□) indica la possibilità di **multiscelta**: in questi casi si possono fornire più indicazioni; le caselle tonde (○) indicano la possibilità di una singola scelta. Dove sono presenti le caselle [ ] si deve scrivere in stampatello appoggiando il testo a sinistra ed i numeri a destra.

### Sezione 1 - Identificazione edificio

Indicare i dati di localizzazione: Provincia, Comune e Frazione.

#### IDENTIFICATIVO SOPRALLUOGO

La squadra riporta il proprio numero assegnato dal coordinamento centrale, un numero progressivo di scheda e la data del sopralluogo.

#### IDENTIFICATIVO EDIFICIO

L'organizzazione del rilevamento prevede un Coordinamento Tecnico e la collaborazione dell'ufficio tecnico comunale. Questo ha tra l'altro il compito di assistenza per l'espletamento del lavoro dei rilevatori e per l'individuazione degli edifici. L'edificio in generale non è pre-individuato ed è quindi compito del rilevatore il suo riconoscimento e la sua identificazione sulla cartografia riportata nello spazio della prima facciata. Il codice identificativo dell'edificio, costituito dall'insieme dei dati della prima riga nello spazio in grigio, viene poi assegnato, in modo univoco, presso il coordinamento comunale dove i rilevatori, dopo la visita comunicano l'esito del sopralluogo. La numerazione degli aggregati e degli edifici deve essere tenuta aggiornata in una cartografia generale presso il coordinamento comunale in modo che i rilevatori possano riferire le visite di sopralluogo, che sono richieste in genere su unità immobiliari, all'edificio che effettivamente le contiene. Per l'identificativo, il n° di carta, i dati Istat e i dati catastali è necessario quindi avvalersi della collaborazione del coordinamento comunale.

**POSIZIONE EDIFICIO:** se l'edificio non è isolato su tutti i lati, va indicata la sua posizione all'interno dell'aggregato (Interno, d'estremità, angolo). **DENOMINAZIONE EDIFICIO O PROPRIETARIO:** indicare la denominazione se edificio pubblico o il nome del condominio o di uno o più dei proprietari se privato (es.: Condominio Verde, Rossi Mario). **COORDINATE:** Specificare se trattasi di coordinate piane N/E (U.T.M., metri) o geografiche Lat./Long. (gradi), il Fuso (32, 33, 34), il Datum (ED50 o WGS84). Se si usa un altro riferimento, specificare in *altra*.

### Sezione 2 - Descrizione edificio

**N° PIANI TOTALI CON INTERRATI:** indicare il numero di piani complessivi dell'edificio dallo spiccatto di fondazioni incluso quello di sottotetto (se esistente e solo se praticabile ossia consistente in un solaio efficace). Computare interrati i piani mediamente interrati per più di metà della loro altezza. **ALTEZZA MEDIA DI PIANO:** indicare l'altezza che meglio approssima la media delle altezze di piano presenti. **SUPERFICIE MEDIA DI PIANO:** va indicato l'intervallo che comprende la media delle superfici di tutti i piani. **ETA (2 OPZIONI):** è possibile fornire 2 indicazioni: la prima è sempre l'età di costruzione, la seconda è l'eventuale anno in cui si sono effettuati eventuali interventi sulle strutture. **USO (MULTISCHELT):** indicare i tipi di uso compresenti nell'edificio. **UTILIZZAZIONE:** l'indicazione "abbandonato" si riferisce al caso di "non utilizzato in cattive condizioni".

### Sezione 3 - Tipologia ( massimo 2 opzioni)

Per gli edifici in muratura si possono segnalare le due combinazioni: strutture orizzontali e verticali prevalenti o più vulnerabili; ad esempio: volte senza catene e muratura in pietrame al 1° livello (2B) e solai rigidi (in c.a.) e muratura in pietrame al 2° livello (6B). La muratura è distinta in due tipi in ragione della qualità (materiali, legante, realizzazione) e per ognuno è possibile segnalare anche la presenza di cordoli o catene se sono sufficientemente diffusi; è anche da rilevare l'eventuale presenza di pilastri isolati, siano essi in c.a., muratura, acciaio o legno e/o la presenza di situazioni miste di muratura e strutture intelaiate. Gli edifici si considerano con strutture intelaiate/pareti di c.a., acciaio o legno, se l'intera struttura portante è in c.a., acciaio o legno. Situazioni miste (muratura-telai) o rinforzi vanno indicate, con modalità multiscelta, nelle colonne G ed H della parte "muratura" (per le miste compilare sia "muratura", sia "altre strutture").

G1: c.a. (o altre strutture intelaiate) su muratura

G2: muratura su c.a. (o altre strutture intelaiate)

G3: muratura mista a c.a. (o altre strutture intelaiate) in parallelo sugli stessi piani

H1: muratura rinforzata con iniezioni o intonaci non armati

H2: muratura armata o con intonaci armati

H3: muratura con altri o non identificati rinforzi

La compilazione della *Regolarità* compete solo alle *Altre strutture*.

Per le strutture intelaiate le tamponature sono irregolari quando presentano dissimmetrie in pianta e/o in elevazione o sono in pratica completamente assenti in un piano in almeno una direzione.

### Sezione 4 - Danni ad ELEMENTI STRUTTURALI ...

I danni da riportare nella sezione 4 sono quelli "apparenti", cioè quelli riscontrabili a vista. Nella tabella ogni riga è riferita ad un tipo di componente l'organismo strutturale, mentre le colonne sono differenziate in modo da consentire di rilevare i livelli di danno presenti sulla componente e le relative estensioni in percentuale rispetto alla sua totalità nell'edificio. La definizione del livello di danno riscontrato è di particolare rilevanza, essa è basata sulla scala macrosismica europea EMS98, integrata con le definizioni puntuali utilizzate nelle schede di rilievo GNDT. In particolare si farà riferimento alla sommaria descrizione riportata di seguito, maggiori dettagli sono riportati nel manuale:

**D1 DANNO LEGGERO:** è un danno che non cambia in modo significativo la resistenza della struttura e non pregiudica la sicurezza degli occupanti a causa di cadute di elementi non strutturali.

**D2-D3 DANNO MEDIO - GRAVE:** è un danno che potrebbe anche cambiare in modo significativo la resistenza della struttura senza che venga avvicinato palesemente il limite del crollo parziale di elementi strutturali principali.

**D4-D5 DANNO GRAVISSIMO:** è un danno che modifica in modo evidente la resistenza della struttura portandola vicino al limite del crollo parziale o totale di elementi strutturali principali. Stato descritto da danni superiori ai precedenti, incluso il collasso.

**PROVVEDIMENTI DI PRONTO INTERVENTO ESEGUITI:** sono quelli che con tempi e mezzi limitati conseguono una eliminazione o riduzione accettabile del rischio; vanno indicati quelli già messi in atto.

### Sezione 5 - Danni ad ELEMENTI NON STRUTTURALI...

Per gli elementi non strutturali va indicata la presenza del danno e gli eventuali provvedimenti già in atto, con modalità multiscelta.

### Sezione 6 - Pericolo ESTERNO ed interventi di p.i. eseguiti

Indicare i pericoli indotti da costruzioni adiacenti e/o dal contesto e gli eventuali provvedimenti presi, con modalità multiscelta.

### Sezione 7 - Terreno e fondazioni

Va individuata la morfologia del sito ed eventuali evidenze di dissesti connessi al terreno di fondazione.

### Sezione 8 - Giudizio di AGIBILITÀ

La squadra stabilisce le condizioni di rischio dell'edificio (tabella 8-A *valutazione del rischio*) sulla base delle informazioni raccolte, dell'ispezione visiva e delle proprie valutazioni, relativamente alle condizioni strutturali (Sezioni 3 e 4), alle condizioni degli elementi non strutturali (Sezione 5), al pericolo derivante da elementi esterni (Sezione 6) e alla situazione geotecnica (Sezione 7). Il giudizio va emesso tenendo conto che: *La valutazione di agibilità in emergenza post-sismica è una valutazione temporanea e speditiva - vale a dire formulata sulla base di un giudizio esperto e condotta in tempi limitati, in base alla semplice analisi visiva ed alla raccolta di informazioni facilmente accessibili - volta a stabilire se, in presenza di una crisi sismica in atto, gli edifici colpiti dal terremoto possano essere utilizzati restando ragionevolmente protetta la vita umana.* L'esito **A** va scelto, quindi, se si soddisfa pienamente la precedente definizione. L'esito **B** va indicato quando la riduzione del rischio (totale o parziale) si può conseguire con il *pronto intervento (opere di consistenza limitata, di rapida e facile esecuzione che rendono agibile l'edificio)*; in tal caso occorre compilare anche la Sez. 8-D. L'esito **C** va indicato se l'edificio presenta una situazione di rischio che condiziona l'agibilità di una sola parte, ben definita, del manufatto. L'esito **D** va indicato solo in casi particolarmente problematici tali da rendere incerto il giudizio di agibilità da parte della squadra; in tal caso va specificata la motivazione dell'approfondimento. L'esito **E** va indicato se l'edificio non può essere utilizzato in alcuna delle sue parti, neanche a seguito di provvedimenti di pronto intervento. L'esito **F** va usato in multiscelta, nei casi in cui sussistono anche condizioni di rischio esterno.

**UNITÀ IMMOBILIARI INAGIBILI, FAMIGLIE E PERSONE EVACUATE:** sono da indicare gli effetti del giudizio di inagibilità, qualora confermato dal Sindaco; vanno pertanto indicate anche le famiglie e persone da evacuare, oltre a quelle che abbiano già lasciato l'edificio.

**PROVVEDIMENTI DI PRONTO INTERVENTO:** indicare i provvedimenti necessari per rendere agibile l'edificio e/o per eliminare rischi indotti.

### Sezione 9 - Altre osservazioni

**ACCURATEZZA DELLA VISITA:** indicare con quale livello di accuratezza e completezza è stato possibile effettuare il sopralluogo.

**SUL DANNO, SUI PROVVEDIMENTI DI PRONTO INTERVENTO, L'AGIBILITÀ O ALTRO:** riportare le annotazioni che si ritengono importanti per meglio precisare i vari aspetti del rilevamento. L'eventuale fotografia d'insieme dell'edificio deve essere spillata nel riquadro tratteggiato in chiaro e nel solo angolo in alto a destra. In questa sezione riportare le parti di edificio inagibili (esiti B, C), i provvedimenti di pronto intervento che possono rimuovere l'inagibilità (esito B) o necessari per la sicurezza esterna (esiti C, D, E, F), le motivazioni del tipo di approfondimento richiesto (esito D), le cause di rischio esterno (esito F).

**LA SCHEDA VA FIRMATA DA TUTTI I COMPONENTI DELLA SQUADRA DI ISPEZIONE.**

- **MODEL A-DC Churches – first-level**

The “MODEL A-DC Churches” (hereafter A-DC form) is the first form studied and, for this reason, it has undergone several adjustments. It has been studied since the 1976 earthquake specifically for religious buildings, and since the first formulation, it identified the façade, the nave, the aisles, the apse, the chapels and the tower bell as macro-elements, typical architectural features found in churches. In its final design, it lists 28 collapse mechanisms compared to 18 previously used. Indeed, in the version approved in 2006 (Papa, Di Pasquale, 2013), 4 additional recurrent collapse mechanisms were introduced for previously identified macro-elements, plus 6 mechanisms related to 3 new macro-elements: the prothyrum, the transept and the roof lantern.

The form is organised in two sections. The first, structured in 13 subsections (A1-A13), is aimed at characterising property and its location, even in connection with the urban context, and identifying pieces of art contained within it. The second one, structured in 13 subsections (A14-A27), assesses the state of conservation and the damage index; expresses a judgement of usability and identifies repair costs.

Regarding the second section it is necessary to make some clarifications.

First of all, although they are non-structural elements, the projecting elements such as pinnacles, spires or statues are included within the collapse mechanisms list (in particular Mechanism 26). This choice for the A-DC form was made according to the assumption that the distinction between structural and non-structural elements for churches should be considered “meaningless” (Lagomarsino, Podestà, 2004a) . On the contrary this subdivision is still present on AeDES form. Indeed, the presence of such elements within churches is intrinsic to the type itself. Since they represent an element of strong vulnerability (elements not braced or simply supported), their damage has been included within the structural elements.

Another clarification should be made with regard to the calculation of the damage index. This clarification is necessary in reference to a different system of index calculating for the B-DP form. In particular, the damage index of A-DC form is calculated by taking into account all possible collapse mechanisms that may be activated among the 28 present (determining the parameter “N”) and the level of damage associated with each of them (determining the parameter “d”). The damage index,  $I_d = d/5N$ , is then obtained by the ratio of the two factors collected. It is worth mentioning that “N” is represented by the sum of all possible mechanisms, regardless of how many times a macro-element is used. The presence, as example, of three or five aisles is therefore irrelevant for the index calculation. Finally, in order to calculate “N”, each collapse mechanism associated with a macro-element must be considered as vulnerable purely because the macro-element is in the church. The presence of the transept, for example, implies the marking of mechanisms 10, 11, 12 and 20. Indeed, all of these mechanisms are related to that macro-element.

For the identification of “d” we proceed to the sum of all the damage levels reported for each possible collapse mechanism previously marked.

Finally, the damage levels provided in the initial formulations were graduated on a scale from 1 to 3. However, since the first approved version in 2001, they have been replaced with

the subdivision into 5 levels according to the European standard EMS-98 (Grünthal, 1998).

1	RIBALTAMENTO DELLA FACCIATA	<input type="checkbox"/>	N
danno	DISTACCO DELLA FACCIATA DALLE PARETI	<input type="checkbox"/> <input type="checkbox"/> <input type="checkbox"/> <input type="checkbox"/> <input type="checkbox"/>	d

Fig.22. Identification of data corresponding to "N" and "d" for a type damage mode.

An empty model of the instrument below:



Presidenza del Consiglio dei Ministri  
DIPARTIMENTO DELLA PROTEZIONE CIVILE



Ministero  
per i Beni e le Attività Culturali

GRUPPO DI LAVORO PER LA SALVAGUARDIA E LA PREVENZIONE DEI BENI CULTURALI DAI RISCHI NATURALI



SISMA

EMERGENZA POST-SISMA

**SCHEDA PER IL RILIEVO DEL DANNO AI BENI CULTURALI – CHIESE**

**MODELLO A – DC**

Prima sezione

**A<sub>1</sub>**

Data	__ __ __ __ __	N° progressivo	__ __	N° Scheda	__ __ __ __ __
					<small>(a cura dell'ufficio)</small>

**A<sub>2</sub> – RIFERIMENTO VERTICALE**

Bene complesso	<input type="radio"/>	Bene individuo	<input type="radio"/>
Denominazione bene complesso:	__ __ __ __ __		
Numero schede beni componenti	__ __	Codice livello superiore	__ __ __ __ __
Tipologia	<input type="checkbox"/> chiesa <input type="checkbox"/> canonica <input type="checkbox"/> palazzo <input type="checkbox"/> castello <input type="checkbox"/> torre <input type="checkbox"/> bene archeologico <input type="checkbox"/> altro		
Pianta	<input type="radio"/> regolare <input type="radio"/> con cortili <input type="radio"/> ad ali aperte <input type="radio"/> lineare <input type="radio"/> altro __ __ __ __ __		

**A<sub>3</sub> – LOCALIZZAZIONE GEOGRAFICO AMMINISTRATIVA**

Regione	__ __ __ __ __	Codice Istat comune	__ __ __ __ __	<b>Indirizzo</b> 1 <input type="radio"/> via 2 <input type="radio"/> corso 3 <input type="radio"/> vicolo 4 <input type="radio"/> piazza 5 <input type="radio"/> località		
Provincia	__ __ __ __ __	__ __ __ __ __				
Comune	__ __ __ __ __					
Località	__ __ __ __ __					
Sezione censuaria	__ __ __ __	N° complesso o aggregato	__ __ __ __	N° edificio	__ __ __	
Foglio	__ __ __	Data	__ __ __ __ __	Particelle	__ __ __ __	
					num.civico	__ __ __

**A<sub>4</sub> – COORDINATE UTM**

Quadrante	__ __ __	Longitudine Est (x)	__ __ ° __ __'	Latitudine Nord (y)	__ __ ° __ __'	<input type="radio"/> Lettura GPS
-----------	----------	---------------------	----------------	---------------------	----------------	-----------------------------------

**A<sub>5</sub> – OGGETTO**

Denominazione bene:	__ __ __ __ __				
Denominazione storica:	__ __ __ __ __				
Datazione: anno	__ __ __	secolo	__	epoca	__ __ __ __ __
				Ultima trasformazione	__ __ __
Proprietà:	__ __ __ __ __				__ __ __ __ __
Utilizzatore:	__ __ __ __ __				__ __ __ __ __

**A<sub>6</sub> – DESTINAZIONE D'USO ATTUALE**

Uso	Utilizzazione temporale			Affollamento
	Continuo	Saltuario	Non utilizzato	
Cattedrale / Duomo <input type="checkbox"/>	<input type="radio"/>	<input type="radio"/>	<input type="radio"/>	<input type="checkbox"/>
Chiesa parrocchiale <input type="checkbox"/>	<input type="radio"/>	<input type="radio"/>	<input type="radio"/>	<input type="checkbox"/>
Oratorio <input type="checkbox"/>	<input type="radio"/>	<input type="radio"/>	<input type="radio"/>	<input type="checkbox"/>
Santuario <input type="checkbox"/>	<input type="radio"/>	<input type="radio"/>	<input type="radio"/>	<input type="checkbox"/>
Museo <input type="checkbox"/>	<input type="radio"/>	<input type="radio"/>	<input type="radio"/>	<input type="checkbox"/>
Auditorium <input type="checkbox"/>	<input type="radio"/>	<input type="radio"/>	<input type="radio"/>	<input type="checkbox"/>
Servizi <input type="checkbox"/>	<input type="radio"/>	<input type="radio"/>	<input type="radio"/>	<input type="checkbox"/>
Altro <input type="checkbox"/> _____	<input type="radio"/>	<input type="radio"/>	<input type="radio"/>	<input type="checkbox"/>

**A<sub>7</sub> – CARATTERISTICHE DEL SITO**

In piano  Su rilievo / su cresta / su vetta  Su riporto  In pendio / su versante  Avvallamento

**A<sub>8</sub> – CONTESTO URBANO E POSIZIONE**

Centro urbano  Periferia urbana  Area industriale - commerciale  Area agricola  Centro storico

Isolata  Connessa con altri edifici  su \_\_\_\_\_ lati Altro  .....

**A<sub>9</sub> – INFRASTRUTTURE**

Accesso pedonale <input type="radio"/>	<input type="radio"/>	Rete viaria idonea in relazione al rischio	<input type="checkbox"/>
Accesso carrabile <input type="radio"/>	<input type="radio"/>	Parcheggio nelle vicinanze	<input type="checkbox"/>
Accesso con altezza inferiore a 4 metri <input type="radio"/>	<input type="radio"/>	Spazi aperti a disposizione	<input type="checkbox"/>
Accesso con mezzi pesanti <input type="radio"/>	<input type="radio"/>	Altro <input type="checkbox"/> _____	

**A<sub>10</sub> – PRESENZA DI RISCHIO**

		RILEVAZIONE DIRETTA	INFORMAZIONI ACQUISITE
Insedimento minacciato da frana	<input type="checkbox"/>	<input type="radio"/>	<input type="radio"/>
Insedimento in zona alluvionabile	<input type="checkbox"/>	<input type="radio"/>	<input type="radio"/>
Insedimento soggetto a minacce di tipo industriale	<input type="checkbox"/>	<input type="radio"/>	<input type="radio"/>
Insedimento soggetto ad altre minacce naturali	<input type="checkbox"/>	<input type="radio"/>	<input type="radio"/>

**A<sub>11</sub> – TIPOLOGIA DEI BENI ARTISTICI PRESENTI**

TIPOLOGIA		Num.	superficie	TIPOLOGIA		Num.	superficie
Affreschi	<input type="checkbox"/>	__	___	Dipinti mobili su vario supporto	<input type="checkbox"/>	__	___
Mosaici	<input type="checkbox"/>	__	___	Arredi (soffitti, amboni, pulpito, stali corali)	<input type="checkbox"/>	__	___
Stucchi	<input type="checkbox"/>	__	___	Decorazioni plastiche mobili	<input type="checkbox"/>	__	___
Arazzi	<input type="checkbox"/>	__	___	Manufatti in carta e pergamena	<input type="checkbox"/>	__	___
Altari / statue	<input type="checkbox"/>	__	___	Reperti archeologici	<input type="checkbox"/>	__	___
Libri / Stampe	<input type="checkbox"/>	__	___	Altri .....	<input type="checkbox"/>	__	___

**A<sub>12</sub> – DOCUMENTAZIONE FOTOGRAFICA** - Realizzata da .....  SI  NO

**A<sub>13</sub> – COMPILATORE SCHEDA**

Cognome \_\_\_\_\_ Nome \_\_\_\_\_

Ente/ufficio di appartenenza \_\_\_\_\_

 \_\_\_\_\_ E-Mail: .....

**A<sub>14</sub> - RIFERIMENTO SCHEDA DELLA VULNERABILITA' DELLE CHIESE**

N° Scheda	Data	Ente
-----------	------	------

**A<sub>15</sub> - STATO DI MANUTENZIONE GENERALE**

Buono <input type="radio"/>	Discreto <input type="radio"/>	Scadente <input type="radio"/>	Pessimo <input type="radio"/>	In corso lavori <input type="checkbox"/>		
Eventuali precedenti lesioni esistenti		NO <input type="radio"/>	SI <input type="radio"/>	Limitate <input type="radio"/>	Estese <input type="radio"/>	Gravi <input type="radio"/>

**A<sub>16</sub> - DANNO SISMICO (Abaco dei meccanismi di collasso delle chiese)**

**LIVELLO DI DANNO**

0 - □□□□ assenza di danno    1 - ■□□□ danno lieve    2 - ■■□□ danno moderato  
 3 - ■■■□ danno grave    4 - ■■■■□ danno molto grave    5 - ■■■■■ crollo

**IDENTIFICAZIONE DEL DANNO**

danno sismico  
 danno progressivo  
 aggravamento

1	<b>RIBALTAMENTO DELLA FACCIATA</b>	<input type="checkbox"/>
danno	DISTACCO DELLA FACCIATA DALLE PARETI O EVIDENTI FUORI PIOMBO	□□□□
2	<b>MECCANISMI NELLA SOMMITÀ DELLA FACCIATA</b>	<input type="checkbox"/>
danno	RIBALTAMENTO DEL TIMPANO, CON LESIONE ORIZZONTALE O A V – DISGREGAZIONE DELLA MURATURA O SCORRIMENTO DEL CORDOLO – ROTAZIONE DELLE CAPRIATE	□□□□
3	<b>MECCANISMI NEL PIANO DELLA FACCIATA</b>	<input type="checkbox"/>
danno	LESIONI INCLINATE (TAGLIO) – LESIONI VERTICALI O ARCUATE (ROTAZIONE) – ALTRE FESSURAZIONI O SPANCIAMENTI	□□□□
4	<b>PROTIRO – NARTECE</b>	<input type="checkbox"/>
danno	LESIONI NEGLI ARCHI O NELLA TRABEAZIONE PER ROTAZIONE DELLE COLONNE – DISTACCO DALLA FACCIATA – MARTELLAMENTO	□□□□
5	<b>RISPOSTA TRASVERSALE DELL’AULA</b>	<input type="checkbox"/>
danno	LESIONI NEGLI ARCONI (CON EVENTUALE PROSECUZIONE NELLA VOLTA) – ROTAZIONI DELLE PARETI LATERALI – LESIONI A TAGLIO NELLE VOLTE – FUORI PIOMBO E SCHIACCIAMENTO NELLE COLONNE	□□□□
6	<b>MECCANISMI DI TAGLIO NELLE PARETI LATERALI (RISPOSTA LONGITUDINALE)</b>	<input type="checkbox"/>
danno	LESIONI INCLINATE (SINGOLE O INCROCIATE) – LESIONI IN CORRISPONDENZA DI DISCONTINUITÀ NELLA MURATURA	□□□□
7	<b>RISPOSTA LONGITUDINALE DEL COLONNATO NELLE CHIESE A PIÙ NAVATE</b>	<input type="checkbox"/>
danno	LESIONI NEGLI ARCHI O NEGLI ARCHITRAVI LONGITUDINALI – SCHIACCIAMENTO E/O LESIONI ALLA BASE DEI PILASTRI – LESIONI A TAGLIO NELLE VOLTE DELLE NAVATE LATERALI	□□□□
8	<b>VOLTE DELLA NAVATA CENTRALE</b>	<input type="checkbox"/>
danno	LESIONI NELLE VOLTE DELL’AULA CENTRALE – SCONNESSIONI DELLE VOLTE DAGLI ARCONI	□□□□
9	<b>VOLTE DELLE NAVATE LATERALI</b>	<input type="checkbox"/>
danno	LESIONI NELLE VOLTE O SCONNESSIONI DAGLI ARCONI O DALLE PARETI LATERALI	□□□□
10	<b>RIBALTAMENTO DELLE PARETI DI ESTREMITÀ DEL TRANSETTO</b>	<input type="checkbox"/>
danno	DISTACCO DELLA PARETE FRONTALE DALLE PARETI LATERALI – RIBALTAMENTO O DISGREGAZIONI DEL TIMPANO IN SOMMITÀ	□□□□
11	<b>MECCANISMI DI TAGLIO NELLE PARETI LATERALI DEL TRANSETTO</b>	<input type="checkbox"/>
danno	LESIONI INCLINATE (SINGOLE O INCROCIATE) – LESIONI ATTRAVERSO DISCONTINUITÀ	□□□□
12	<b>VOLTE DEL TRANSETTO</b>	<input type="checkbox"/>
danno	LESIONI NELLE VOLTE O SCONNESSIONI DAGLI ARCONI E DALLE PARETI LATERALI	□□□□
13	<b>ARCHI TRIONFALI</b>	<input type="checkbox"/>
danno	LESIONI NELL’ARCO – SCORRIMENTO DI CONCI – SCHIACCIAMENTO O LESIONI ORIZZONTALI ALLA BASE DEI PIEDRITTI	□□□□

14	<b>CUPOLA – TAMBURO/TIBURIO</b>	<input type="checkbox"/>
danno	LESIONI NELLA CUPOLA (AD ARCO) CON EVENTUALE PROSECUZIONE NEL TAMBURO	<input type="checkbox"/> <input type="checkbox"/> <input type="checkbox"/> <input type="checkbox"/> <input type="checkbox"/>
15	<b>LANTERNA</b>	<input type="checkbox"/>
danno	LESIONI NEL CUPOLINO DELLA LANTERNA – ROTAZIONI O SCORRIMENTI DEI PIEDRITTI	<input type="checkbox"/> <input type="checkbox"/> <input type="checkbox"/> <input type="checkbox"/> <input type="checkbox"/>
16	<b>RIBALTAMENTO DELL'ABSIDE</b>	<input type="checkbox"/>
danno	LESIONI VERTICALI O ARCUATE NELLE PARETI DELL'ABSIDE – LESIONI VERTICALI NEGLI ABSIDI POLIGONALI – LESIONE AD U NEGLI ABSIDI SEMICIRCOLARI	<input type="checkbox"/> <input type="checkbox"/> <input type="checkbox"/> <input type="checkbox"/> <input type="checkbox"/>
17	<b>MECCANISMI DI TAGLIO NEL PRESBITERIO O NELL'ABSIDE</b>	<input type="checkbox"/>
danno	LESIONI INCLINATE (SINGOLE O INCROCIATE) – LESIONI IN CORRISPONDENZA DI DISCONTINUITÀ MURARIE	<input type="checkbox"/> <input type="checkbox"/> <input type="checkbox"/> <input type="checkbox"/> <input type="checkbox"/>
18	<b>VOLTE DEL PRESBITERIO O DELL'ABSIDE</b>	<input type="checkbox"/>
danno	LESIONI NELLE VOLTE O SCONNESSIONI DAGLI ARCONI O DALLE PARETI LATERALI	<input type="checkbox"/> <input type="checkbox"/> <input type="checkbox"/> <input type="checkbox"/> <input type="checkbox"/>
19	<b>MECCANISMI NEGLI ELEMENTI DI COPERTURA – PARETI LATERALI DELL'AULA</b>	<input type="checkbox"/>
danno	LESIONI VICINE ALLE TESTE DELLE TRAVI LIGNEE, SCORRIMENTO DELLE STESSE – SCONNESSIONI TRA CORDOLI E MURATURA – MOVIMENTI SIGNIFICATIVI DEL MANTO DI COPERTURA	<input type="checkbox"/> <input type="checkbox"/> <input type="checkbox"/> <input type="checkbox"/> <input type="checkbox"/>
20	<b>MECCANISMI NEGLI ELEMENTI DI COPERTURA – TRANSETTO</b>	<input type="checkbox"/>
danno	LESIONI VICINE ALLE TESTE DELLE TRAVI LIGNEE, SCORRIMENTO DELLE STESSE – SCONNESSIONI TRA CORDOLI E MURATURA – MOVIMENTI SIGNIFICATIVI DEL MANTO DI COPERTURA	<input type="checkbox"/> <input type="checkbox"/> <input type="checkbox"/> <input type="checkbox"/> <input type="checkbox"/>
21	<b>MECCANISMI NEGLI ELEMENTI DI COPERTURA – ABSIDE E PRESBITERIO</b>	<input type="checkbox"/>
danno	LESIONI VICINE ALLE TESTE DELLE TRAVI LIGNEE, SCORRIMENTO DELLE STESSE – SCONNESSIONI TRA CORDOLI E MURATURA – MOVIMENTI SIGNIFICATIVI DEL MANTO DI COPERTURA	<input type="checkbox"/> <input type="checkbox"/> <input type="checkbox"/> <input type="checkbox"/> <input type="checkbox"/>
22	<b>RIBALTAMENTO DELLE CAPPELLE</b>	<input type="checkbox"/>
danno	DISTACCO DELLA PARETE FRONTALE DALLE PARETI LATERALI	<input type="checkbox"/> <input type="checkbox"/> <input type="checkbox"/> <input type="checkbox"/> <input type="checkbox"/>
23	<b>MECCANISMI DI TAGLIO NELLE PARETI DELLE CAPPELLE</b>	<input type="checkbox"/>
danno	LESIONI INCLINATE (SINGOLE O INCROCIATE) – LESIONI IN CORRISPONDENZA DI DISCONTINUITÀ MURARIE	<input type="checkbox"/> <input type="checkbox"/> <input type="checkbox"/> <input type="checkbox"/> <input type="checkbox"/>
24	<b>VOLTE DELLE CAPPELLE</b>	<input type="checkbox"/>
danno	LESIONI NELLE VOLTE O SCONNESSIONI DALLE PARETI LATERALI	<input type="checkbox"/> <input type="checkbox"/> <input type="checkbox"/> <input type="checkbox"/> <input type="checkbox"/>
25	<b>INTERAZIONI IN PROSSIMITÀ DI IRREGOLARITÀ PLANO-ALTIMETRICHE (CORPI ADIACENTI, ARCHI RAMPANTI)</b>	<input type="checkbox"/>
danno	MOVIMENTO IN CORRISPONDENZA DI DISCONTINUITÀ COSTRUTTIVE - LESIONI NELLA MURATURA PER MARTELLAMENTO	<input type="checkbox"/> <input type="checkbox"/> <input type="checkbox"/> <input type="checkbox"/> <input type="checkbox"/>
26	<b>AGGETTI (VELA, GUGLIE, PINNACOLI, STATUE)</b>	<input type="checkbox"/>
danno	EVIDENZA DI ROTAZIONI PERMANENTI O SCORRIMENTO – LESIONI	<input type="checkbox"/> <input type="checkbox"/> <input type="checkbox"/> <input type="checkbox"/> <input type="checkbox"/>
27	<b>TORRE CAMPANARIA</b>	<input type="checkbox"/>
danno	LESIONI VICINO ALLO STACCO DAL CORPO DELLA CHIESA – LESIONI A TAGLIO O SCORRIMENTO – LESIONI VERTICALI O ARCUATE (ESPULSIONE DI UNO O PIÙ ANGOLI)	<input type="checkbox"/> <input type="checkbox"/> <input type="checkbox"/> <input type="checkbox"/> <input type="checkbox"/>
28	<b>CELLA CAMPANARIA</b>	<input type="checkbox"/>
danno	LESIONI NEGLI ARCHI – ROTAZIONI O SCORRIMENTI DEI PIEDRITTI	<input type="checkbox"/> <input type="checkbox"/> <input type="checkbox"/> <input type="checkbox"/> <input type="checkbox"/>

**A<sub>17</sub> - INDICE DI DANNO**

n =  (numero dei meccanismi possibili)    d =  (punteggio totale di danno)     $i_d = d / 5n =$

**A<sub>18</sub> - AGIBILITA'**

<b>Agibile</b> <input type="radio"/>	<b>Inagibile</b> <input type="radio"/>		
<b>Parzialmente Agibile</b> <input type="radio"/>	<b>Agibile con Provvedimenti</b> <input type="radio"/>	<b>Temporaneamente Inagibile</b> <input type="radio"/>	<b>Inagibile per cause Esterne</b> <input type="radio"/>
Indicare le parti agibili ..... ..... ..... ..... ..... ..... .....	Segnalare i provvedimenti anche indicandoli nella tabella sottostante ..... ..... ..... ..... ..... .....	<input type="checkbox"/> Verifica più accurata <input type="checkbox"/> Si consiglia visita di esperti <input type="checkbox"/> Altro ..... ..... ..... ..... .....	Indicare le cause esterne ..... ..... ..... ..... ..... .....

**A<sub>19</sub> - TIPO DI VISITA**

Completa <input type="radio"/>	Parziale <input type="radio"/>	Solo dall'esterno <input type="radio"/>	Motivi ostativi .....
--------------------------------	--------------------------------	---	-----------------------

**A<sub>20</sub> - PROVVEDIMENTI DI P.I. SUGGERITI** (\* interventi limitati \*\* interventi estesi)

	PROVVEDIMENTI	*	**		PROVVEDIMENTI	*	**
1	Revisione manto di copertura	<input type="checkbox"/>	<input type="checkbox"/>	8	Ripristino smaltimento delle acque meteoriche	<input type="checkbox"/>	<input type="checkbox"/>
2	Copertura provvisoria	<input type="checkbox"/>	<input type="checkbox"/>	9	Monitoraggio	<input type="checkbox"/>	<input type="checkbox"/>
3	Puntellamenti	<input type="checkbox"/>	<input type="checkbox"/>	10	Protezioni o consolidamenti su opere d'arte fisse	<input type="checkbox"/>	<input type="checkbox"/>
4	Rimozione delle macerie	<input type="checkbox"/>	<input type="checkbox"/>	11	Catalogazione e smontaggio delle parti pericolanti	<input type="checkbox"/>	<input type="checkbox"/>
5	Transennamenti / recinzioni / protezioni	<input type="checkbox"/>	<input type="checkbox"/>	12	Sgombero opere d'arte mobili	<input type="checkbox"/>	<input type="checkbox"/>
6	Consolidamenti localizzati	<input type="checkbox"/>	<input type="checkbox"/>	13	Raccolta sistematica dei frammenti	<input type="checkbox"/>	<input type="checkbox"/>
7	Messa in opera di cerchiatura e/o tiranti	<input type="checkbox"/>	<input type="checkbox"/>	14	Ricovero e protezione dei frammenti	<input type="checkbox"/>	<input type="checkbox"/>

**A<sub>21</sub> - DANNI ALL'APPARATO DECORATIVO E ALLE OPERE D'ARTE** (scheda dettagliata a parte)

<b>A<sub>21.1</sub></b> - Descrizione apparato decorativo o opera d'arte ..... ..... .....
<b>A<sub>21.2</sub></b> - Descrizione danno ..... ..... .....
<b>A<sub>21.3</sub></b> - Provvedimenti provvisionali sugli apparati decorativi e sgombero opere d'arte mobili  <div style="text-align: right;">SI CONSIGLIA INTERVENTO STORICO DELL'ARTE <input type="checkbox"/></div> ..... ..... .....
<b>STIMA DEL COSTO PER LA SALVAGUARDIA DELLE OPERE D'ARTE</b> <div style="text-align: right;">                     €                      <u>    </u><u>    </u><u>    </u> <u>    </u><u>    </u><u>    </u> ,00                 </div>



**A<sub>22</sub> - DESCRIZIONE E STIMA SOMMARIA DELLE OPERE NECESSARIE****A<sub>22.1</sub> - Descrizione opere di ripristino strutturale (nuovi danni e danni pregressi aggravati)**

.....

.....

.....

**STIMA DEL COSTO PER IL RIPRISTINO STRUTTURALE**

€      \_ \_ \_ \_ \_ ,00

**A<sub>22.2</sub> - Descrizione opere di finitura, impiantistica e miglioramento sismico collegate**

.....

.....

.....

**STIMA DEL COSTO OPERE FINITURA IMPIANTISTICA E MIGLIORAMENTO SISMICO**

€      \_ \_ \_ \_ \_ ,00

**A<sub>22.3</sub> - Descrizione opere di pronto intervento (eventualmente indicare anche il costo del P.I. "a finire")**

.....

.....

.....

**STIMA DEL COSTO OPERE DI PRONTO INTERVENTO**

€      \_ \_ \_ \_ \_ ,00

**A<sub>23</sub> - NOTE**

Indicare, eventualmente, altri danni non rilevabili dalla scheda (es. solai di calpestio, pavimentazioni ecc.)

.....

.....

.....

.....

.....

.....

.....

.....

.....

**A<sub>24</sub> - DATI DIMENSIONALI ( stimati  rilevati  )**

Aula (compresi navate, cappelle, transetti)	Larghezza mt.      _ _ _	Lunghezza mt.      _ _ _	Superficie mq.      _ _ _ _	Altezza media mt.      _ _ _
Abside	Larghezza mt.      _ _ _	Lunghezza mt.      _ _ _	Superficie mq.      _ _ _ _	Altezza media mt.      _ _ _
Facciata principale	Larghezza mt.      _ _ _	Altezza mt.      _ _ _	Superficie mq.      _ _ _ _	
Campanile	Larghezza mt.      _ _ _	Lunghezza mt.      _ _ _		Altezza mt.      _ _ _
Coperture chiesa	Larghezza mt.      _ _ _	Lunghezza mt.      _ _ _	Superficie mq.      _ _ _ _	Altezza massima mt.      _ _ _

**A<sub>25</sub> - ELABORATI GRAFICI** (piante, sezioni, prospetti, illustrazione di dissesti particolari, allegare eventualmente fotocopie)

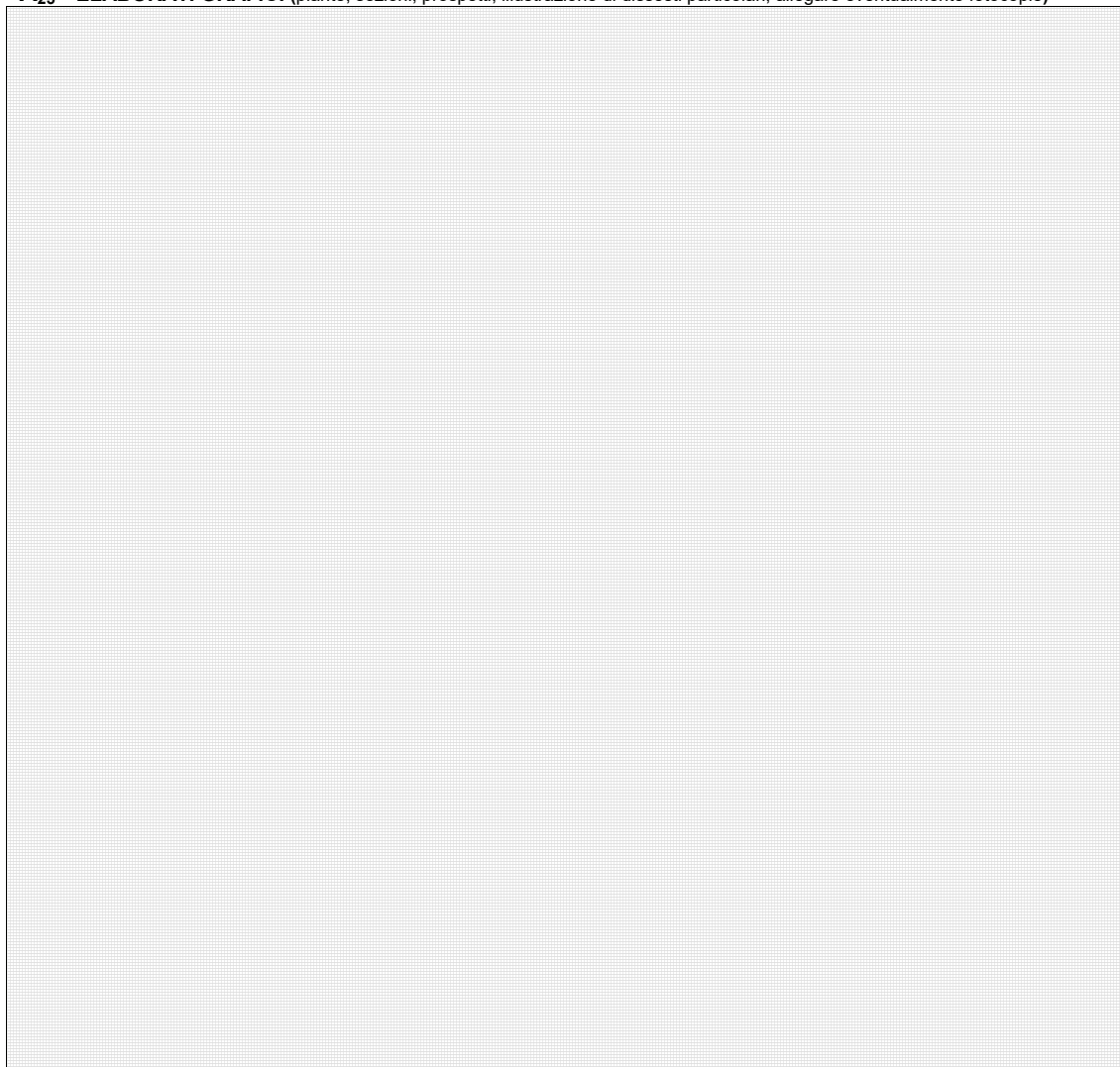

**A<sub>26</sub> - DOCUMENTAZIONE ALLEGATA**

SI  NO

.....
.....
.....

**A<sub>27</sub> - SQUADRA CHE HA ESEGUITO IL RILIEVO**

SISMA	C.O.M.	SQUADRA N.	
<i>Componenti della squadra</i>			
Cognome e nome	Qualifica	Ente appartenenza	Firma

Modello A-DC PCM-DPC MiBAC 2006

**ABACO DEI MECCANISMI DI COLLASSO DELLE CHIESE**

**1. RIBALTAMENTO DELLA FACCIATA**

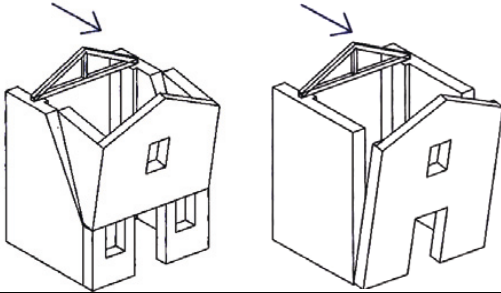

**2. MECCANISMI NELLA SOMMITÀ DELLA FACCIATA**

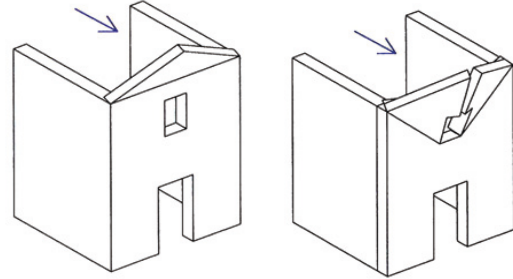

**3. MECCANISMI NEL PIANO DELLA FACCIATA**

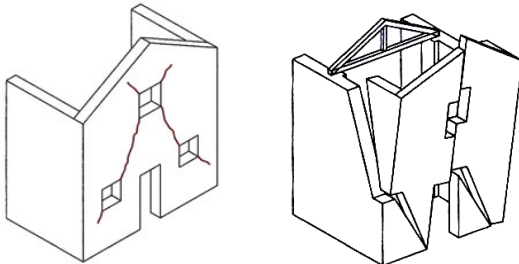

**4 - PROTIRO E NARTECE**

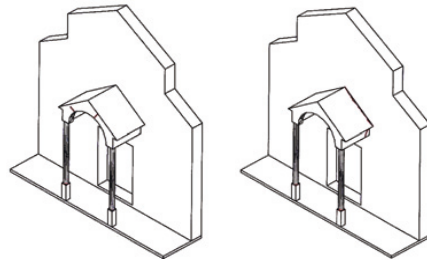

**5 - RISPOSTA TRASVERSALE DELL'AULA**

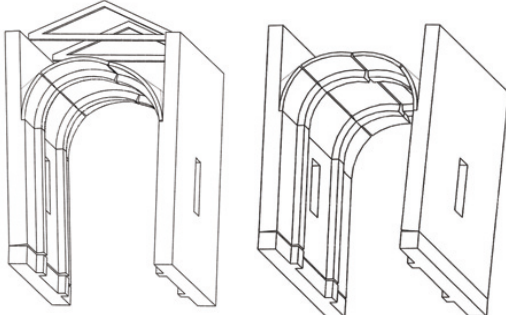

**6 - MECCANISMI DI TAGLIO PARETI LATERALI**

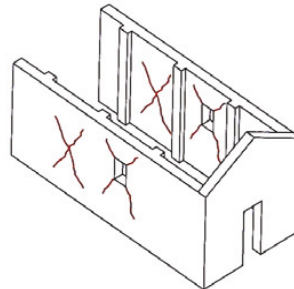

**7 - RISPOSTA LONGITUDINALE DEL COLONNATO**

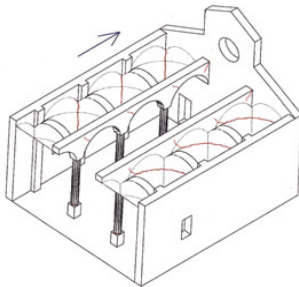

**8 - VOLTE DELL'AULA O DELLA NAVATA CENTRALE**

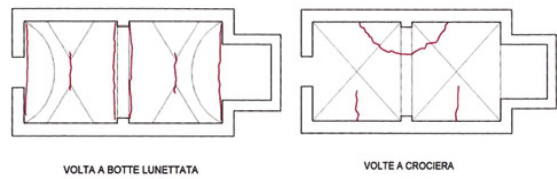

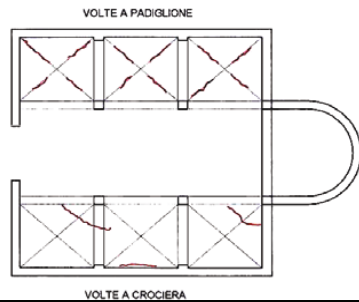

**9 - VOLTE DELLE NAVATE LATERALI**

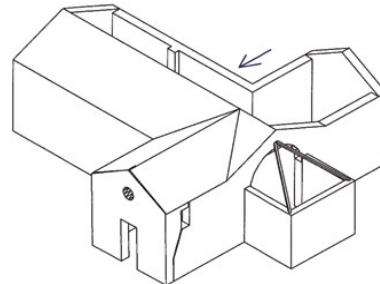

**10 - RIBALTAMENTO PARETI DEL TRANSETTO**

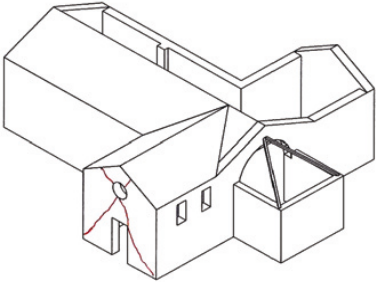
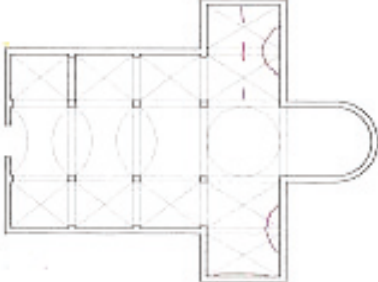
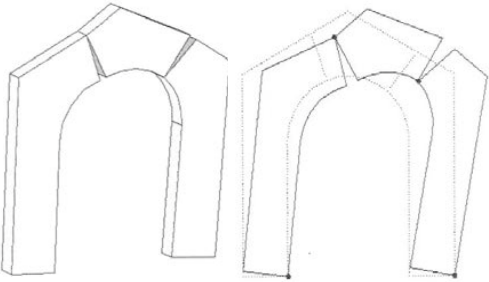
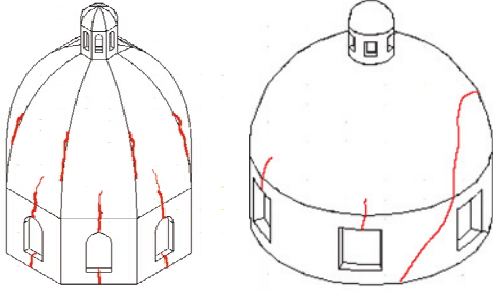
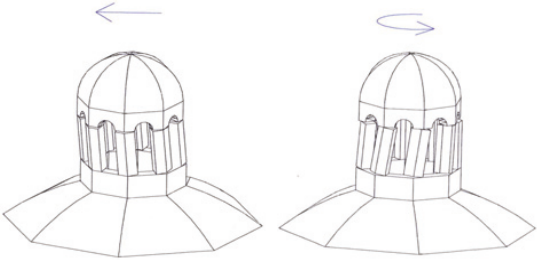
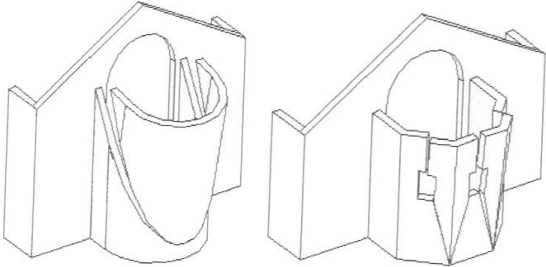
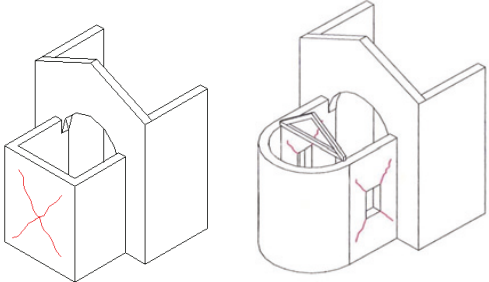
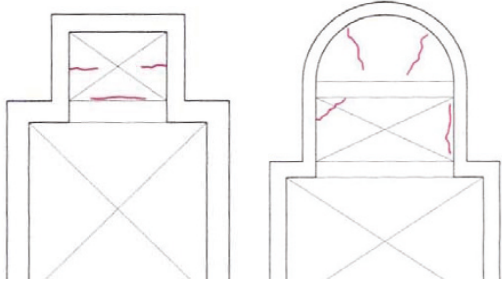
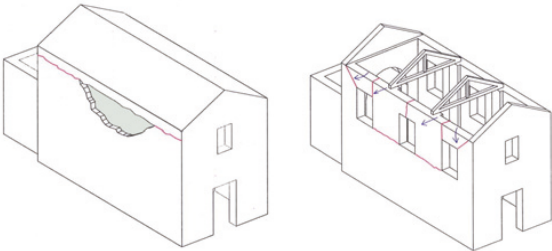
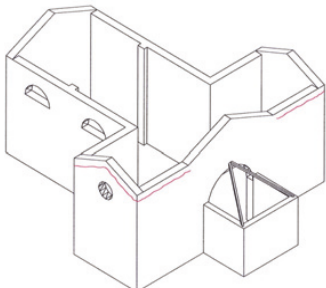

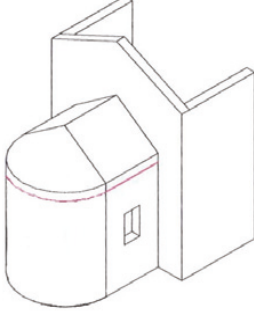
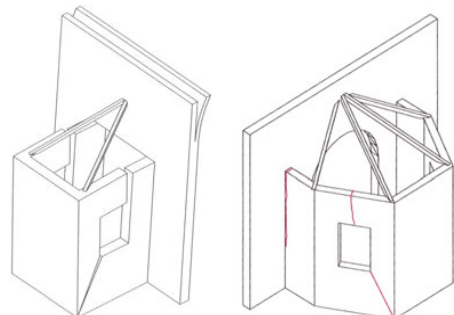
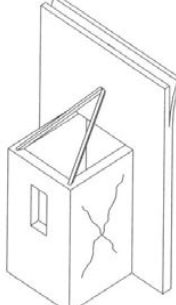
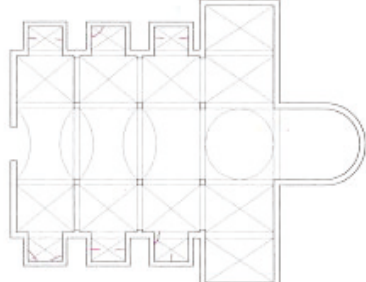
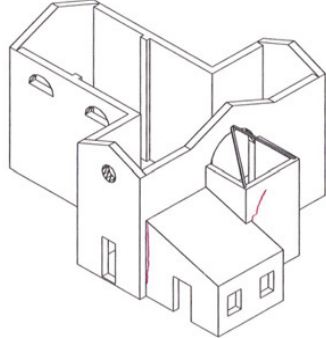
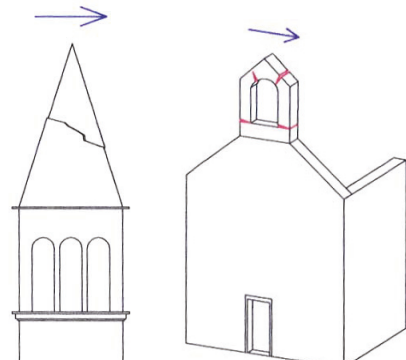
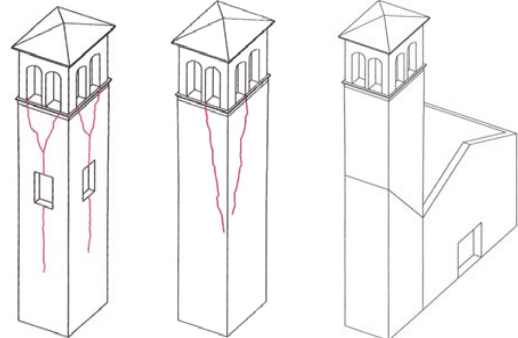
<p><b>11 - MECCANISMI DI TAGLIO DEL TRANSETTO</b></p> 	<p><b>12 - VOLTE DEL TRANSETTO</b></p> 
<p><b>13 - ARCHI TRIONFALI</b></p> 	<p><b>14 - CUPOLA E TAMBURO / TIBURIO</b></p> 
<p><b>15 - LANTERNA</b></p> 	<p><b>16 - RIBALTAMENTO DELL'ABSIDE</b></p> 
<p><b>17 - MECCANISMI DI TAGLIO NELL'ABSIDE</b></p> 	<p><b>18 - VOLTE DEL PRESBITERIO O DELL'ABSIDE</b></p> 
<p><b>19 - ELEMENTI DI COPERTURA: AULA</b></p> 	<p><b>20 - ELEMENTI DI COPERTURA: TRANSETTO</b></p> 

<p><b>21 - ELEMENTI DI COPERTURA: ABSIDE</b></p> 	<p><b>22 - RIBALTAMENTO DELLE CAPPELLE</b></p> 
<p><b>23 - MECCANISMI DI TAGLIO NELLE CAPPELLE</b></p> 	<p><b>24 - VOLTE DELLE CAPPELLE</b></p> 
<p><b>25 - INTERAZIONI IN PROSSIMITA' DI IRREGOLARITÀ</b></p> 	<p><b>26 - AGGETTI (VELA, GUGLIE, PINNACOLI, STATUE)</b></p> 
<p><b>27 - TORRE CAMPANARIA</b></p> 	<p><b>28 - CELLA CAMPANARIA</b></p> 

Modello A-DC PCM-DPC MiBAC 2006

- **MODEL B-DP Stately Building - first-level**

From a conceptual point of view, the “MODEL B-DP Stately Building” (hereafter B-DP form”) is divided into the same two sections as the A-DC form. The first section, structured as the A-DC form in 13 subsections, is focused on the identification of the necessary data to characterize and contextualize the building. The second, with 19 subsections, requires the data related to the state of preservation, the damage index, the practicability, and other similar data.

From a design point of view, the form differs considerably from the A-DC form. While the first sections are designed almost alike, adjusting only those data of higher variability such as intended use, spatial and temporal utilization (subsection B6), the second section is set up differently, despite aiming to collect the same data about conservative state, damage index and repair costs. For instance, as for basic buildings, the plan complexity and variability of a Stately building compared to a church result in a nonsensical decomposition into macro-elements. Therefore, instead of macro-elements in the B-DP form, we can find the decomposition into structural elements such as external perimeter walls, internal walls, floors, stairs, porticoes, and more.

Before being called to identify the activated collapse mechanisms for a building, the surveyor is required to provide a long and detailed description of materials, dimensions, and damage state of each individual component (subsection 19). In addition, there is a survey of elements considered non-structural and their state of damage (subsection 20). This is a further difference between forms. While in the A-DC form the non-structural elements and their damage are included in the damage index calculation, in the B-DP form they are listed and surveyed, but not included in the calculation.

Once this survey is being meticulously carried out, it would be possible to identify collapse mechanisms, their activation level, and calculate the damage index, but even if the damage index formula is the same, the identification of parameters for calculation (“n” and “d”) is quite different from the A-DC form (subsections B23, B23.1, and B23.2). This is the form section that differs most from the A-DC form, but despite this difference from the A-DC form being specifically in the most relevant part of the damage survey, to date there is no approved manual available for its correct compilation. This was undoubtedly one of the main problems experienced in the 2012 earthquake (Di Francesco, 2014). Today, checking also with internet support, it is possible to identify only two papers that resemble any type of B-DP “manual”. The first is a document<sup>24</sup> uploaded in 2021 on the site of the Tuscany region, called “ B-DP form guide”, which refers only to a summary description of the sections’ content and does not provide any explanation about how to fill in the form.

The second is a power-point presentation containing a section-by-section explanation of the form compilation. Unfortunately, any temporal indication or reference of authorship with regard to this file is missing, but it seems to supply exhaustive indications about how to compile the data on the damage index. The document is well structured and assuming it to be valid, displaying in the heading the correct titles, it becomes apparent that even if the damage index formula is the same, the identification of parameters for calculation

.....  
24 [https://www.regione.toscana.it/documents/10180/11807752/manuale\\_scheda\\_palazzi.pdf](https://www.regione.toscana.it/documents/10180/11807752/manuale_scheda_palazzi.pdf)

“N” and “d”) is quite different from A-DC form. As far as parameter “N” is concerned, the relative section provides a table where 22 potentially activatable mechanisms are proposed, clustered according to the structural elements they generally involve. It’s a 5-column table where in the second column, the elements constituting the building must be indicated, sometimes indicating their amount (e.g., the number of perimeter walls) and sometimes indicating only their presence (e.g., the presence of porches). In the third column then you can define the structural behaviours. The “ N “ calculation, however, does not depend on both columns, but only on the first of them, namely the number of structural elements constituting the building, a number which must take into account all the elements, whether they are damaged or not. The calculation of the “ d “ parameter as in A-DC form is dependent on the sum of the damage levels found on the elements, however in this case this sum does not necessarily take into account all the damage detected. The criteria for this choice are determined by a parameter specifically introduced in this form: the “secondary” parameter of subsection B23.1. The application of this code to the damage indicates that it should not be counted in the calculation of parameter “d” .

Contrary to the parameter’s name, it does not refer to the structural meaning of secondary mechanism; a mechanism that is triggered only after the activation of a previous one, enabling further kinematics having already weakened the structure. The analysis of the so-called kinematic chains is peculiar to the damage surveys of the detailed designs and, although it uses the same data that can be collected through the damage forms, it refers to a deeper building knowledge also in terms of historical material development. This integration in B-DP form is related to the complexity of stately buildings which are generally multi-storey buildings. In some elements we can observe different mechanisms on some floors with their related damage levels. Since among the location data of the damaged elements in the calculation section of “d” there is also the identification of the floor for any structural element, for example the external perimeter walls, it is possible to identify several mechanisms at different floors with their respective damage levels. In a multi-storey building, an external wall may be damaged by overturning on floors 3 and 4, mechanism M1, and by shear damage to wall bay, mechanisms M5 of the related abacus (Fig 23).

**SCHEDA PALAZZI - Seconda Sezione (Campo B<sub>23</sub>)**

N° PROGRESSIVO	CODICE MECCANISMO	AREA	PIANI	ELEMENTI INTERESSATI
1	M5	A1	0-1	PE6
2	M1	A1	2-3	PE6
3	M1/A2		2	
4				
...				

✓ Parete 6 : M1 “Ribaltamento delle pareti” che interessa i piani 2 e 3

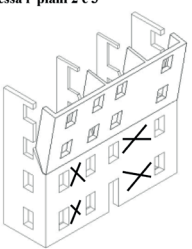

**SCHEDA PALAZZI - Seconda Sezione (Campo B<sub>23</sub>)**

Livello di attivazione articolato su 5 livelli (analagamente al danno degli elementi non strutturali) + indicazione sull' eventuale preesistenza

LIVELLO DI ATTIVAZIONE RISPETTO AL COLLASSO  
0 - □□□□□ assente    1 - ■□□□□ lieve    2 - ■■□□□ moderato  
3 - ■■■□□ grave    4 - ■■■■□ molto grave    5 - ■■■■■ esteso

IDENTIFICAZIONE DEL LIVELLO DI ATTIVAZIONE (P)  
A - stato attuale  
B - stato progressivo  
C - aggravamento

N° PROGRESSIVO	CODICE MECCANISMO	AREA	PIANI	ELEMENTI INTERESSATI	SECONDARIO	LIVELLO DI ATTIVAZIONE RISPETTO AL COLLASSO	P
1	M5	A1	1-2	PE6	X	X X □ □ □ □	□
2	M1	A1	3-4	PE6	X	X X X □ □ □	□
						□ □ □ □ □ □	□
						□ □ □ □ □ □	□
						□ □ □ □ □ □	□
						□ □ □ □ □ □	□
						□ □ □ □ □ □	□
						□ □ □ □ □ □	□

**Meccanismo di collasso primario :**  
quello che presenta il livello di attivazione più alto! → di conseguenza determinati quelli secondari

**Meccanismo di collasso primario :**  
nel caso delle pareti interne possono essere definiti collassi primari indipendenti nelle due direzioni per ciascuna area

Fig.23. Images taken from the B-DB form web instruction. Source [http://www.itiservizi.com/wp-content/uploads/file/MANUALE\\_PALAZZI.pdf](http://www.itiservizi.com/wp-content/uploads/file/MANUALE_PALAZZI.pdf)

In order not to overestimate the damage level in a component, the code “secondary” should therefore be attributed to all collapse mechanisms with the lowest damaging effect

in the same macro-element. This means that for each macro-element, only the collapse mechanism with the highest damage value should be considered.

Only after having identified all the elements of the building, the relative damages and identified the secondary ones, is it possible to calculate the damage index.

An empty model of the instrument below:





Presidenza del Consiglio dei Ministri  
DIPARTIMENTO DELLA PROTEZIONE CIVILE



Ministero  
per i Beni e le Attività Culturali

GRUPPO DI LAVORO PER LA SALVAGUARDIA E LA PREVENZIONE DEI BENI CULTURALI DAI RISCHI NATURALI



SISMA

EMERGENZA POST-SISMA

**SCHEDA PER IL RILIEVO DEL DANNO AI BENI CULTURALI - PALAZZI**

**MODELLO B - DP**

Prima sezione

**B<sub>1</sub>**

Data	__ __ __ __ __ __	N° progressivo	__ __ __	N° Scheda	__ __ __ __ __
<i>(a cura dell'ufficio)</i>					

**B<sub>2</sub> - RIFERIMENTO VERTICALE**

Bene complesso	<input type="radio"/>	Bene individuo	<input type="radio"/>
Denominazione: _____			
Numero schede beni componenti		__	Codice livello superiore
Tipologia	<input type="checkbox"/> canonica <input type="checkbox"/> palazzo <input type="checkbox"/> castello <input type="checkbox"/> torre <input type="checkbox"/> bene archeologico <input type="checkbox"/> altro _____		
Pianta	<input type="radio"/> regolare <input type="radio"/> con cortili <input type="radio"/> ad ali aperte <input type="radio"/> lineare <input type="radio"/> altro _____		

**B<sub>3</sub> - LOCALIZZAZIONE GEOGRAFICO AMMINISTRATIVA**

Regione	_____	Codice Istat comune	_____	Indirizzo	_____
Provincia	_____	_____	_____	1 <input type="radio"/> via	_____
Comune	_____	_____	_____	2 <input type="radio"/> corso	_____
Località	_____	_____	_____	3 <input type="radio"/> vicolo	_____
				4 <input type="radio"/> piazza	_____
				5 <input type="radio"/> località	num.civico _____
Sezione censuaria	_____	N° complesso o aggregato	_____	N° edificio	_____
Foglio	_____	Data	_____	Particelle	_____
				Sub.	_____

**B<sub>4</sub> - COORDINATE UTM**

Quadrante	_____	Longitudine Est (x)	__° __'	Latitudine Nord(y)	__° __'	<input type="radio"/> Lettura GPS
-----------	-------	---------------------	---------	--------------------	---------	-----------------------------------

**B<sub>5</sub> - OGGETTO**

Denominazione bene	_____
Denominazione storica	_____
Datazione	anno _____ secolo _____ epoca _____
Ultima trasformazione	_____
Proprietà	_____ ☎ _____
Utilizzatore	_____ ☎ _____

**B<sub>6</sub> – DESTINAZIONE D'USO ATTUALE**

Uso	N° unità d'uso	Utilizzazione spaziale [%]				Utilizzazione temporale			Esposizione	
		>65	30÷65	< 30	0	Continuo	Saltuario	Non utilizzato	N° occupanti	Affollamento
Abitazione	<input type="checkbox"/>	□□□□	○	○	○	○	○	○	□□□□	<input type="checkbox"/>
Commerciale	<input type="checkbox"/>	□□□□	○	○	○	○	○	○	□□□□	<input type="checkbox"/>
Museo	<input type="checkbox"/>	□□□□	○	○	○	○	○	○	□□□□	<input type="checkbox"/>
Uffici	<input type="checkbox"/>	□□□□	○	○	○	○	○	○	□□□□	<input type="checkbox"/>
Servizi	<input type="checkbox"/>	□□□□	○	○	○	○	○	○	□□□□	<input type="checkbox"/>
Strategico	<input type="checkbox"/>	□□□□	○	○	○	○	○	○	□□□□	<input type="checkbox"/>
Altro	<input type="checkbox"/>	□□□□	○	○	○	○	○	○	□□□□	<input type="checkbox"/>

**B<sub>7</sub> – CARATTERISTICHE DEL SITO**

In piano	<input type="checkbox"/>	Su rilievo / su cresta / su vetta	<input type="checkbox"/>	Su riporto	<input type="checkbox"/>	In pendio / su versante	<input type="checkbox"/>	Avvallamento	<input type="checkbox"/>
----------	--------------------------	-----------------------------------	--------------------------	------------	--------------------------	-------------------------	--------------------------	--------------	--------------------------

**B<sub>8</sub> – CONTESTO URBANO E POSIZIONE**

Centro urbano	<input type="checkbox"/>	Periferia urbana	<input type="checkbox"/>	Area industriale - commerciale	<input type="checkbox"/>	Area agricola	<input type="checkbox"/>	Centro storico	<input type="checkbox"/>
Isolato	<input type="checkbox"/>	Connesso con altri edifici	<input type="checkbox"/>	su	□□	lati	Altro	<input type="checkbox"/>	.....

**B<sub>9</sub> – INFRASTRUTTURE**

Accesso pedonale	<input type="checkbox"/>	Rete viaria idonea in relazione al rischio	<input type="checkbox"/>
Accesso carrabile	<input type="checkbox"/>	Parcheggio nelle vicinanze	<input type="checkbox"/>
Accesso con altezza inferiore a 4 metri	<input type="checkbox"/>	Spazi aperti a disposizione	<input type="checkbox"/>
Accesso con mezzi pesanti	<input type="checkbox"/>	Altro	<input type="checkbox"/>

**B<sub>10</sub> – PRESENZA DI RISCHIO**

		RILEVAZIONE DIRETTA	INFORMAZIONI ACQUISITE
Insedimento minacciato da frana	<input type="checkbox"/>	<input type="checkbox"/>	<input type="checkbox"/>
Insedimento in zona alluvionabile	<input type="checkbox"/>	<input type="checkbox"/>	<input type="checkbox"/>
Insedimento soggetto a minacce di tipo industriale	<input type="checkbox"/>	<input type="checkbox"/>	<input type="checkbox"/>
Insedimento soggetto ad altre minacce naturali	<input type="checkbox"/>	<input type="checkbox"/>	<input type="checkbox"/>

**B<sub>11</sub> – TIPOLOGIA DEI BENI ARTISTICI PRESENTI**

TIPOLOGIA	Num.	superficie	TIPOLOGIA	Num.	superficie		
Affreschi	<input type="checkbox"/>	□□	□□□□	Dipinti mobili su vario supporto	<input type="checkbox"/>	□□	□□□□
Mosaici	<input type="checkbox"/>	□□	□□□□	Arredi (soffitti, amboni, pulpito, stali corali)	<input type="checkbox"/>	□□	□□□□
Stucchi	<input type="checkbox"/>	□□	□□□□	Decorazioni plastiche mobili	<input type="checkbox"/>	□□	□□□□
Arazzi	<input type="checkbox"/>	□□	□□□□	Manufatti in carta e pergamena	<input type="checkbox"/>	□□	□□□□
Altari / statue	<input type="checkbox"/>	□□	□□□□	Reperti archeologici	<input type="checkbox"/>	□□	□□□□
Libri / Stampe	<input type="checkbox"/>	□□	□□□□	Altri .....	<input type="checkbox"/>	□□	□□□□

**B<sub>12</sub> – DOCUMENTAZIONE FOTOGRAFICA – Realizzata da .....**

 SI  NO 
**B<sub>13</sub> – COMPILATORE SCHEDA**

Cognome	□□□□□□□□□□□□□□□□□□□□□□	Nome	□□□□□□□□□□□□□□□□□□□□□□
Ente/ufficio di appartenenza	□□□□□□□□□□□□□□□□□□□□□□□□□□□□□□□□□□		
☎	□□□□□□□□□□	E-Mail:	.....

**B<sub>14</sub> - RIFERIMENTO SCHEDA DELLA VULNERABILITA' DEI PALAZZI**

N° Scheda	_____	Data	____/____/____	Ente	_____
-----------	-------	------	----------------	------	-------

**B<sub>15</sub> - STATO DI MANUTENZIONE GENERALE**

	Buono	Discreto	Scadente	Pessimo	Lavori in corso
Strutture verticali	<input type="radio"/>	<input type="radio"/>	<input type="radio"/>	<input type="radio"/>	<input type="checkbox"/>
Strutture orizzontali	<input type="radio"/>	<input type="radio"/>	<input type="radio"/>	<input type="radio"/>	<input type="checkbox"/>
Copertura	<input type="radio"/>	<input type="radio"/>	<input type="radio"/>	<input type="radio"/>	<input type="checkbox"/>

**B<sub>16</sub> - INTERVENTI**

Ampliamento	Sopraelevazione	Manutenzione straordinaria	Consolidamento
<input type="checkbox"/>	<input type="checkbox"/>	<input type="checkbox"/>	<input type="checkbox"/>
.....	.....	.....	.....
.....	.....	.....	.....
.....	.....	.....	.....
.....	.....	.....	.....
.....	.....	.....	.....
.....	.....	.....	.....
.....	.....	.....	.....
.....	.....	.....	.....
.....	.....	.....	.....

**B<sub>17</sub> - REGOLARITA', FORMA PLANIMETRICA E DATI DIMENSIONALI**

	Regolare	Non regolare	FORMA IN PIANTA	<input type="radio"/> rettangolare	<input type="radio"/> rett. allungata	<input type="radio"/> a L
Pianta	<input type="radio"/>	<input type="radio"/>		<input type="radio"/> a C	<input type="radio"/> a corti	<input type="radio"/> altro
Elevazione	<input type="radio"/>	<input type="radio"/>	Presenza di <input type="checkbox"/> porticati <input type="checkbox"/> logge <input type="checkbox"/> cavedii <input type="checkbox"/> atrio			
Disposizione muri interni	<input type="radio"/>	<input type="radio"/>	Discontinuità costruttive e del materiale <input type="checkbox"/>			
Disposizione aperture	<input type="radio"/>	<input type="radio"/>				

DATI DIMENSIONALI	Stimati <input type="radio"/>	rilevati <input type="radio"/>				
Larghezza media	_____	_____	Superficie media in pianta	Altezza media in gronda	Piani fuori terra	
m. _____	m. _____	m <sup>2</sup> . _____	m. _____		_____	
					Piani interrati	
					_____	

**B<sub>18</sub> - EIDOTIPO E SUDDIVISIONE IN ELEMENTI**

SUDDIVISIONE IN AREE					INDIVIDUAZIONE CORPI SCALA E CORPI ANNESSI					INDIVIDUAZIONE COPERTURE									
Area					N° totale corpi scala: _____ N° totale corpi annessi: _____					Copertura									
															Sup.[m <sup>2</sup> ]				
															N° piani				

**B<sub>19</sub> - RILIEVO DEL DANNO AGLI ELEMENTI STRUTTURALI**

TIPOLOGIA MURARIA		DESCRIZIONE
A	PIETRA SQUADRATA	
B	PIETRA SBOZZATA	
C	PIETRA A SPACCO	
D	MATTONI	
E	IRREGOLARE, CIOTTOLI, MISTA	
F	ALTRO	

PARETI PERIMETRALI																			
N° PARETE	TIPOLOGIA E PARAMETRI DIMENSIONALI								DANNO (LIVELLO ED ESTENSIONE)										
	LIBERA	PARZ. LIBERA	IN AGGREGATO	APERTURE			LUNGHEZZA [m]	SPESSORE [m]	TIPOLOGIA MURARIA (A + F di B <sub>19</sub> )	PRESENZA DI CORDOLI / CATENE	PARETI INTERNE ORTOGONALI	D1 LEGGERO			D2 - D3 MEDIO GRAVE		D4 - D5 GRAVISSIMO		NULLO
				uniformi	discontinue	assenti						>2/3	1/3 - 2/3	<1/3	>2/3	1/3 - 2/3	<1/3	>2/3	
	<input type="checkbox"/>	<input type="checkbox"/>	<input type="checkbox"/>	<input type="checkbox"/>	<input type="checkbox"/>	<input type="checkbox"/>				<input type="checkbox"/>	<input type="checkbox"/>	<input type="checkbox"/>	<input type="checkbox"/>	<input type="checkbox"/>	<input type="checkbox"/>	<input type="checkbox"/>	<input type="checkbox"/>	<input type="checkbox"/>	<input type="checkbox"/>
	<input type="checkbox"/>	<input type="checkbox"/>	<input type="checkbox"/>	<input type="checkbox"/>	<input type="checkbox"/>	<input type="checkbox"/>				<input type="checkbox"/>	<input type="checkbox"/>	<input type="checkbox"/>	<input type="checkbox"/>	<input type="checkbox"/>	<input type="checkbox"/>	<input type="checkbox"/>	<input type="checkbox"/>	<input type="checkbox"/>	<input type="checkbox"/>
	<input type="checkbox"/>	<input type="checkbox"/>	<input type="checkbox"/>	<input type="checkbox"/>	<input type="checkbox"/>	<input type="checkbox"/>				<input type="checkbox"/>	<input type="checkbox"/>	<input type="checkbox"/>	<input type="checkbox"/>	<input type="checkbox"/>	<input type="checkbox"/>	<input type="checkbox"/>	<input type="checkbox"/>	<input type="checkbox"/>	<input type="checkbox"/>
	<input type="checkbox"/>	<input type="checkbox"/>	<input type="checkbox"/>	<input type="checkbox"/>	<input type="checkbox"/>	<input type="checkbox"/>				<input type="checkbox"/>	<input type="checkbox"/>	<input type="checkbox"/>	<input type="checkbox"/>	<input type="checkbox"/>	<input type="checkbox"/>	<input type="checkbox"/>	<input type="checkbox"/>	<input type="checkbox"/>	<input type="checkbox"/>
	<input type="checkbox"/>	<input type="checkbox"/>	<input type="checkbox"/>	<input type="checkbox"/>	<input type="checkbox"/>	<input type="checkbox"/>				<input type="checkbox"/>	<input type="checkbox"/>	<input type="checkbox"/>	<input type="checkbox"/>	<input type="checkbox"/>	<input type="checkbox"/>	<input type="checkbox"/>	<input type="checkbox"/>	<input type="checkbox"/>	<input type="checkbox"/>
	<input type="checkbox"/>	<input type="checkbox"/>	<input type="checkbox"/>	<input type="checkbox"/>	<input type="checkbox"/>	<input type="checkbox"/>				<input type="checkbox"/>	<input type="checkbox"/>	<input type="checkbox"/>	<input type="checkbox"/>	<input type="checkbox"/>	<input type="checkbox"/>	<input type="checkbox"/>	<input type="checkbox"/>	<input type="checkbox"/>	<input type="checkbox"/>
	<input type="checkbox"/>	<input type="checkbox"/>	<input type="checkbox"/>	<input type="checkbox"/>	<input type="checkbox"/>	<input type="checkbox"/>				<input type="checkbox"/>	<input type="checkbox"/>	<input type="checkbox"/>	<input type="checkbox"/>	<input type="checkbox"/>	<input type="checkbox"/>	<input type="checkbox"/>	<input type="checkbox"/>	<input type="checkbox"/>	<input type="checkbox"/>
	<input type="checkbox"/>	<input type="checkbox"/>	<input type="checkbox"/>	<input type="checkbox"/>	<input type="checkbox"/>	<input type="checkbox"/>				<input type="checkbox"/>	<input type="checkbox"/>	<input type="checkbox"/>	<input type="checkbox"/>	<input type="checkbox"/>	<input type="checkbox"/>	<input type="checkbox"/>	<input type="checkbox"/>	<input type="checkbox"/>	<input type="checkbox"/>
	<input type="checkbox"/>	<input type="checkbox"/>	<input type="checkbox"/>	<input type="checkbox"/>	<input type="checkbox"/>	<input type="checkbox"/>				<input type="checkbox"/>	<input type="checkbox"/>	<input type="checkbox"/>	<input type="checkbox"/>	<input type="checkbox"/>	<input type="checkbox"/>	<input type="checkbox"/>	<input type="checkbox"/>	<input type="checkbox"/>	<input type="checkbox"/>

PORTICATI / LOGGE / ATRI																			
N° PARETE	TIPOLOGIA E PARAMETRI DIMENSIONALI						DANNO (LIVELLO ED ESTENSIONE)												
	PIANI	LUNGHEZZA [m]	TIPOLOGIA STRUTTURALE				PRESENZA DI CATENE	D1 LEGGERO			D2 - D3 MEDIO GRAVE		D4 - D5 GRAVISSIMO		NULLO				
			muratura	c.a.	legno	acciaio		>2/3	1/3 - 2/3	<1/3	>2/3	1/3 - 2/3	<1/3	>2/3		1/3 - 2/3	<1/3		
			<input type="checkbox"/>	<input type="checkbox"/>	<input type="checkbox"/>	<input type="checkbox"/>	<input type="checkbox"/>	<input type="checkbox"/>	<input type="checkbox"/>	<input type="checkbox"/>	<input type="checkbox"/>	<input type="checkbox"/>	<input type="checkbox"/>	<input type="checkbox"/>	<input type="checkbox"/>	<input type="checkbox"/>	<input type="checkbox"/>	<input type="checkbox"/>	<input type="checkbox"/>
			<input type="checkbox"/>	<input type="checkbox"/>	<input type="checkbox"/>	<input type="checkbox"/>	<input type="checkbox"/>	<input type="checkbox"/>	<input type="checkbox"/>	<input type="checkbox"/>	<input type="checkbox"/>	<input type="checkbox"/>	<input type="checkbox"/>	<input type="checkbox"/>	<input type="checkbox"/>	<input type="checkbox"/>	<input type="checkbox"/>	<input type="checkbox"/>	<input type="checkbox"/>
			<input type="checkbox"/>	<input type="checkbox"/>	<input type="checkbox"/>	<input type="checkbox"/>	<input type="checkbox"/>	<input type="checkbox"/>	<input type="checkbox"/>	<input type="checkbox"/>	<input type="checkbox"/>	<input type="checkbox"/>	<input type="checkbox"/>	<input type="checkbox"/>	<input type="checkbox"/>	<input type="checkbox"/>	<input type="checkbox"/>	<input type="checkbox"/>	<input type="checkbox"/>
			<input type="checkbox"/>	<input type="checkbox"/>	<input type="checkbox"/>	<input type="checkbox"/>	<input type="checkbox"/>	<input type="checkbox"/>	<input type="checkbox"/>	<input type="checkbox"/>	<input type="checkbox"/>	<input type="checkbox"/>	<input type="checkbox"/>	<input type="checkbox"/>	<input type="checkbox"/>	<input type="checkbox"/>	<input type="checkbox"/>	<input type="checkbox"/>	<input type="checkbox"/>
			<input type="checkbox"/>	<input type="checkbox"/>	<input type="checkbox"/>	<input type="checkbox"/>	<input type="checkbox"/>	<input type="checkbox"/>	<input type="checkbox"/>	<input type="checkbox"/>	<input type="checkbox"/>	<input type="checkbox"/>	<input type="checkbox"/>	<input type="checkbox"/>	<input type="checkbox"/>	<input type="checkbox"/>	<input type="checkbox"/>	<input type="checkbox"/>	<input type="checkbox"/>
			<input type="checkbox"/>	<input type="checkbox"/>	<input type="checkbox"/>	<input type="checkbox"/>	<input type="checkbox"/>	<input type="checkbox"/>	<input type="checkbox"/>	<input type="checkbox"/>	<input type="checkbox"/>	<input type="checkbox"/>	<input type="checkbox"/>	<input type="checkbox"/>	<input type="checkbox"/>	<input type="checkbox"/>	<input type="checkbox"/>	<input type="checkbox"/>	<input type="checkbox"/>
			<input type="checkbox"/>	<input type="checkbox"/>	<input type="checkbox"/>	<input type="checkbox"/>	<input type="checkbox"/>	<input type="checkbox"/>	<input type="checkbox"/>	<input type="checkbox"/>	<input type="checkbox"/>	<input type="checkbox"/>	<input type="checkbox"/>	<input type="checkbox"/>	<input type="checkbox"/>	<input type="checkbox"/>	<input type="checkbox"/>	<input type="checkbox"/>	<input type="checkbox"/>
			<input type="checkbox"/>	<input type="checkbox"/>	<input type="checkbox"/>	<input type="checkbox"/>	<input type="checkbox"/>	<input type="checkbox"/>	<input type="checkbox"/>	<input type="checkbox"/>	<input type="checkbox"/>	<input type="checkbox"/>	<input type="checkbox"/>	<input type="checkbox"/>	<input type="checkbox"/>	<input type="checkbox"/>	<input type="checkbox"/>	<input type="checkbox"/>	<input type="checkbox"/>

PARETI INTERNE																			
N° AREA	TIPOLOGIA E PARAMETRI DIMENSIONALI					DANNO (LIVELLO ED ESTENSIONE)													
	LUNGHEZZA [m]		SPESSORE [m]		TIPOLOGIA MURARIA (A + F di B <sub>19</sub> )	D1 LEGGERO			D2 - D3 MEDIO GRAVE		D4 - D5 GRAVISSIMO		NULLO						
	x	y	x	y		>2/3	1/3 - 2/3	<1/3	>2/3	1/3 - 2/3	<1/3	>2/3		1/3 - 2/3	<1/3				
						<input type="checkbox"/>	<input type="checkbox"/>	<input type="checkbox"/>	<input type="checkbox"/>	<input type="checkbox"/>	<input type="checkbox"/>	<input type="checkbox"/>	<input type="checkbox"/>	<input type="checkbox"/>	<input type="checkbox"/>	<input type="checkbox"/>	<input type="checkbox"/>	<input type="checkbox"/>	<input type="checkbox"/>
						<input type="checkbox"/>	<input type="checkbox"/>	<input type="checkbox"/>	<input type="checkbox"/>	<input type="checkbox"/>	<input type="checkbox"/>	<input type="checkbox"/>	<input type="checkbox"/>	<input type="checkbox"/>	<input type="checkbox"/>	<input type="checkbox"/>	<input type="checkbox"/>	<input type="checkbox"/>	<input type="checkbox"/>
						<input type="checkbox"/>	<input type="checkbox"/>	<input type="checkbox"/>	<input type="checkbox"/>	<input type="checkbox"/>	<input type="checkbox"/>	<input type="checkbox"/>	<input type="checkbox"/>	<input type="checkbox"/>	<input type="checkbox"/>	<input type="checkbox"/>	<input type="checkbox"/>	<input type="checkbox"/>	<input type="checkbox"/>
						<input type="checkbox"/>	<input type="checkbox"/>	<input type="checkbox"/>	<input type="checkbox"/>	<input type="checkbox"/>	<input type="checkbox"/>	<input type="checkbox"/>	<input type="checkbox"/>	<input type="checkbox"/>	<input type="checkbox"/>	<input type="checkbox"/>	<input type="checkbox"/>	<input type="checkbox"/>	<input type="checkbox"/>

CORPI SCALA																	
N°	N° AREA	TIPOLOGIA E PARAMETRI DIMENSIONALI						DANNO (LIVELLO ED ESTENSIONE)									
		PIANI	SUPERFICIE [m <sup>2</sup> ]	TIPOLOGIA STRUTTURALE				D1 LEGGERO			D2 - D3 MEDIO GRAVE			D4 - D5 GRAVISSIMO			NULLO
				muratura	c.a.	legno	acciaio	>2/3	1/3 - 2/3	<1/3	>2/3	1/3 - 2/3	<1/3	>2/3	1/3 - 2/3	<1/3	
				<input type="checkbox"/>	<input type="checkbox"/>	<input type="checkbox"/>	<input type="checkbox"/>	<input type="checkbox"/>	<input type="checkbox"/>	<input type="checkbox"/>	<input type="checkbox"/>	<input type="checkbox"/>	<input type="checkbox"/>	<input type="checkbox"/>	<input type="checkbox"/>	<input type="checkbox"/>	<input type="checkbox"/>
				<input type="checkbox"/>	<input type="checkbox"/>	<input type="checkbox"/>	<input type="checkbox"/>	<input type="checkbox"/>	<input type="checkbox"/>	<input type="checkbox"/>	<input type="checkbox"/>	<input type="checkbox"/>	<input type="checkbox"/>	<input type="checkbox"/>	<input type="checkbox"/>	<input type="checkbox"/>	<input type="checkbox"/>
				<input type="checkbox"/>	<input type="checkbox"/>	<input type="checkbox"/>	<input type="checkbox"/>	<input type="checkbox"/>	<input type="checkbox"/>	<input type="checkbox"/>	<input type="checkbox"/>	<input type="checkbox"/>	<input type="checkbox"/>	<input type="checkbox"/>	<input type="checkbox"/>	<input type="checkbox"/>	<input type="checkbox"/>
				<input type="checkbox"/>	<input type="checkbox"/>	<input type="checkbox"/>	<input type="checkbox"/>	<input type="checkbox"/>	<input type="checkbox"/>	<input type="checkbox"/>	<input type="checkbox"/>	<input type="checkbox"/>	<input type="checkbox"/>	<input type="checkbox"/>	<input type="checkbox"/>	<input type="checkbox"/>	<input type="checkbox"/>
				<input type="checkbox"/>	<input type="checkbox"/>	<input type="checkbox"/>	<input type="checkbox"/>	<input type="checkbox"/>	<input type="checkbox"/>	<input type="checkbox"/>	<input type="checkbox"/>	<input type="checkbox"/>	<input type="checkbox"/>	<input type="checkbox"/>	<input type="checkbox"/>	<input type="checkbox"/>	<input type="checkbox"/>

ORIZZONTAMENTI																	
N° AREA	TIPOLOGIA E PARAMETRI DIMENSIONALI						DANNO (LIVELLO ED ESTENSIONE)										
	SUPERFICIE [m <sup>2</sup> ]	H INTERPIANO [m]	TIPOLOGIA [%]				D1 LEGGERO			D2 - D3 MEDIO GRAVE			D4 - D5 GRAVISSIMO			NULLO	
			legno	volte	c.a.	acciaio	>2/3	1/3 - 2/3	<1/3	>2/3	1/3 - 2/3	<1/3	>2/3	1/3 - 2/3	<1/3		
										<input type="checkbox"/>	<input type="checkbox"/>	<input type="checkbox"/>	<input type="checkbox"/>	<input type="checkbox"/>	<input type="checkbox"/>	<input type="checkbox"/>	<input type="checkbox"/>
										<input type="checkbox"/>	<input type="checkbox"/>	<input type="checkbox"/>	<input type="checkbox"/>	<input type="checkbox"/>	<input type="checkbox"/>	<input type="checkbox"/>	<input type="checkbox"/>
										<input type="checkbox"/>	<input type="checkbox"/>	<input type="checkbox"/>	<input type="checkbox"/>	<input type="checkbox"/>	<input type="checkbox"/>	<input type="checkbox"/>	<input type="checkbox"/>
										<input type="checkbox"/>	<input type="checkbox"/>	<input type="checkbox"/>	<input type="checkbox"/>	<input type="checkbox"/>	<input type="checkbox"/>	<input type="checkbox"/>	<input type="checkbox"/>
										<input type="checkbox"/>	<input type="checkbox"/>	<input type="checkbox"/>	<input type="checkbox"/>	<input type="checkbox"/>	<input type="checkbox"/>	<input type="checkbox"/>	<input type="checkbox"/>

COPERTURE																	
N°	TIPOLOGIA E PARAMETRI DIMENSIONALI						DANNO (LIVELLO ED ESTENSIONE)										
	SUPERFICIE [m <sup>2</sup> ]	TIPOLOGIA			SPINGENTE		DESCRIZIONE	D1 LEGGERO			D2 - D3 MEDIO GRAVE			D4 - D5 GRAVISSIMO			NULLO
		c.a.	legno	acciaio	si	no		>2/3	1/3 - 2/3	<1/3	>2/3	1/3 - 2/3	<1/3	>2/3	1/3 - 2/3	<1/3	
		<input type="checkbox"/>	<input type="checkbox"/>	<input type="checkbox"/>	<input type="checkbox"/>	<input type="checkbox"/>				<input type="checkbox"/>	<input type="checkbox"/>	<input type="checkbox"/>	<input type="checkbox"/>	<input type="checkbox"/>	<input type="checkbox"/>	<input type="checkbox"/>	<input type="checkbox"/>
		<input type="checkbox"/>	<input type="checkbox"/>	<input type="checkbox"/>	<input type="checkbox"/>	<input type="checkbox"/>				<input type="checkbox"/>	<input type="checkbox"/>	<input type="checkbox"/>	<input type="checkbox"/>	<input type="checkbox"/>	<input type="checkbox"/>	<input type="checkbox"/>	<input type="checkbox"/>
		<input type="checkbox"/>	<input type="checkbox"/>	<input type="checkbox"/>	<input type="checkbox"/>	<input type="checkbox"/>				<input type="checkbox"/>	<input type="checkbox"/>	<input type="checkbox"/>	<input type="checkbox"/>	<input type="checkbox"/>	<input type="checkbox"/>	<input type="checkbox"/>	<input type="checkbox"/>
		<input type="checkbox"/>	<input type="checkbox"/>	<input type="checkbox"/>	<input type="checkbox"/>	<input type="checkbox"/>				<input type="checkbox"/>	<input type="checkbox"/>	<input type="checkbox"/>	<input type="checkbox"/>	<input type="checkbox"/>	<input type="checkbox"/>	<input type="checkbox"/>	<input type="checkbox"/>

BALCONI / ELEMENTI AGGETTANTI											
N° TOTALE	DANNO (LIVELLO ED ESTENSIONE)									NULLO	
	D4 - D5 GRAVISSIMO			D2 - D3 MEDIO GRAVE			D1 LEGGERO				
	>2/3	1/3 - 2/3	<1/3	>2/3	1/3 - 2/3	<1/3	>2/3	1/3 - 2/3	<1/3		
	<input type="checkbox"/>	<input type="checkbox"/>	<input type="checkbox"/>	<input type="checkbox"/>	<input type="checkbox"/>	<input type="checkbox"/>	<input type="checkbox"/>	<input type="checkbox"/>	<input type="checkbox"/>	<input type="checkbox"/>	<input type="checkbox"/>

ELEMENTI SVETTANTI											
N° TOTALE	DANNO (LIVELLO ED ESTENSIONE)									NULLO	
	D1 LEGGERO			D2 - D3 MEDIO GRAVE			D4 - D5 GRAVISSIMO				
	>2/3	1/3 - 2/3	<1/3	>2/3	1/3 - 2/3	<1/3	>2/3	1/3 - 2/3	<1/3		
	<input type="checkbox"/>	<input type="checkbox"/>	<input type="checkbox"/>	<input type="checkbox"/>	<input type="checkbox"/>	<input type="checkbox"/>	<input type="checkbox"/>	<input type="checkbox"/>	<input type="checkbox"/>	<input type="checkbox"/>	<input type="checkbox"/>

CORPI ANNESSI													
N°	TIPOLOGIA E PARAMETRI DIMENSIONALI			DANNO (LIVELLO ED ESTENSIONE)									
	SUPERFICIE [m <sup>2</sup> ]	PRESENZA DI CATENE	D1 LEGGERO			D2 - D3 MEDIO GRAVE			D4 - D5 GRAVISSIMO			NULLO	
			>2/3	1/3 - 2/3	<1/3	>2/3	1/3 - 2/3	<1/3	>2/3	1/3 - 2/3	<1/3		
		<input type="checkbox"/>	<input type="checkbox"/>	<input type="checkbox"/>	<input type="checkbox"/>	<input type="checkbox"/>	<input type="checkbox"/>	<input type="checkbox"/>	<input type="checkbox"/>	<input type="checkbox"/>	<input type="checkbox"/>	<input type="checkbox"/>	<input type="checkbox"/>
		<input type="checkbox"/>	<input type="checkbox"/>	<input type="checkbox"/>	<input type="checkbox"/>	<input type="checkbox"/>	<input type="checkbox"/>	<input type="checkbox"/>	<input type="checkbox"/>	<input type="checkbox"/>	<input type="checkbox"/>	<input type="checkbox"/>	<input type="checkbox"/>
		<input type="checkbox"/>	<input type="checkbox"/>	<input type="checkbox"/>	<input type="checkbox"/>	<input type="checkbox"/>	<input type="checkbox"/>	<input type="checkbox"/>	<input type="checkbox"/>	<input type="checkbox"/>	<input type="checkbox"/>	<input type="checkbox"/>	<input type="checkbox"/>
		<input type="checkbox"/>	<input type="checkbox"/>	<input type="checkbox"/>	<input type="checkbox"/>	<input type="checkbox"/>	<input type="checkbox"/>	<input type="checkbox"/>	<input type="checkbox"/>	<input type="checkbox"/>	<input type="checkbox"/>	<input type="checkbox"/>	<input type="checkbox"/>

**B<sub>20</sub> - RILIEVO DEL DANNO AGLI ELEMENTI NON STRUTTURALI**

I	COMIGNOLI	II	CORNICIONI	III	STATUE O AGGETTI	IV	RIVESTIMENTI O CONTROSOFFITTI RECENTI
V	RETE IDRICA , FOGNARIA O TERMOIDRAULICA	VI	RETE ELETTRICA O DEL GAS	VII	ALTRO.....	VIII	ALTRO.....

**LIVELLO DI DANNO**

0 - □□□□□ assenza di danno    1 - ■□□□□ danno lieve    2 - ■■□□□ danno moderato  
 3 - ■■■□□ danno grave    4 - ■■■■□ danno molto grave    5 - ■■■■■ crollo

**IDENTIFICAZIONE DEL DANNO**

A - danno sismico  
 B - danno pregresso  
 C - aggravamento

ELEMENTI DANNEGGIATI	Livello di danno	p	LOCALIZZAZIONE	PROVVEDIMENTI DI P.I. SUGGERITI			
				PUNTELLAMENTI	RIPARAZIONE	TRANSENNATURE	ALTRO
	□ □ □ □ □	┘		<input type="checkbox"/>	<input type="checkbox"/>	<input type="checkbox"/>	<input type="checkbox"/>
	□ □ □ □ □	┘		<input type="checkbox"/>	<input type="checkbox"/>	<input type="checkbox"/>	<input type="checkbox"/>
	□ □ □ □ □	┘		<input type="checkbox"/>	<input type="checkbox"/>	<input type="checkbox"/>	<input type="checkbox"/>
	□ □ □ □ □	┘		<input type="checkbox"/>	<input type="checkbox"/>	<input type="checkbox"/>	<input type="checkbox"/>
	□ □ □ □ □	┘		<input type="checkbox"/>	<input type="checkbox"/>	<input type="checkbox"/>	<input type="checkbox"/>

NOTE.....

**B<sub>21</sub> - PERICOLO ESTERNO**

CAUSA POTENZIALE	PERICOLO SU		PROVVEDIMENTI DI P.I. SUGGERITI	
	EDIFICIO	VIA D'ACCESSO	DIVIETO DI ACCESSO	TRANSENNE E PROTEZIONE PASSAGGI
CROLLI O CADUTE DA ALTRE COSTRUZIONI	<input type="checkbox"/>	<input type="checkbox"/>	<input type="checkbox"/>	<input type="checkbox"/>
ROTTURA DI RETI DI SERVIZI/DISSESTI	<input type="checkbox"/>	<input type="checkbox"/>	<input type="checkbox"/>	<input type="checkbox"/>

**B<sub>22</sub> - DISSESTI DI VERSANTE O DEL TERRENO DI FONDAZIONE**

	ASSENTI	PREESISTENTI	GENERATI DAL SISMA	ACUITI DAL SISMA
VERSANTI INCOMBENTI	○	○	○	○
TERRENO DI FONDAZIONE	○	○	○	○

**B<sub>23</sub> - MECCANISMI DI COLLASSO STRUTTURALI**

TIPOLOGIA	n	CODICE	MECCANISMO
PARETI PERIMETRALI	┘┘	M1	<input type="checkbox"/> RIBALTAMENTO DELLE PARETI
		M2	<input type="checkbox"/> INSTABILITÀ VERTICALE DELLE PARETI
		M3	<input type="checkbox"/> ROTTURA A FLESSIONE DELLE PARETI
		M4	<input type="checkbox"/> RIBALTAMENTO DEL CANTONALE
		M5	<input type="checkbox"/> TAGLIO NELLE PARETI ESTERNE: MASCHI
		M6	<input type="checkbox"/> TAGLIO NELLE PARETI ESTERNE: ARCHITRAVI E MURATURA SOPRASTANTE
PARETI INTERNE	2x┘┘	M7	<input type="checkbox"/> TAGLIO NELLE PARETI INTERNE
GLOBALE	<input checked="" type="checkbox"/>	M8	<input type="checkbox"/> SCORRIMENTO DI PIANO
PORTICATI / LOGGE	<input type="checkbox"/>	M9	<input type="checkbox"/> DANNO AI PORTICATI / LOGGE
ORIZZONTAMENTI	┘┘	M10	<input type="checkbox"/> SFILAMENTO TESTA DELLE TRAVI E/O MARTELLAMENTO
		M11	<input type="checkbox"/> COLLASSI LOCALI DELL'IMPALCATO O DELLA VOLTA
		M12	<input type="checkbox"/> DANNO ALLE VOLTE PER ROTAZIONE DELLE IMPOSTE
		M13	<input type="checkbox"/> DANNO ALLE VOLTE PER DEFORMAZIONE DI PIANO
SCALE	┘┘	M14	<input type="checkbox"/> DANNO ALLE SCALE
COPERTURE	┘┘	M15	<input type="checkbox"/> DANNO NEGLI ELEMENTI DI COPERTURA
		M16	<input type="checkbox"/> DANNO AL MANTO DI COPERTURA
		M17	<input type="checkbox"/> RIBALTAMENTO DELLE FASCE SOTTOTETTO E TIMPANO
ELEMENTI AGGETTANTI / SVETTANTI	<input type="checkbox"/>	M18	<input type="checkbox"/> DANNO AGLI ELEMENTI AGGETTANTI / SVETTANTI
COLLASSI LOCALI	<input type="checkbox"/>	M19	<input type="checkbox"/> COLLASSI LOCALI PER IRREGOLARITÀ COSTRUTTIVE E DEL MATERIALE
INTERAZIONI	┘┘	M20	<input type="checkbox"/> DANNO PER IRREGOLARITÀ DI FORMA
		M21	<input type="checkbox"/> DANNO NEI CORPI ANNESSI
		M22	<input checked="" type="checkbox"/> CEDIMENTO DI FONDAZIONI
ALTRO	<input type="checkbox"/>	M23	<input type="checkbox"/> .....
		M24	<input type="checkbox"/> .....

**B<sub>23.1</sub> - LIVELLO DI ATTIVAZIONE RISPETTO AL COLLASSO**

0 - □□□□□ assente     1 - ■□□□□ lieve     2 - ■■□□□ moderato  
 3 - ■■■□□ grave     4 - ■■■■□ molto grave     5 - ■■■■■ crollo

**IDENTIFICAZIONE DEL LIVELLO DI ATTIVAZIONE**

A - danno sismico  
 B - danno pregresso  
 C - aggravamento

N° PROGRESSIVO	CODICE MECCANISMO	ARE A	PIANI	ELEMENTI INTERESSATI	SECONDAIO	LIVELLO DI ATTIVAZIONE RISPETTO AL COLLASSO	P	RISCHIO			PROVVEDIMENTI DI P.I. SUGGERITI									
								BASSO	BASSO CON PROVVEDIMENTI	ALTO	CERCHIATURE TIRANTI	PUNTELLI	TAMPONATURE	RIPARAZIONI	RIMOZIONI	TRANSENNATURE	PROTEZIONI	ALTRO		
					<input type="checkbox"/>	□□□□□	<input type="checkbox"/>	<input type="checkbox"/>	<input type="checkbox"/>	<input type="checkbox"/>	<input type="checkbox"/>	<input type="checkbox"/>	<input type="checkbox"/>	<input type="checkbox"/>	<input type="checkbox"/>	<input type="checkbox"/>	<input type="checkbox"/>	<input type="checkbox"/>	<input type="checkbox"/>	<input type="checkbox"/>
					<input type="checkbox"/>	■□□□□	<input type="checkbox"/>	<input type="checkbox"/>	<input type="checkbox"/>	<input type="checkbox"/>	<input type="checkbox"/>	<input type="checkbox"/>	<input type="checkbox"/>	<input type="checkbox"/>	<input type="checkbox"/>	<input type="checkbox"/>	<input type="checkbox"/>	<input type="checkbox"/>	<input type="checkbox"/>	<input type="checkbox"/>
					<input type="checkbox"/>	■■□□□	<input type="checkbox"/>	<input type="checkbox"/>	<input type="checkbox"/>	<input type="checkbox"/>	<input type="checkbox"/>	<input type="checkbox"/>	<input type="checkbox"/>	<input type="checkbox"/>	<input type="checkbox"/>	<input type="checkbox"/>	<input type="checkbox"/>	<input type="checkbox"/>	<input type="checkbox"/>	<input type="checkbox"/>
					<input type="checkbox"/>	■■■□□	<input type="checkbox"/>	<input type="checkbox"/>	<input type="checkbox"/>	<input type="checkbox"/>	<input type="checkbox"/>	<input type="checkbox"/>	<input type="checkbox"/>	<input type="checkbox"/>	<input type="checkbox"/>	<input type="checkbox"/>	<input type="checkbox"/>	<input type="checkbox"/>	<input type="checkbox"/>	<input type="checkbox"/>
					<input type="checkbox"/>	■■■■□	<input type="checkbox"/>	<input type="checkbox"/>	<input type="checkbox"/>	<input type="checkbox"/>	<input type="checkbox"/>	<input type="checkbox"/>	<input type="checkbox"/>	<input type="checkbox"/>	<input type="checkbox"/>	<input type="checkbox"/>	<input type="checkbox"/>	<input type="checkbox"/>	<input type="checkbox"/>	<input type="checkbox"/>
					<input type="checkbox"/>	■■■■■	<input type="checkbox"/>	<input type="checkbox"/>	<input type="checkbox"/>	<input type="checkbox"/>	<input type="checkbox"/>	<input type="checkbox"/>	<input type="checkbox"/>	<input type="checkbox"/>	<input type="checkbox"/>	<input type="checkbox"/>	<input type="checkbox"/>	<input type="checkbox"/>	<input type="checkbox"/>	<input type="checkbox"/>
					<input type="checkbox"/>	□□□□□	<input type="checkbox"/>	<input type="checkbox"/>	<input type="checkbox"/>	<input type="checkbox"/>	<input type="checkbox"/>	<input type="checkbox"/>	<input type="checkbox"/>	<input type="checkbox"/>	<input type="checkbox"/>	<input type="checkbox"/>	<input type="checkbox"/>	<input type="checkbox"/>	<input type="checkbox"/>	<input type="checkbox"/>
					<input type="checkbox"/>	■□□□□	<input type="checkbox"/>	<input type="checkbox"/>	<input type="checkbox"/>	<input type="checkbox"/>	<input type="checkbox"/>	<input type="checkbox"/>	<input type="checkbox"/>	<input type="checkbox"/>	<input type="checkbox"/>	<input type="checkbox"/>	<input type="checkbox"/>	<input type="checkbox"/>	<input type="checkbox"/>	<input type="checkbox"/>
					<input type="checkbox"/>	■■□□□	<input type="checkbox"/>	<input type="checkbox"/>	<input type="checkbox"/>	<input type="checkbox"/>	<input type="checkbox"/>	<input type="checkbox"/>	<input type="checkbox"/>	<input type="checkbox"/>	<input type="checkbox"/>	<input type="checkbox"/>	<input type="checkbox"/>	<input type="checkbox"/>	<input type="checkbox"/>	<input type="checkbox"/>
					<input type="checkbox"/>	■■■□□	<input type="checkbox"/>	<input type="checkbox"/>	<input type="checkbox"/>	<input type="checkbox"/>	<input type="checkbox"/>	<input type="checkbox"/>	<input type="checkbox"/>	<input type="checkbox"/>	<input type="checkbox"/>	<input type="checkbox"/>	<input type="checkbox"/>	<input type="checkbox"/>	<input type="checkbox"/>	<input type="checkbox"/>
					<input type="checkbox"/>	■■■■□	<input type="checkbox"/>	<input type="checkbox"/>	<input type="checkbox"/>	<input type="checkbox"/>	<input type="checkbox"/>	<input type="checkbox"/>	<input type="checkbox"/>	<input type="checkbox"/>	<input type="checkbox"/>	<input type="checkbox"/>	<input type="checkbox"/>	<input type="checkbox"/>	<input type="checkbox"/>	<input type="checkbox"/>
					<input type="checkbox"/>	■■■■■	<input type="checkbox"/>	<input type="checkbox"/>	<input type="checkbox"/>	<input type="checkbox"/>	<input type="checkbox"/>	<input type="checkbox"/>	<input type="checkbox"/>	<input type="checkbox"/>	<input type="checkbox"/>	<input type="checkbox"/>	<input type="checkbox"/>	<input type="checkbox"/>	<input type="checkbox"/>	<input type="checkbox"/>
					<input type="checkbox"/>	□□□□□	<input type="checkbox"/>	<input type="checkbox"/>	<input type="checkbox"/>	<input type="checkbox"/>	<input type="checkbox"/>	<input type="checkbox"/>	<input type="checkbox"/>	<input type="checkbox"/>	<input type="checkbox"/>	<input type="checkbox"/>	<input type="checkbox"/>	<input type="checkbox"/>	<input type="checkbox"/>	<input type="checkbox"/>
					<input type="checkbox"/>	■□□□□	<input type="checkbox"/>	<input type="checkbox"/>	<input type="checkbox"/>	<input type="checkbox"/>	<input type="checkbox"/>	<input type="checkbox"/>	<input type="checkbox"/>	<input type="checkbox"/>	<input type="checkbox"/>	<input type="checkbox"/>	<input type="checkbox"/>	<input type="checkbox"/>	<input type="checkbox"/>	<input type="checkbox"/>
					<input type="checkbox"/>	■■□□□	<input type="checkbox"/>	<input type="checkbox"/>	<input type="checkbox"/>	<input type="checkbox"/>	<input type="checkbox"/>	<input type="checkbox"/>	<input type="checkbox"/>	<input type="checkbox"/>	<input type="checkbox"/>	<input type="checkbox"/>	<input type="checkbox"/>	<input type="checkbox"/>	<input type="checkbox"/>	<input type="checkbox"/>
					<input type="checkbox"/>	■■■□□	<input type="checkbox"/>	<input type="checkbox"/>	<input type="checkbox"/>	<input type="checkbox"/>	<input type="checkbox"/>	<input type="checkbox"/>	<input type="checkbox"/>	<input type="checkbox"/>	<input type="checkbox"/>	<input type="checkbox"/>	<input type="checkbox"/>	<input type="checkbox"/>	<input type="checkbox"/>	<input type="checkbox"/>
					<input type="checkbox"/>	■■■■□	<input type="checkbox"/>	<input type="checkbox"/>	<input type="checkbox"/>	<input type="checkbox"/>	<input type="checkbox"/>	<input type="checkbox"/>	<input type="checkbox"/>	<input type="checkbox"/>	<input type="checkbox"/>	<input type="checkbox"/>	<input type="checkbox"/>	<input type="checkbox"/>	<input type="checkbox"/>	<input type="checkbox"/>
					<input type="checkbox"/>	■■■■■	<input type="checkbox"/>	<input type="checkbox"/>	<input type="checkbox"/>	<input type="checkbox"/>	<input type="checkbox"/>	<input type="checkbox"/>	<input type="checkbox"/>	<input type="checkbox"/>	<input type="checkbox"/>	<input type="checkbox"/>	<input type="checkbox"/>	<input type="checkbox"/>	<input type="checkbox"/>	<input type="checkbox"/>
					<input type="checkbox"/>	□□□□□	<input type="checkbox"/>	<input type="checkbox"/>	<input type="checkbox"/>	<input type="checkbox"/>	<input type="checkbox"/>	<input type="checkbox"/>	<input type="checkbox"/>	<input type="checkbox"/>	<input type="checkbox"/>	<input type="checkbox"/>	<input type="checkbox"/>	<input type="checkbox"/>	<input type="checkbox"/>	<input type="checkbox"/>
					<input type="checkbox"/>	■□□□□	<input type="checkbox"/>	<input type="checkbox"/>	<input type="checkbox"/>	<input type="checkbox"/>	<input type="checkbox"/>	<input type="checkbox"/>	<input type="checkbox"/>	<input type="checkbox"/>	<input type="checkbox"/>	<input type="checkbox"/>	<input type="checkbox"/>	<input type="checkbox"/>	<input type="checkbox"/>	<input type="checkbox"/>
					<input type="checkbox"/>	■■□□□	<input type="checkbox"/>	<input type="checkbox"/>	<input type="checkbox"/>	<input type="checkbox"/>	<input type="checkbox"/>	<input type="checkbox"/>	<input type="checkbox"/>	<input type="checkbox"/>	<input type="checkbox"/>	<input type="checkbox"/>	<input type="checkbox"/>	<input type="checkbox"/>	<input type="checkbox"/>	<input type="checkbox"/>
					<input type="checkbox"/>	■■■□□	<input type="checkbox"/>	<input type="checkbox"/>	<input type="checkbox"/>	<input type="checkbox"/>	<input type="checkbox"/>	<input type="checkbox"/>	<input type="checkbox"/>	<input type="checkbox"/>	<input type="checkbox"/>	<input type="checkbox"/>	<input type="checkbox"/>	<input type="checkbox"/>	<input type="checkbox"/>	<input type="checkbox"/>
					<input type="checkbox"/>	■■■■□	<input type="checkbox"/>	<input type="checkbox"/>	<input type="checkbox"/>	<input type="checkbox"/>	<input type="checkbox"/>	<input type="checkbox"/>	<input type="checkbox"/>	<input type="checkbox"/>	<input type="checkbox"/>	<input type="checkbox"/>	<input type="checkbox"/>	<input type="checkbox"/>	<input type="checkbox"/>	<input type="checkbox"/>
					<input type="checkbox"/>	■■■■■	<input type="checkbox"/>	<input type="checkbox"/>	<input type="checkbox"/>	<input type="checkbox"/>	<input type="checkbox"/>	<input type="checkbox"/>	<input type="checkbox"/>	<input type="checkbox"/>	<input type="checkbox"/>	<input type="checkbox"/>	<input type="checkbox"/>	<input type="checkbox"/>	<input type="checkbox"/>	<input type="checkbox"/>
					<input type="checkbox"/>	□□□□□	<input type="checkbox"/>	<input type="checkbox"/>	<input type="checkbox"/>	<input type="checkbox"/>	<input type="checkbox"/>	<input type="checkbox"/>	<input type="checkbox"/>	<input type="checkbox"/>	<input type="checkbox"/>	<input type="checkbox"/>	<input type="checkbox"/>	<input type="checkbox"/>	<input type="checkbox"/>	<input type="checkbox"/>

**B<sub>23.2</sub> - INDICE DI DANNO**

n = <input type="text"/>	d = <input type="text"/>	$i_d = d / 5n = , $
(numero dei meccanismi possibili)	(somma dei livelli di attivazione nei meccanismi primari)	

**B<sub>24</sub> - AGIBILITA'**

Agibile <input type="radio"/>	Inagibile <input type="radio"/>
-------------------------------	---------------------------------

Parzialmente Agibile <input type="radio"/>	Agibile con Provvedimenti <input type="radio"/>	Temporaneamente Inagibile <input type="radio"/>	Inagibile per cause Esterne <input type="radio"/>
Indicare le parti agibili ..... ..... ..... .....	Segnalare i provvedimenti ..... ..... ..... .....	<input type="checkbox"/> Verifica più accurata <input type="checkbox"/> Si consiglia visita di esperti <input type="checkbox"/> Altro ..... ..... .....	Indicare le cause esterne ..... ..... .....

**B<sub>25</sub> - UNITA' IMMOBILIARI INAGIBILI, FAMIGLIE E PERSONE EVACUATE**

Unità immobiliari inagibili     _ _ _ _	Nuclei familiari evacuati     _ _ _ _	N° persone evacuate     _ _ _ _
---	---------------------------------------	---------------------------------

**B<sub>26</sub> - TIPO DI VISITA**

Completa <input type="radio"/>	Parziale <input type="radio"/>	Solo dall'esterno <input type="radio"/>	Motivi ostativi .....
--------------------------------	--------------------------------	---	-----------------------

**B<sub>27</sub> - NOTE SULL'AGIBILITA' ED I PROVVEDIMENTI DI P.I.**

.....

.....

.....

.....

.....

.....

.....

.....

.....

.....

.....

.....

.....

.....

.....

.....

.....

.....

.....

.....

.....

.....

.....

**B<sub>28</sub> - DANNI ALL'APPARATO DECORATIVO E ALLE OPERE D'ARTE (scheda dettagliata a parte)**

**B<sub>28.1</sub> - Descrizione apparato decorativo o opera d'arte**

.....

.....

.....

.....

**B<sub>28.2</sub> - Descrizione danno**

.....

.....

.....

**B<sub>28.3</sub> - Provvedimenti provvisori sugli apparati decorativi e sgombero opere d'arte mobili**

SI CONSIGLIA INTERVENTO STORICO DELL'ARTE

.....

.....

.....

**STIMA DEL COSTO PER LA SALVAGUARDIA DELLE OPERE D'ARTE**                 €     \_ \_ \_ \_ \_ \_ ,00



**B<sub>29</sub> – DESCRIZIONE E STIMA SOMMARIA DELLE OPERE NECESSARIE****B<sub>29.1</sub>** - Descrizione opere di ripristino strutturale (nuovi danni e danni pregressi aggravati)

.....

.....

.....

STIMA DEL COSTO PER IL RIPRISTINO STRUTTURALE €    \_ \_ \_ \_ \_ \_ \_ \_ \_ \_ ,00

**B<sub>29.2</sub>** - Descrizione opere di finitura, impiantistica e miglioramento sismico

.....

.....

.....

STIMA DEL COSTO OPERE FINITURA, IMPIANTISTICA E MIGLIORAMENTO SISMICO €    \_ \_ \_ \_ \_ \_ \_ \_ \_ \_ ,00

**B<sub>29.3</sub>** - Descrizione opere di pronto intervento (eventualmente indicare anche il costo del P.I. "a finire")

.....

.....

.....

STIMA DEL COSTO OPERE DI PRONTO INTERVENTO €    \_ \_ \_ \_ \_ \_ \_ \_ \_ \_ ,00

**B<sub>30</sub> – NOTE**

.....

.....

.....

.....

.....

.....

.....

**B<sub>31</sub> – DOCUMENTAZIONE ALLEGATA** SI    NO

DESCRIZIONE

.....

.....

.....

**B<sub>32</sub> – SQUADRA CHE HA ESEGUITO IL RILIEVO**

SISMA	C.O.M.	SQUADRA N.	
<i>Componenti della squadra</i>			
Cognome e nome	Qualifica	Ente appartenenza	Firma

Modello B-DP PCM-DPC MiBAC 2006

## ABACO DEI MECCANISMI DI COLLASSO DEI PALAZZI

### M1. RIBALTAMENTO DELLE PARETI

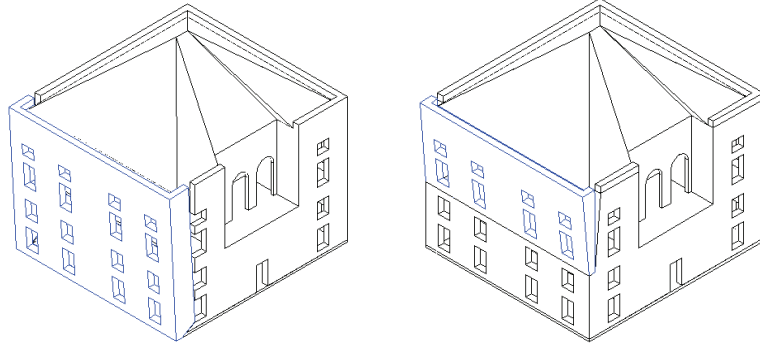

### M2. INSTABILITA' VERTICALE DELLE PARETI

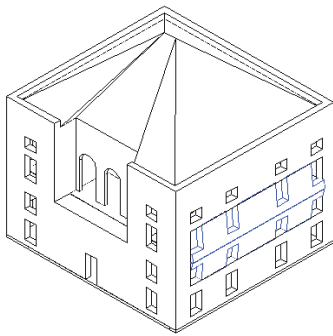

### M3. ROTTURA A FLESSIONE DELLE PARETI

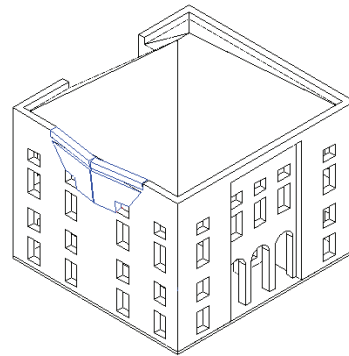

### M4. RIBALTAMENTO DEL CANTONALE

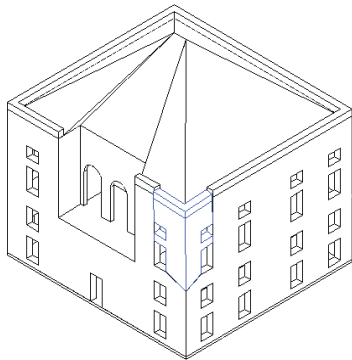

### M5. TAGLIO NELLE PARETI ESTERNE: MASCHI

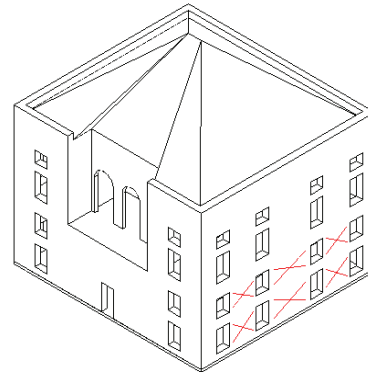

### M6. TAGLIO NELLE PARETI ESTERNE: FASCE

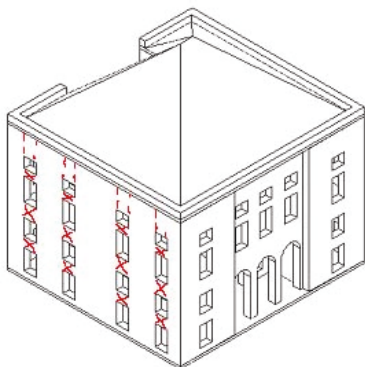

### M7. TAGLIO NELLE PARETI INTERNE

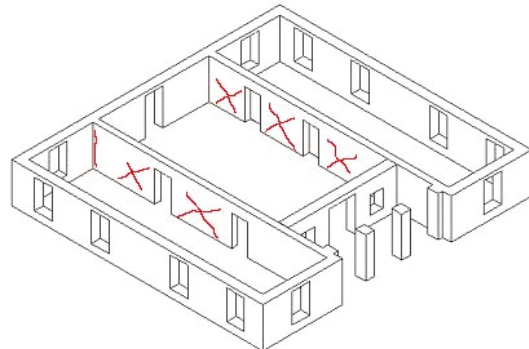

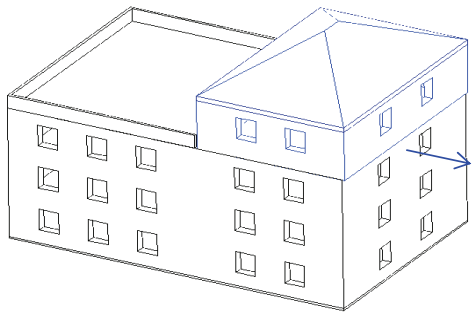
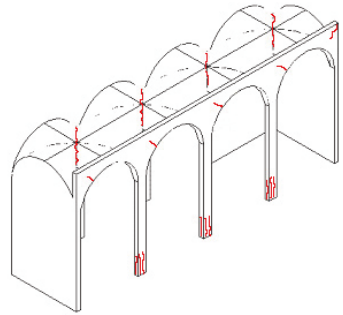
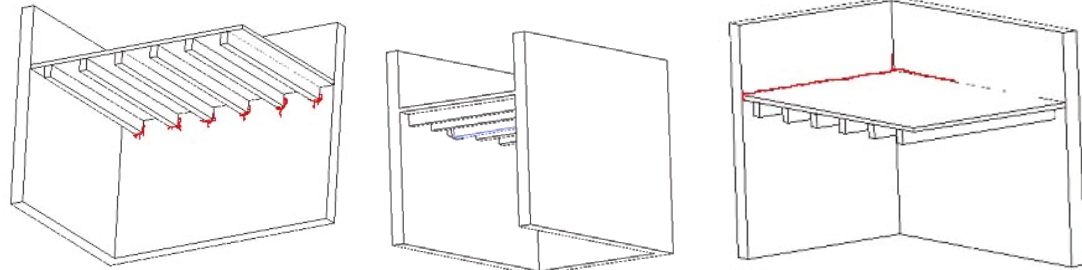
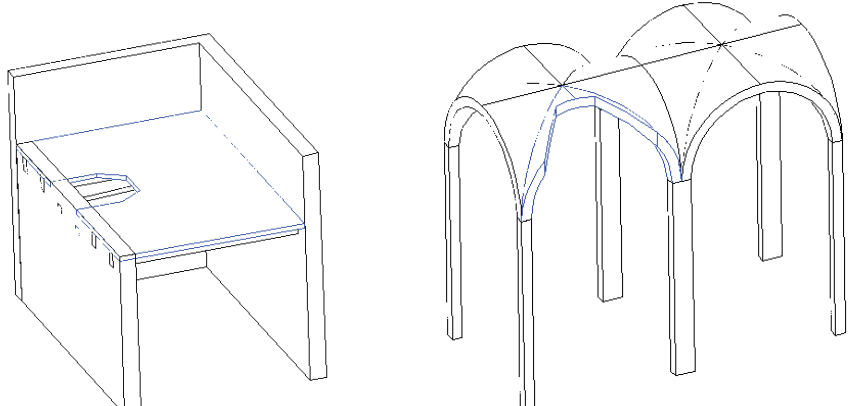
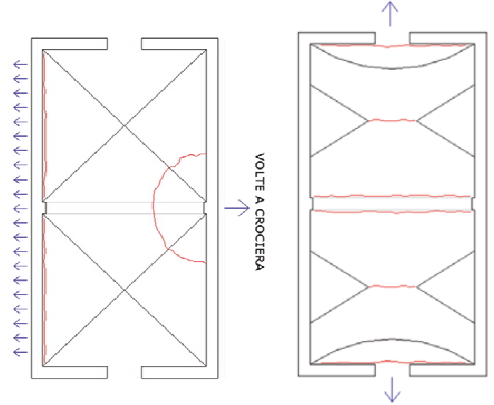
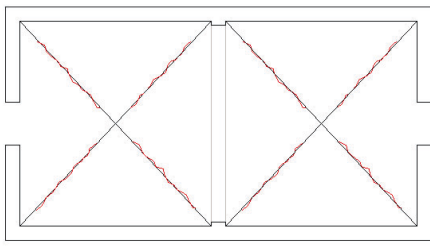
<p><b>M8. SCORRIMENTO DI PIANO</b></p> 	<p><b>M9. DANNO AI PORTICATI/ LOGGE</b></p> 
<p><b>M10. SFILAMENTO TESTA DELLE TRAVI E/O MARTELLAMENTO</b></p> 	
<p><b>M11. COLLASSI LOCALI DELL'IMPALCATO O DELLA VOLTA</b></p> 	
<p><b>M12. DANNO ALLE VOLTE PER ROTAZIONE DELLE IMPOSTE</b></p>  <p style="text-align: center;">VOLTE A CROCIERA</p> <p style="text-align: center;">VOLTE A BOTTE</p>	<p><b>M13. DANNO ALLE VOLTE PER DEFORMAZIONE DI PIANO</b></p> <p style="text-align: center;">VOLTE A PADIGLIONE</p> 

**M14. DANNO ALLE SCALE**

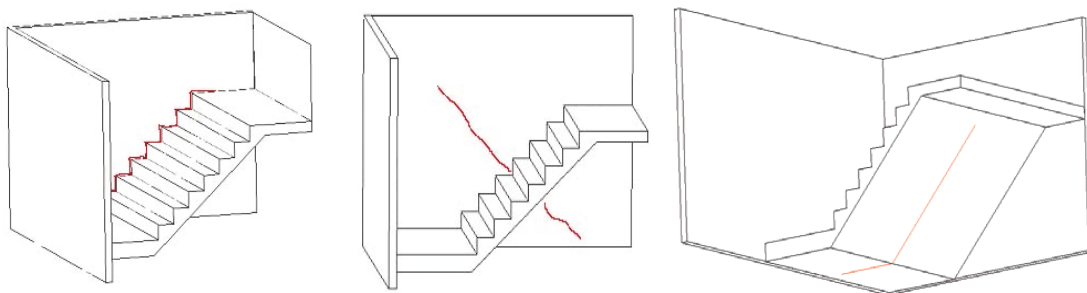

**M15. DANNO NEGLI ELEMENTI DI COPERTURA**

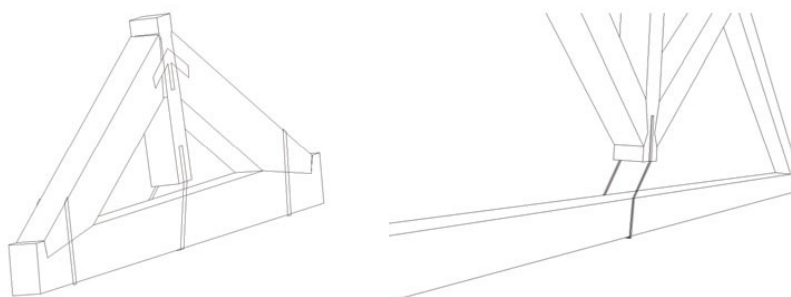

**M16. DANNO AL MANTO DI COPERTURA**

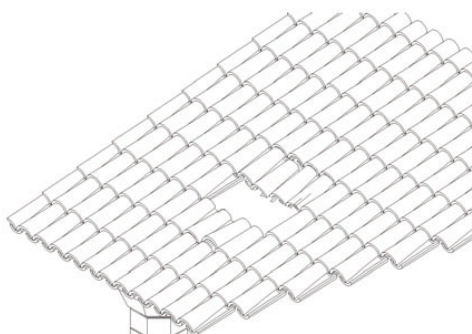

**M17. RIBALTAMENTO DELLE FASCE SOTTOTETTO E DEL TIMPANO**

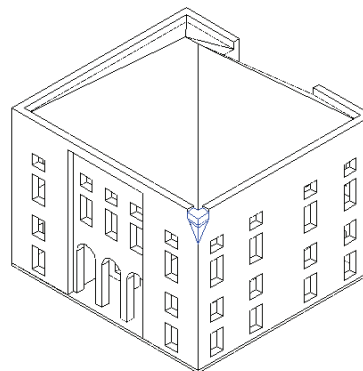

**M18. DANNO AGLI ELEMENTI AGGETTANTI/SVETTANTI**

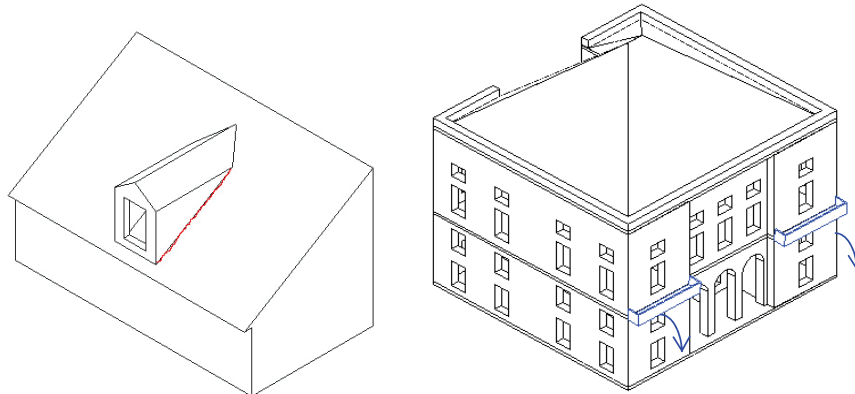

**M19. COLLASSI LOCALI PER IRREGOLARITA' COSTRUTTIVE E DEL MATERIALE**

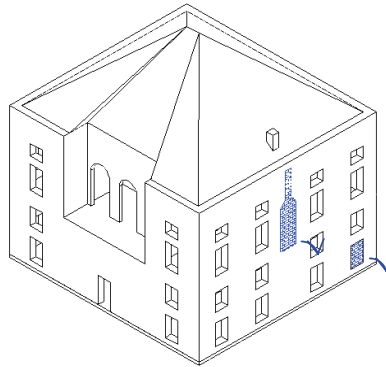

**M20. DANNO PER IRREGOLARITA' DI FORMA**

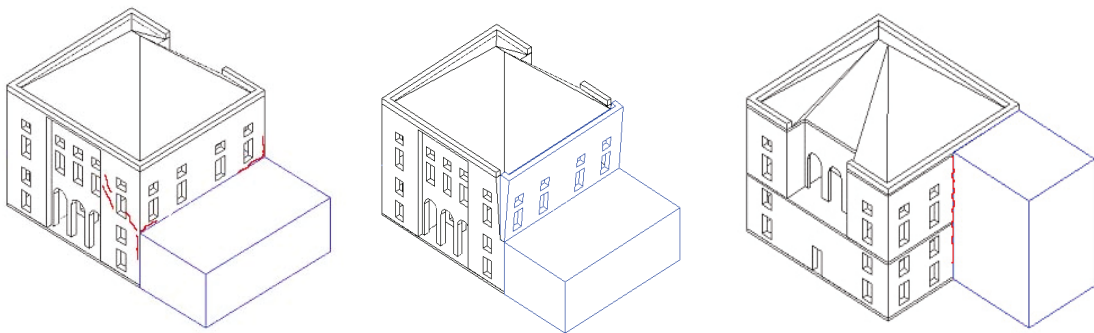

**M21. DANNO NEI CORPI ANNESSI**

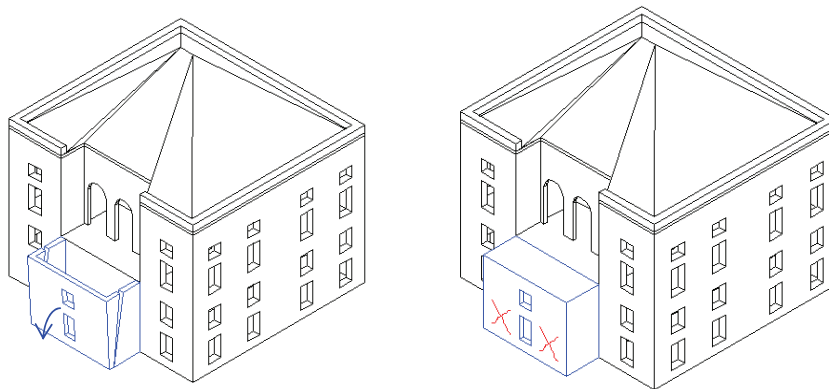

**M22. CEDIMENTO DI FONDAZIONI**

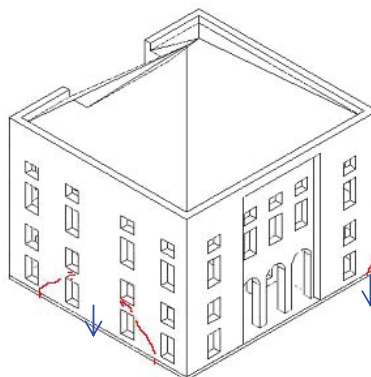

- **Emergency Condition Analysis Forms - first level**

The CLE (Commissione Tecnica per la microzonazione sismica, 2015) is a tool designed to verify the system elements of emergency management, identified from the Civil Protection Plans (emergency areas, strategic buildings and infrastructure networks). It thus tests the efficiency of the emergency structures even when the damage to the inhabited areas has led to the interruption of urban functions, including housing functions. It is a tool that wants to carry out a type of vulnerability assessment not of an architectural element, but of an entire system of emergency management, which should be actively maintained and functional in case of an earthquake. The tool marks an important step for research in the vulnerability field which begins to dialogue with urban planning tools. It was initially developed within the UrbiSIT project started in 2006 and was subsequently tested in the municipality of Faenza. To date, many municipalities in Italy have already tested their emergency systems (Fig. 24).

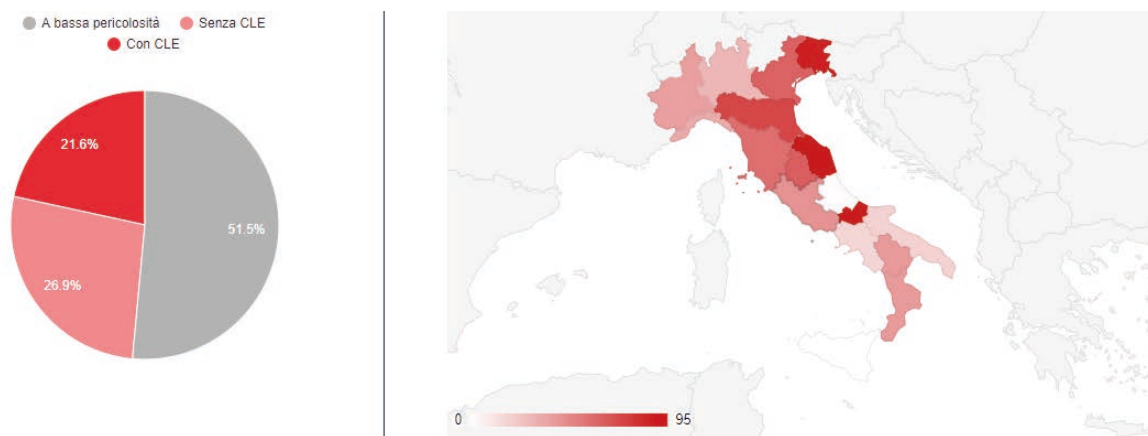

Fig.24. Map showing Emergency Limit Condition analysis studies performed. Source <https://www.webms.it/servizi/stats.php>

The analysis of the CLE of the urban settlement is carried out using the forms prepared by the Technical Commission referred to in Article 5 paragraphs 7 and 8 of OPCM 3907/2010 and released by specific decree of the Head of the DPC. At the base of this analysis there is therefore:

- a. the identification of buildings and areas that ensure the strategic functions for the emergency;
- b. the identification of the infrastructures of accessibility and connection with the environment, of the buildings and areas mentioned in point a. and possible critical elements;
- c. the identification of the structural blocks and of the single structural units that can interfere with the infrastructures.

The filling in of the related forms for the CLE analysis is therefore structured as an action aimed at the mitigation and reduction of seismic risk and must be carried out in connection with the necessary studies of seismic micro-zonation. For the settlement analysis it is therefore necessary to first identify the structures aimed at the emergency management through the Strategic Buildings (ES) and Emergency Areas (AE), and the system of interconnection between these structures and the accessibility system to the area through the Accessibility and Connection Infrastructure (AC). Once the main emergency system

elements have been pointed out, it is necessary to assess the interference of residential and non-residential buildings through the use of two forms: the interfering Structural Blocks form (AS) and the Structural Units form (USc). Their presence in the emergency system must be seen as a guide for the administrations in order to evaluate whether to define an alternative system for emergency management or to promote the seismic improvement of the interfering buildings.

- **Second-level forms**

Alongside the first-level tools previously explained, there are also second-level tools which are commonly used for a more detailed survey at the scale of historic buildings. We are referring here to the second-level form for masonry buildings developed by GNDT and the second-level form for church vulnerability analysis which is also included within the MIC guidelines (Ministero per i Beni e le Attività Culturali, 2006). Since they are based on a more in-depth building investigation, those tools are not designed to operate in the emergency phase. They should operate during ordinary building management, or even, after the emergency phase, only when the damaged buildings have already been designated secure.

The GNDT form is applied to masonry buildings, regardless of whether they are historic buildings or new constructions, and is essentially the oldest tool in existence for masonry buildings. Designed only for isolated buildings, it is based on an assignment score that is applied to a limited number of parameters (11) through increasing classes of vulnerability (Tab 1).

Parameters	Short description	Vulnerability Class				Weight		
		A	B	C	D			
P1	Organization of vertical structures	Age of the construction and connection typology between the walls		0	5	20	45	1
P2	Nature of vertical structures	Vertical element typology		0	5	25	45	0.25
P3	Qualitative resistance	Walls' shear strength assuming box behaviour		0	5	25	45	1.5
P4	Location of building and type of foundation	Topographical conditions of the ground and foundations characteristics and depth		0	5	25	45	0.75
P5	Floor typology	Quality of floor type considering stiffness and connection with the walls		0	5	15	45	1
P6	Plan regularity	Length/width ratio of the building plan		0	5	25	45	0.5
P7	Height regularity	Mass variation in elevation and the presence of arcades or towers		0	5	25	45	1
P8	Distribution of plan resisting elements	Spacing between walls		0	5	25	45	0.25
P9	Roof typology	Weight and characteristics (thrust) of the roof		0	15	25	45	1
P10	Non-structural elements	Presence, typology and connection to the building		0	0	25	45	0.25
P11	Physical conditions	Masonry quality and cracking scenario		0	5	25	45	1

Tab.1. Parameters considered in GNDT II level form

The normalized sum of these scores provides the vulnerability index of the structure. This has been, and still is, the baseline for further methods that attempt to overcome some of the model's limitations. For illustrative purposes, we can mention the Formisano method (Formisano et al., 2015), which suggests the inclusion of additional parameters in order to consider vulnerability factors related to the building's presence within an urban block.

The second-level form for churches is a straight derivation of the form proposed in 1997 by RU of Professor Lagomarsino. Revamped together with the first-level tool after the 2002 earthquake, it proposes an identification of both the damage level and the vulnerability index for the 28 probable collapse mechanisms. The index is also related to the relationship between the weight ( $\rho_{ki}$ ) attributed to the macro-element (Fig. 25) and the presence of a series of anti-seismic devices ( $v_{kp}$ ) or vulnerability factors ( $v_{ki}$ ).

MECCANISMO DI COLLASSO	Valore assegnato	Range di variabilità
1 - RIBALTAMENTO DELLA FACCIATA	1	
2 - MECCANISMI NELLA SOMMITÀ DELLA FACCIATA	1	
3 - MECCANISMI NEL PIANO DELLA FACCIATA	1	
4 - PROTIRO – NARTECE		0.5 ÷1
5 - RISPOSTA TRASVERSALE DELL'AULA	1	
6 - MECCANISMI DI TAGLIO NELLE PARETI LATERALI	1	
7 - RISPOSTA LONGITUDINALE DEL COLONNATO (chiese a più navate)	1	
8 - VOLTE DELLA NAVATA CENTRALE	1	
9 - VOLTE DELLE NAVATE LATERALI	1	
10 - RIBALTAMENTO DELLE PARETI DI ESTREMITÀ DEL TRASETTO		0.5 ÷1
11 - MECCANISMI DI TAGLIO NELLE PARETI DEL TRASETTO		0.5 ÷1
12 - VOLTE DEL TRASETTO		0.5 ÷1
13 - ARCHI TRIONFALI	1	
14 - CUPOLA - TAMBURO/TIBURIO	1	
15 - LANTERNA	0.5	
16 - RIBALTAMENTO DELL'ABSIDE	1	
17 - MECCANISMI DI TAGLIO NELL'ABSIDE	1	
18 - VOLTE DEL PRESBITERIO O DELL'ABSIDE		0.5 ÷1
19 - MECCANISMI NEGLI ELEMENTI DI COPERTURA - (pareti laterali aula)	1	
20 - MECCANISMI NEGLI ELEMENTI DI COPERTURA - (trasetto)		0.5 ÷1
21 - MECCANISMI NEGLI ELEMENTI DI COPERTURA - (abside, presbiterio)	1	
22 - RIBALTAMENTO DELLE CAPPELLE		0.5 ÷1
23 - MECCANISMI DI TAGLIO NELLE PARETI DELLE CAPPELLE		0.5 ÷1
24 - VOLTE DELLE CAPPELLE		0.5 ÷1
25 - INTERAZIONI IN PROSSIMITÀ DI IRREGOLARITÀ		0.5 ÷1
26 - AGGETTI (VELA, GUGLIE, PINNACOLI, STATUE)	0.8	
27 - TORRE CAMPANARIA	1	
28 - CELLA CAMPANARIA	1	

Fig.25. Weights to be associated with the different macro-elements for the vulnerability assessment

Quite unlike the GNDT form, the vulnerability index is not obtained through a normalized sum, but rather through a calculation that appears to be slightly more challenging yet is very similar in approach to that of the damage index in the first-level form:

$$i_v = \frac{1}{6} \frac{\sum_{k=1}^{28} \rho_{ki} (v_{ki} - v_{kp})}{\sum_{k=1}^{28} \rho_{ki}} + \frac{1}{2}$$

## 1.4 Timelines for First-Level forms

As far as the AeDES and Cultural heritage forms are concerned, the first-level forms currently working in Italy are tools which are used in the immediate post-event phase. Since they operate in the emergency phase, the requirements for these instruments are: first conciseness, in order to collect all the minimum required data; and then quickness, to ensure the safety of the surveyors, especially after the main-shock when aftershocks still occur. Although generally neglected, a further relevant requirement is the immediacy of use of the instrument. If we analyse the improvements that these tools have undergone over time (or have not undergone), we can clearly see how the purpose of damage survey activities followed the attainment of these objectives. Although it is impossible to quantify how much time is ideal to carry out a correct and exhaustive first-level survey, in very



general terms the first-level tools today try to spend around 1 hour, maximum 2 in the case of difficult buildings. Indeed, the evaluation is closely related to the state of the damage (the possibility to inspect in safety) and to the complexity of the building surveyed (the need to complete more than one form).

Considering the AeDES forms, nowadays you can easily understand how an inspection aimed at the judgment of practicability does not require more than an hour. Due to a continuous training campaign, in this time surveyors are able to inspect the building, fill in the form, and verify the structural units' subdivision. In the case of the L'Aquila earthquake (2009), the DPC employed about 150 teams/day which carried out about 1000 to 1800 surveys every day (Dolce et al., 2009), with an average of about 40 minutes per survey. In the case of the Emilia earthquake (2012) instead, the estimates reported refer to about 180 teams/day able to perform about 1000-1200 surveys (Dolce & Di Bucci, 2012), with an average of about 50 minutes per survey. In addition, in the AeDES form case, the data accuracy is ensured by the training of architects, geometers and engineers as well as by validation from the reconstruction offices which should confirm the correspondence between the building damage and the seismic event. Since it has been studied and progressively improved, the form is therefore a concise and straightforward tool and since it is also well-known to the surveyors, it is quick.

Analysing the data of the A-DC form, we can see that this tool has followed the same trend of AeDES forms. Initially with the 1997 earthquake, the RU, which drafted the first model, estimated that a survey with a second-level form could be achieved in about an hour's time (See section 1.2). Undoubtedly, the first tool developed was easily compilable in this timeframe when it was used by professionals already skilled in the collapse mechanism analysis and in the identification of the elements constituting seismic action load factors or anti-seismic devices. At the beginning, it was not considered that the Cultural heritage survey would be carried out by teams composed mainly of architects, archaeologists as well as art historians. Such teams in the first phase of emergency are supported by Fires Fighters and, if available, by structural engineers belonging to other public or research agencies such as Universities. The manual and the related abacus attached to the form certainly enable us to easily recognize the mechanisms activated by the earthquake even if we are professionals not necessarily skilled in the subject (moving towards the immediacy of use). However, the identification of anti-seismic devices or elements of weakness requires not only a very careful visit, not always feasible in the emergency phase<sup>25</sup>, but also a deep knowledge of the structures' behaviour in order to carry out the survey quickly. With the aim to provide the aforementioned features, at the end the adopted tool was simplified in a first-level form which ensures the quickness of the visit and in which the abacus, supporting identification of the activated collapse mechanisms and of the damage, allows for satisfying also the features of conciseness and immediacy, in this case strictly correlated<sup>26</sup>. To date, an average of one hour per church has been confirmed for this instrument as well. This

.....

25 An on-site visit that seeks to identify these data cannot avoid analysing every building element including, above all, roof structures. These structures are normally difficult to access, and undoubtedly dangerous or unsafe after an earthquake.

26 The collapse mechanism identification represents the result of the observed cracks and can be easily carried out even without an exhaustive knowledge of the historic structures. This is possible due to the abacus that allows an immediate understanding of the mechanisms.

datum has been demonstrated by the survey carried out in the 2009 earthquake where 6 to 10 teams/day have worked on the survey of cultural heritage, carrying out in one day the survey of about 6-8 churches per team, for an average of about 1 hour/church. In Emilia earthquake case, even though the detailed data regarding the amount of time needed to churches survey are not declared, the ease of filling in the form “within defined times”(Di Francesco, 2014:37) is confirmed, thus consolidating the respect of the characteristics of quickness, conciseness and immediacy of use of the instrument.

Quite different is the situation of the B-DP form instead. As already remarked in the previous chapter, the form has not undergone any improvement following the effective use in the emergency phase. It was developed between 2002 and 2006, the year in which it was officially adopted. It was also tested in minor seismic events. Therefore, in 2006 the legislator believed to adopt a tool already widely tested. Practically, this has represented the very limit of the tool, which to date has been the object of ongoing simplification requests from the real form users. Belonging the surveyor to professional profiles far from the engineering, similarly to what already happened for the second-level churches model, the immediacy of the use in emergency phase has been overestimated. In fact, the estimates of the survey times using the B-DP form both in the L’Aquila and Emilia earthquakes seem to confirm this idea.

In the above-mentioned reports for the L’Aquila Earthquake, the survey teams for cultural heritage were composed of an official, a firefighter and an expert structural engineer. Belonging to ICR or other institutions such as engineering departments of universities, the structural engineer was generally already involved in the vulnerability analysis activities. He was an expert indeed. In this condition, alongside the 6-8 team forms/day for churches, about 2 buildings/day were surveyed. Already by comparing the data for the churches and those for the buildings in the 2009 earthquake, where the survey was supported by the same technicians who had studied or experimented the Stately Buildings form, it is clear that, with an average of 3-4 hours/stately building, the form could be considered an effective tool from the result point of view, but not quick. Already after the L’Aquila earthquake, the researchers of the several RUs claimed the need to implement changes regarding the effective use of the forms.

If we then observe the results of the surveys carried out with this form in the Emilia earthquake, the situation worsens considerably. As previously stated, the survey teams in this earthquake could also count on the support of a structural engineer who, in this case, came from the University. However, this assistance was already lacking three months after the seismic event and the structural engineers were recruited as volunteers or by assignment. Unlike in the previous earthquake, the technicians did not include the same engineers who had previously dealt with the survey operations in the L’Aquila earthquake and who had already widely experienced the instrument. In the case of the Emilia earthquake, the 6-month post-earthquake report refers to the survey of at least 1 building/day, but with a real average of 1 building every 2 days(Di Francesco, 2014). Among the complaints raised by the tool use are the tool length and the lack of a specific manual to refer to in order to understand its filling in. Regarding the first, to the detriment of the conciseness criterion, the surveyors are requested both to carry out a recognition of structural behaviour, and a detailed survey of damage for every single building’s element. This nullifies the nature of a concise instrument. Regarding the second claim, first of all the problem arises from the similarity between the B-DP form and the A-DC form, which suggests that a manual was not necessary since the

B-DP form could hypothetically be compiled as the A-DC form. Moreover, a handbook for the form was not really necessary when the same structural engineers who had tested it were assisting the surveys. For these reasons it had never been drafted. It is clear that with an average of more than one day per building and a general uncertainty on the filling in procedure, in the Emilia more than in L'Aquila earthquake, the B-DP tool has demonstrated all its inadequacy in terms of quickness, conciseness and immediacy of use.

FORM/FEATURES	FORM FEATURES		
FORM TYPE	CONCISNESS	CELERITY	USAGE IMMEDIACY
AeDES	X	X	X
FORM A-DC	X	X	X
FORM B-DP	/	/	/

Tab.2. Ratio of the Level I sheets to the main criteria outlined

## 1.5 First-level forms and vulnerability

The difference between the first and second-level forms concerns the type of data collected and not the type of analysis they can undergo (see section 1.2). While the first-level forms collect the minimum data necessary to estimate damages and repair costs, the second-level forms allow the acquisition of more exhaustive data. Since for both models it is possible to carry out analysis with the same methodology, their application thus differs in the expected result in terms of accuracy and main reference scale of application.

More accurate data, which can take into account factors that can amplify or decrease vulnerability, allows for more accurate analyses but with a greater consumption of time. It is therefore clear that, even before selecting the appropriate methodology for a vulnerability analysis, it is necessary to be aware of the instruments available, the scale of investigation and the validity framework of the results (Fig.26).

expenditure	increasing computation effort →				
	building stock		individual building		
application					
methods	observed vulnerability	expert opinions	simple analytical models	score assignment	detailed analysis procedures

Fig.26. Graphic scheme about the application of vulnerability assessment to existing buildings at different scale according to the computational effort. The image relates also the application scale to different methodologies (Lang, 2002).

Due to the nature of quick tools (i. e. able to acquire a wide range of simplified information in little time), the first-level forms are designed as tools mainly for territorial analysis, while the second-level forms, providing more precise data, are more suitable at the urban/building scale. However, assuming certain approximations, it is still possible to apply the second-level form's methodologies generally to first-level forms, thus obtaining a simplified meso-scale vulnerability. These types of analysis are able to support the decision-making processes.

Below are some examples of the first-level forms used for vulnerability analysis between the territorial and the meso-scale.

- Molise 2002 Earthquake: from Aedes data to the vulnerability index according to the GNDT second-level methodology** (Cifani et al., 2007). After the Molise earthquake (2002) several researchers, using data from post-earthquake surveys, seismic hazard models, seismic microzonation and from the delivered Simplified Preliminary Designs, tried to evaluate the cost increment of a seismic retrofit according to the different seismic territorial hazard studies and in relation to the different seismic regulations. In order to identify the relationship between the intervention cost and the ground acceleration, the researchers decided to use the vulnerability analysis method related to the vulnerability second-level form for masonry buildings provided by GNDT. The data to identify the different classes for every vulnerability parameter of the methodology have been deduced from the several Aedes sections through appropriate simplifications (Tab. 3).

This survey has been carried out for a total of 14000 buildings in the whole Campobasso province, an analysis therefore at the territorial scale. This survey has been carried out for a total of 14000 buildings in the whole Campobasso province, an analysis therefore at territorial scale.

Parameters		Vulnerability Class				Aedes Section where find data for class attribution
		A	B	C	D	
P1	Organization of vertical structures	0	5	20	45	3
P2	Nature of vertical structures	0	5	25	45	3
P3	Qualitative resistance	0	5	25	45	2;3
P4	Location of building and type of foundation	0	5	25	45	7
P5	Floor typology	0	5	15	45	3
P6	Plan regularity	0	5	25	45	3
P7	Height regularity	0	5	25	45	3
P8	Distribution of plan resisting elements	0	5	25	45	/
P9	Roof typology	0	15	25	45	3
P10	Non-structural elements	0	0	25	45	5
P11	Physical conditions	0	5	25	45	2

Tab.3. Parameters used in the GDNT method and Aedes Section used by researcher to identify score for every parameter (Cifani et al., 2007)

- Emilia 2012 Earthquake: Vulnerability at the building and urban scale of the Ferrara historical center through the Aedes and AS (CLE) forms** (Dolce & Di Bucci, 2012 and Dolce et al., 2015). After the seismic shocks of 20 and 29 May 2012, the Major Risks Commission sent a report about the potential development of the seismic swarm to the head of the DPC. The analysis suggested the possible activation of a fault between Finale Emilia and Ferrara with high intensity quakes. Consequently, a series of mitigation measures were implemented, including a vulnerability analysis of the Ferrara historic center, the city with the most inhabitants on the fault. Such analysis was carried out through the use of two first-level tools already effective for the earthquake, the AeDES form for the assessment of post-earthquake practicability and the AS (Structural Urban Block) form, one of the five first-level forms for the CLE analysis. Except for the buildings for which a seismic inspection had been required after the 2012 earthquake, the AeDES form was compiled only up to section 3, i.e. up to the section describing the building construction features. The survey carried out by volunteer technicians, equipped with iPads for direct digital data acquisition, focused only on the outside buildings, preferring

to use data from the Ferrara Department of Architecture to identify the inner construction features which were considered homogeneous within specific areas. The AS-form-survey was then added. The form, specifically designed for city blocks, provided both the framework for classifying the single building units surveyed with the AeDES forms as well as a vulnerability assessment of urban blocks. The combined use of these instruments allows for a vulnerability assessment both of each individual building and urban block by taking into account the mutual exchange that buildings could have.

- **Macroseismic approach to vulnerability: behaviour modifiers in the RISK-UE form compared to first-level survey for cultural assets data** (Mouroux & Le Brun, 2006). In a broader scenario, the Risk-EU project has played a great role in vulnerability assessment. In particular, two different approaches have been presented for the estimation of damage: macro-seismic and mechanical. Among the research partners was the University of Genoa with Prof. Lagomarsino, whose work was carried out inside the WP04 and WP05 in relation to the vulnerability assessment with first-level (macro-seismic) or second-level (mechanical) approaches (Lagomarsino & Podestà, 2005). In detail, the macro-seismic approach relates the potential mean damage in accordance with the macro-seismic intensity (I), the building type vulnerability (V) and a ductility factor (Q), which is also defined by the object type investigated, as follows:

$$\mu d = 2.5 \left[ \frac{I + 6.5V - 13.1}{Q} \right]$$

Since the vulnerability used is not the vulnerability of the building itself, but the mean vulnerability obtained for similar structures, such a formula identifies a typological mean damage, i.e. depending on the building's class (churches, stately buildings, theatres...). This is a so-called Level 0 approach, because it provides expected damage assumptions by type, and may only be used for land-scale assessments among the investigated classes. In order to take into account the specificities of each building, then the parameter V has been defined as the sum of a vulnerability of typological nature (V<sub>0</sub>) and some behavioural modifiers describing any structural system weaknesses, the site features, or other vulnerability parameters.

$$V = V_0 + \sum V_k$$

These modifiers, both of a general and specific nature, were then added to a survey form to obtain the minimum data to assess a vulnerability index with the macroseismic approach through a quick survey, i.e. first-level. If you carefully examine the first sections of the first-level tools designed for cultural heritage (A-DC and B-DP forms) you can observe how much the above-mentioned behavioural modifiers are integrated therein. For example, regarding the general parameters, the site morphology of the RISK-EU form corresponds to subsections A7 and B7 of the two models, the maintenance status corresponds to subsections A15 and B15, while the masonry quality can be inferred through section B19 for the B-DP form. Similarly, specific behavioural modifiers can be found: sections A8 and B8 refer to the position within an urban block, the plan and height regularity is taken from section B17 for the B-DP form or from sections A16 and A24 in the A-DC (Fig. 27), so on and so forth.

By applying an approach such as behaviour modifiers, it is therefore feasible to use the first-level forms for Cultural heritage to perform a more accurate vulnerability assessment on an urban scale.

<b>Stato di manutenzione</b>	scadente	+0.04
	medio	0
	buono	-0.04
<b>Livello di danno</b>	grave	+0.04
	leggero	+0.02
	nessuno	0
<b>Trasformazioni architettoniche</b>	si	+0.02
	no	0
<b>Interventi recenti</b>	si	+0.02
	no	-0.02

<b>Muratura di buona qualità</b>	si	+0.05
	no	0
<b>Morfologia del sito</b>	cresta	+0.04
	pendio	+0.02
	piano	0
<b>Regolarità in pianta</b>	<i>Dipende dalla tipologia</i>	
<b>Regolarità in altezza</b>	<i>Dipende dalla tipologia</i>	
<b>Posizione</b>	<i>Dipende dalla tipologia</i>	

<b>A<sub>15</sub> - STATO DI MANUTENZIONE GENERALE</b>						
Buono <input type="radio"/>	Discreto <input type="radio"/>	Scadente <input type="radio"/>	Pessimo <input type="radio"/>	In corso lavori <input type="checkbox"/>		
Eventuali precedenti lesioni esistenti		NO <input type="radio"/>	SI <input type="radio"/>	Limitate <input type="radio"/>	Estese <input type="radio"/>	Gravi <input type="radio"/>

<b>A<sub>7</sub> - CARATTERISTICHE DEL SITO</b>					
In piano <input type="radio"/>	Su rilievo / su cresta / su vetta <input type="radio"/>	Su riporto <input type="radio"/>	In pendio / su versante <input type="radio"/>	Avvallamento <input type="radio"/>	

Fig.27. Comparison among the data of RISK-UE Survey Form (Lagomarsino & Podestà, 2005) and the data of A-DC form.

# ***CHAPTER 2***

## ***The “Emila 2012” earthquake***



On the previous page the Modenesi tower, symbol of the 2012 earthquake. Source: <https://www.lapam.eu/notizie/normative/sisma-regione-emilia-romagna-proroga-le-scadenze-di-fine-lavori-e-rendicontazione/>



## 2.1 The “Emilia” earthquake

At 4.03 a.m. local time, on May 20, 2012 an earthquake hit the Emilia territory. The mainshock epicentre was about 30 km west of Ferrara, close to Finale Emilia. The local magnitude (ML) was 5.9 and the moment magnitude (MW) was between 5.9 and 6.1. The second strong quake occurred on May 29. The epicentre was between Medolla and Cavezzo, near Mirandola, with a local magnitude of 5.8 and the moment magnitude between 5.7 and 6.0. The aftershocks were numerous and in about fifteen days, 14 quakes with a magnitude of over 4.5 were recorded. The highest horizontal peak acceleration recorded by the National Accelerometric Network of the Civil Protection Department (RAN-DPC) in the epicentral area at the Mirandola and San Felice sul Panaro sites was about 300 cm/s<sup>2</sup>, while a maximum value of 900 cm/s<sup>2</sup> was recorded on the vertical axis at the Mirandola site. A feature of this earthquake, then observed in the numerous damages occurred, is a seismic action with a strong vertical factor.

Compared to a preliminary damage scenario formulated by the DPC - which estimated a VIII-IX-degrees epicentral macroseismic intensity after the mainshock - the real assessment fortunately reached only VII-VIII degrees (Fig. 1), even after the second earthquake which considerably worsened the situation (Dolce & Di Bucci, 2012). The final appraisal is however quite negative: 28 victims, 310 injured, 45,000 displaced people (Mariani, 2015:197), and about 13 billion euros of damage.

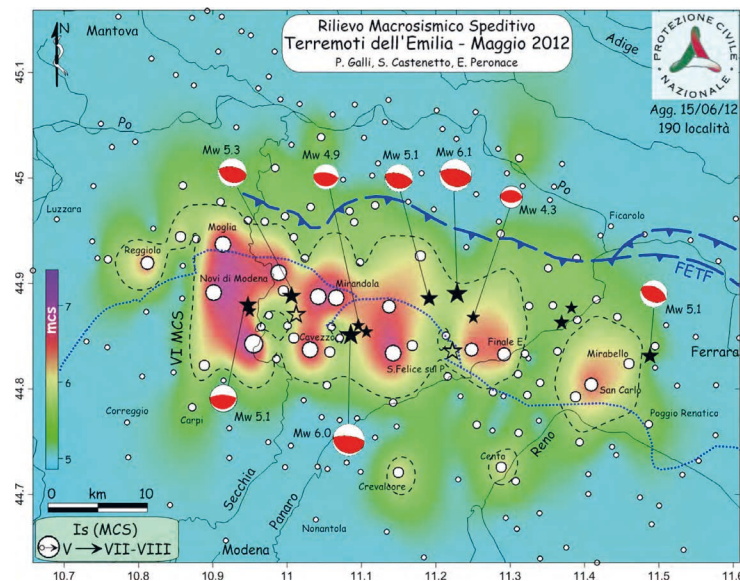

Fig.1. Distribution of intensity points detected by DPC on June 15, 2012. The chromatic background indicates qualitatively the areal shaking in terms of MCS. The dashed lines represent the interpolated isosequences of the VI degree of the MSC scale (Galliet al., 2012).

After 29 May, about 60 municipalities in the provinces of Ferrara, Modena, Bologna and Reggio Emilia were damaged by the earthquake, including the four chief towns. In addition to significant damage to monumental buildings, the earthquake also had a significant impact on manufacturing and agricultural areas. Indeed, In the Emilia crater area, where about 2% of the Italian GDP is produced, prefabricated factories and masonry rural buildings, together with cultural heritage, are the most damaged buildings.

The most relevant damages can be observed in the areas of the two epicentres. Among the most affected centres, Mirandola, Concordia sulla Secchia and Finale Emilia should be mentioned, while in the province of Ferrara the main damages are in municipalities such as Bondeno or Sant’Agostino, as well as Crevalcore and Reggiolo in the area of Bologna. The earthquake also produced in some areas soil liquefaction effects which greatly worsened the damage situation, mainly in regards to cultural heritage. However, it should be pointed out that, by comparing macroseismic intensities with the places with soil liquefaction effects, it was found that such effects were not related to higher macroseismic intensities but to the presence of paleochannels (Fig. 2).

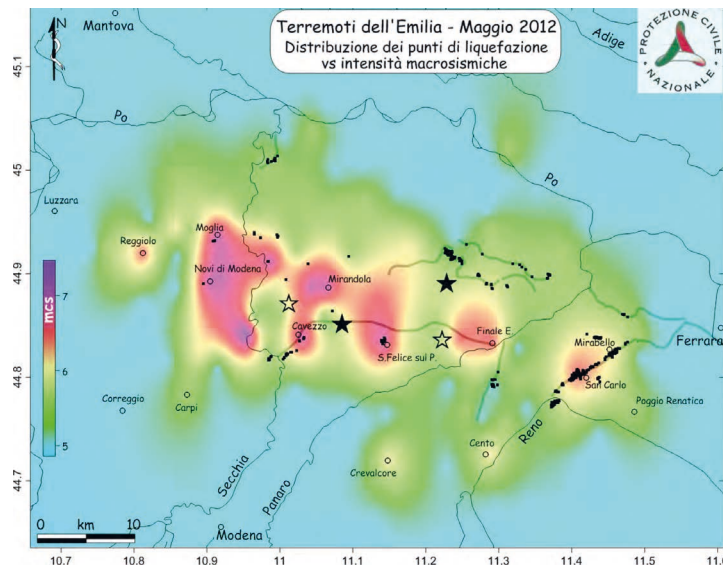

Fig.2. Distribution of liquefaction phenomena (black square) observed following the 2012 mainshocks in comparison to macroseismic intensity distribution (black and hollow stars, instrumental and macroseismic epicenters respectively)(Galli et al., 2012).

## 2.2 From emergency management to reconstruction management

- **The first emergency and the DPC activities**

On May 20, when the seismic crisis that struck the central part of the Po Valley occurred, the regulatory framework for emergencies had just been modified<sup>1</sup>, such as “a great earthquake in the task and operational procedures guidelines” (Dolce & Di Bucci, 2012). Among the most important changes that affected the Civil Protection activities in Emilia, the most notable are:

- The establishment of a 60-day deadline (which may be extended by a further 40 days) for the validity of the state of emergency<sup>2</sup> declaration.
- The direct authority of the DPC Chief to issue ordinances.

.....

1 DL 59/2012 concerning provisions for the reorganization of the National Service of Civil Protection and the strengthening of its operational capacity

2 The state of emergency corresponds to a timeframe within which an extraordinary regulation of measures and authority is applied to a territory in order to deal with exceptional events. Its declaration establishes the temporal and territorial limits for the application of this particular derogatory.

- The fixing of a threshold in the number of available resources for the issuing of emergency management ordinances.
- The immediate effectiveness of ordinances issued within the first 20 days of the state of emergency declaration by forwarding them to the Ministry of the Economy and Finance for approval. After the twentieth day, ordinances will only be issued in agreement with the aforementioned Ministry with regard to the competent aspects.

This is the new regulatory framework to which the DPC had to adapt quickly in order to provide an immediate response soon after May 20. In spite of this, it took less than an hour from the event to carry out an analysis of the possible damage scenario and experts were already travelling to confirm the actual damage and thus guide the population assistance operations as effectively as possible. One hour after the event the Operational Committee was already working and it remained in charge until 23 May.

On May 22, the Council of Ministers declared the state of emergency which, at first, involved only the provinces of Modena, Bologna, Ferrara and Mantova and, at the same time, issued the first ordinance with which the DPC Chief formally started the intervention activities of the National Service, appointing the Regional Director of Civil Protection as the person in charge of assistance. On May 30, following the next seismic event, a new state of emergency was issued that also involved the provinces of Reggio Emilia and Rovigo. On June 2, with ordinance number 3, the Direction of Command and Control-National Coordination Center of the Civil Protection Components and Operational Structures (Di.Coma.C) was established at the headquarters of the Civil Protection Regional Agency of Emilia-Romagna in Bologna, since it was considered the best site to better coordinate activities of the crater area. Therefore, soon after its establishment, it immediately started to build a relationship with all the other centres in the nearby territory: Aid Coordination Centers (CCS) at the provincial level, Municipal Operational Centers (COC) at the municipal level and Mixed Operational Centers (COM) for the provincial and inter-municipal coordination of activities.

During DPC’s 60-day leadership, the following tasks were performed and coordinated:

- Assistance was provided to people, including services such as setting up tents for the people displaced, arranging hotel accommodation and lodging in tents in the nearby farms in order to maintain production activities.
- The establishment of a “Working Group for the evaluation of liquefaction effects after the earthquakes of 20 and 29 May 2012 (Emilia-Romagna Region, PG.2012.0134978 of 31/5/2012)”. It is an interdisciplinary group mainly composed of geologists, geotechnical and structural engineers, from DPC, Emilia-Romagna Region, Province of Ferrara, geotechnical sections of the Civil Engineering Departments of the University of Ferrara and Florence, and professional orders of geologists and engineers. Its aims are the investigation and description of the soil liquefaction phenomena that occurred during the earthquake.
- The coordination of damage survey and practicability assessment through the AeDES forms, subsequently validated by the Geological, Seismic and Soil Service (SGSS) of the Emilia-Romagna Region, coordinated with Di.Coma.C.<sup>3</sup> itself.

.....  
3 <https://ambiente.regione.emilia-romagna.it/it/geologia/sismica/speciale-terremoto>

Regarding the damage survey activity, the technicians and volunteers’ efforts in the very first weeks after the earthquake were quite intense with around 180 teams/day and a peak of over 200 teams one month after the shaking (Fig. 3).

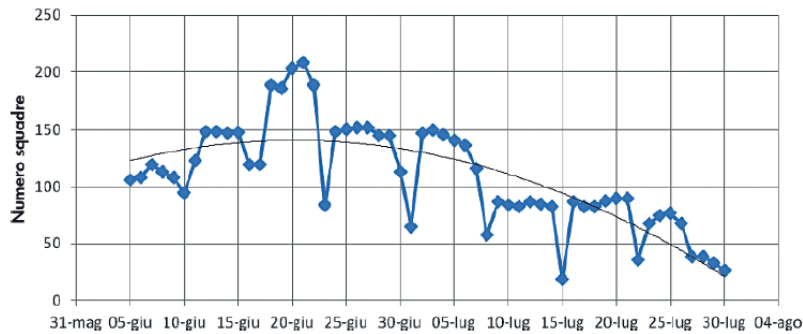

Fig.3. Trend of the daily number of teams employed in damage and practicability surveys during the 60 days of emergency administration by DPC (Dolce & Di Bucci, 2012).

In contrast to what happened in the 2009 Abruzzo earthquake, here no surveys were carried out to analyze all the buildings where the seismic macroseismic intensity was higher than VI. Truth be told, the practicability analysis was conducted but only when specifically requested by owners or tenants and after a previous visit for a quick assessment of buildings’ safety, avoiding a more in-depth inspection with AeDES form. By the expiration of the DPC action deadline, about 65000 visits had been carried out, out of which 40,000 surveys were conducted through the AeDES forms. By analysing the data, in the first 60 days of the emergency state about 89% of all the buildings surveyed with AeDES forms (40,000 out of a total of 4,450) were judged safe. All these data were then digitized through the SET application. Starting from July 2, these data were then transmitted to the Region and the municipalities with a periodic transfer planning, thus also allowing for monitoring by the municipalities themselves, which were requested to identify and notify any irregularities or discrepancies compared to their data.

Finally, an additional activity developed by the DPC in partnership with the Region’s Cartography section was the data forms geo-referencing on thematic maps about the practicability outcome (Mariani,2016: 65-66). This effort is part of a wider project of the emergency and reconstruction process: the communication of the reconstruction through the continuous updating and implementation of GIS cartography<sup>4</sup> (Fig. 4).

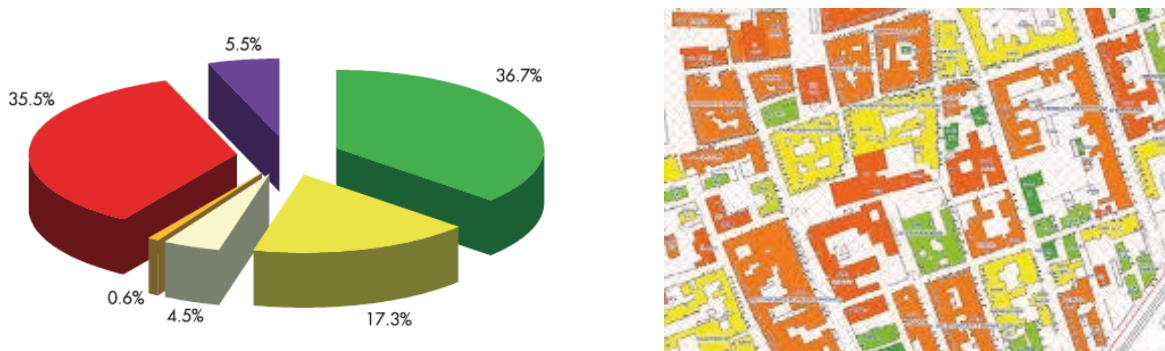

Fig.4. On the left the outcome in percentages of the practicability forms completed for the Emilia-Romagna earthquake (Dolce, Di Bucci, 2012). On the right example of cartography showing the practicability outcomes for the Mirandola municipality (Agenzia sanitaria e sociale regionale dell’Emilia-Romagna, 2016).

.....  
 4 The Ministry of Culture will provide its own cartography updating about cultural heritage.

On July 29, the 60 days available to the DPC came to an end and on August 2, the formal dismissal of the Di.Coma.C. took place with the formal power devolution to the Deputy Regional Commissioners, who had the task of completing the activities of population assistance and damage survey and then proceeding to the reconstruction phase.

The DPC, as usual, capitalized on its experience in Emilia-Romagna. Through the testing phase three main points can be highlighted, related to the emergency organization & management and to the damage survey. Firstly, regarding the organization and the management, the Emilian experience led to revisions on the DL 59/2012 that was converted into law 100/2012 and changed the emergency duration from 60+40 days to 90+60. It also granted permission to the Regional Governor to directly request the state of emergency. Regarding the damage survey, two experimentations took place during this emergency. The first one concerned the assessment of the vulnerability of the historic Ferrara centre (See section 1.5) and due to that, the CARTIS form has subsequently been created. The second experimentation concerned the testing phase carried out on a new model of AeDES form specifically drafted for industrial sheds. Indeed, the form was already under investigation and after the Emilian earthquake a pilot test was carried out on a few buildings. The GL-AeDES form has been officially introduced in our legislation with the DPCM 14/2015 (Presidenza del Consiglio dei Ministri, 2015).

- ***The Deputy Commissioner activity and the reconstruction process***

*“The streamlining of the decision-making processes, the key stakeholders involvement, and the increase of participatory engagement constitute the three main evaluation parameters to assess the resilience improvement which some innovative transformations in local governance have contributed to confer to the regional system [...]”* (Zuppiroli, 2020). These are the factors identified by arch. Zuppiroli as the main elements of the reconstruction process management of cultural heritage, but, in the emilian case, this definition is equally suitable for the whole process.

On June 6, the Government extended the emergency state until May 31, 2013 (D.L. 74/2012 (hen L 122/2012) and appointed the Emilia-Romagna, Lombardy and Veneto Governors as *Deputy Commissioners for population assistance, reconstruction and economic recovery* in their territories. Hence, it was up to them that the transfer of the emergency management had to be at the Di.Coma.C closure. On June 8, the Deputy Commissioner of Emilia-Romagna with the ordinance 1 established the *Institutional Committee of direction and monitoring* chaired by the Commissioner himself, by the representatives of the provinces and the mayors of the municipalities affected. he also immediately provided itself with its own Technical Structure.

It represented the first Commissioner act and it defined the key features of Emilia-Romagna governance. Indeed, it established a system based on the decisions-agreement with the local authorities. The assumption is that the agreement represents a model of efficiency, transparency and monitoring and that such a system thus conceived can safeguard the territory’s identity (Regione Emilia-Romagna, 2012). As a result, the *Institutional Committee* held weekly meetings, and the Commissioner often used the *Regional Table for Smart, Sustainable, and Innovative Growth* as a support. Reconstruction priorities were established and aimed at recovering activities as soon as possible. Emilia-Romagna then followed these steps in the reconstruction process.

1. **Reconstruction of schools and town halls.** The aim was to let students return to school in the month of September and at the same time, reactivate public services in the municipalities whose town hall was damaged. The two programs were planned to restore buildings with little damage and to set up temporary buildings where the existing ones had been excessively damaged.
2. **Reconstruction of factories.** Another point of crucial relevance was the recovery of productive activities. The crater area provided for 2% of the national GDP and, therefore, all possible efforts have been made to avoid a long-term production shutdown. Up to date about 81% of the approved projects have been accomplished (Fig. 5).

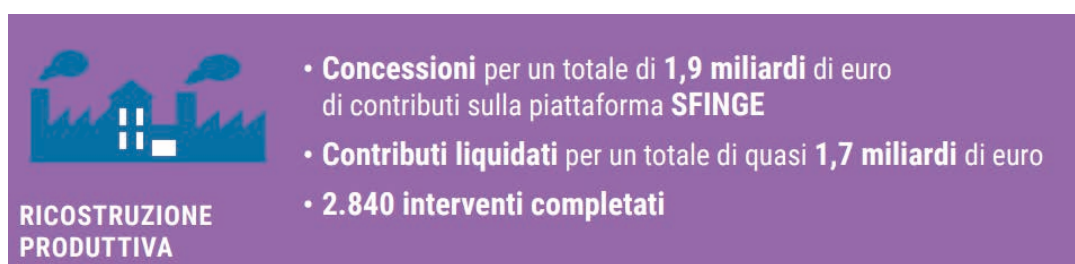

Fig.5. State of productive reconstruction reporting in sequence: billions approved in the concessions, billions paid and the number of completed interventions.

3. **Housing reconstruction.** Alongside the companies’ problems, housing was the other issue addressed. Criteria for the fund’s allocation have been immediately established and the reconstruction and re-entry into their homes has been carried out. The state of house reconstruction shows the approval of 8000 projects and the payment of a significant part of the allocated funds (Fig. 6).

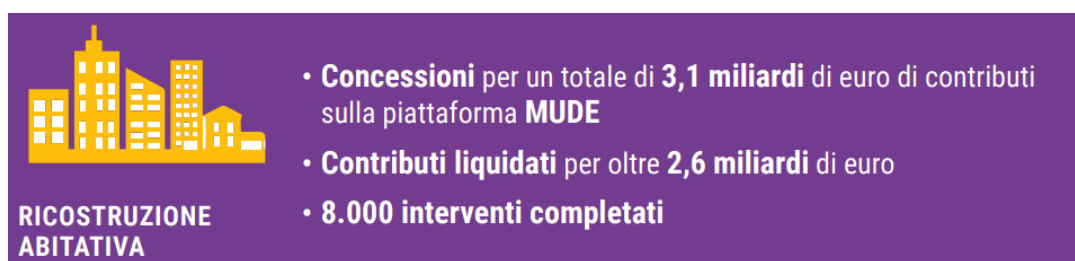

Fig.6. State of house reconstruction reporting in sequence: billions approved in the concessions, billions paid and the number of completed interventions.

4. **Reconstruction of Public Buildings.** Due to its procedural difficulties and the building typology involved, the last intervention made concerned the Reconstruction of Public Buildings. At the beginning of 2013, the recognition phase of the damage also for the cultural heritage reached a conclusion, a rather difficult and articulated operation managed by the Crisis Unit - Regional Coordination Mibac (hereinafter UCCR). In June 2013 the “Program for the repair and restoration of public buildings and cultural heritage” (hereinafter OOPP and BBCC Program)<sup>5</sup> containing the regulations and the financial funding for public reconstruction intervention was officially drafted and published. It is achieved through annual execution plans that address the program’s activities in thematic areas: the public assets plan, the cultural

.....  
 5 DGR n. 801 of June 17, 2013 and subsequently decree n. 513 of June 24, 2013

assets plan and the school and university plan. As the last point of the reconstruction priorities, today it is about halfway through its execution (Fig. 7)<sup>6</sup>.

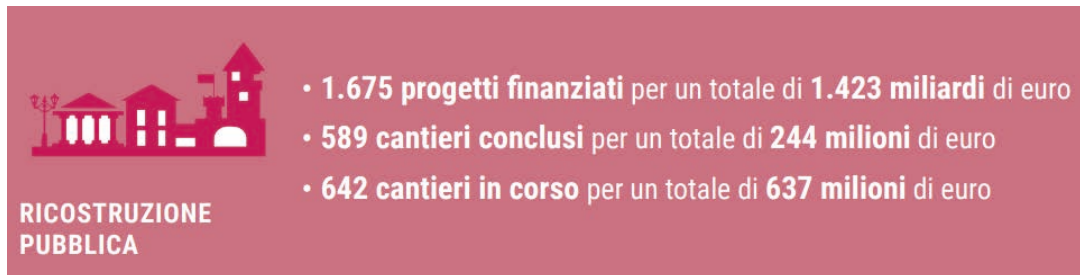

Fig.7. State of public reconstruction reporting in sequence: billions approved in the concessions, billions paid and the number of completed interventions.

In order to optimize the reconstruction process, each approval procedure has been entrusted to the most competent Authority in the matter of the project and, to support the processes, dedicated portals have been activated for the project’s submission and grant requests (MUDE for housing, SFINGE for companies and FENICE for public buildings). Therefore, the management of the housing reconstruction has been delegated to the Municipalities, the management of the companies’ reconstruction has been delegated to the Region and, in the case of cultural heritage, a further effort has been made to achieve a more efficient management of the long-term process than they normally have to deal with. In April of that year, Ordinance 53/2013 established what is now called the Joint Commission, a group of experts from different offices to evaluate buildings under protection projects.

The Commission’s aim is to gather in a single board the representatives of the offices that normally supervise any projects on cultural heritage in order to express a joint opinion on their feasibility. There are three areas in which they express their opinions, drawing upon their expertise: the preservation, the improvement of the structural behaviour and the cost congruency. For this reason, the committee consists of a member of the then Technical Structure of the Deputy Commissioner - cost congruity -, a member of Ministry of Culture (hereinafter MiC) - preservation - and a member of the Geological Survey of the Region - improvement of structural behaviour. Among the planned activities there is not only the projects, but also the arrangement of Technical Tables with which to discuss together with the professionals the criticalities found for the cultural heritage project. This character of multidisciplinary and collaboration makes the institution of the commission “*the most innovative experience in terms of process*” (Zuppiroli, 2020), as it has made it possible to streamline a rather difficult process. The agreement at all levels, from technician to the official, of the goals to be achieved and at the same time the gradual improvement of skills and knowledge in the field of restoration and seismic safety of the technical structures have then shown how the establishment of this structure is a successful operation. Undoubtedly the process of cultural heritage reconstruction is still a long-term process that must avoid the “sentimentalism” (Dalla Negra, 2012; 2013) that immediately after a seismic event seems to take over and also requires a long phase of knowledge needed for restoration operations. However, streamlining and shortening the bureaucratic process (three different opinions combined in a single act) has allowed, almost ten years after the earthquake, the cultural heritage to move into the execution phase of the validated projects. Then at the end of

.....  
 6 All references on the current reconstruction status are published in Regione Emilia-Romagna, 2021.

2015, the Commissioner’s Technical Structure was converted into the Regional Agency for Reconstruction - Sisma 2012 (hereinafter just Agency)<sup>7</sup>. This, like the Technical Structure from which it stems, has as its first task the monitoring and coordination of all reconstruction activities, but its work does not end here. In fact, there are four main areas of responsibility of the Agency:

- **Governance and institutional assistance.** As a coordinator, it offers support to the authorities involved in the reconstruction process in order to comply with the principle of consensus, one of the main principles set by the Commissioner<sup>8</sup>.
- **Intervention management and technical assistance.** Here it offers technical support to reconstruction operations. The Joint Commission and the Technical Tables represent the main places where this activity is carried out.
- **Planning for socio-economic development.** In agreement with this action line, the Agency encourages socio-economic development actions in the long-term time. Respecting the concept of unity of intervention, Emilia-Romagna considers the reconstruction process as an opportunity to relaunch the economic system. Moreover, it provides an opportunity to address issues such as the depopulation of historic centres from a wide perspective that does not consider interventions as punctual actions but included within a system.
- **Knowledge capital for resilience.** The experience capitalization is the last of the actions in charge of the Agency. The goal is to transmit the asset of “best practices” acquired during the earthquake management and at the same time identify the weaknesses and attempt to overcome them. It is carried out in agreement with the Emilia-Romagna Research Institutions and Universities. Several European projects have been funded, such as the Interreg Italy-Croatia Firespill project<sup>9</sup> or PhDs like the one in this dissertation (Libro, 2019).

Finally, we cannot forget the great effort made throughout the emergency to ensure total and full transparency in the reconstruction management, both public and private. For this purpose, the Emilia-Romagna Region has, since the beginning, set up a series of tools that would allow, at different scales, to understand the work progress. This activity was carried out through the timely release of reports from six months after the earthquake, and then annually, which can be accessed through the website of the region<sup>10</sup> and through the regular updating of the Openricostruzione website<sup>11</sup>. Opened at the beginning of 2013, the site processes data from MUDE (for housing reconstruction), SFINGE (for business reconstruction) and DURER - Unique Database of Reconstruction of the Emilia-Romagna Region and displays the progress of each project as well as of reconstruction at the municipal level.

The great efforts dedicated to reconstruction have led not only to the conclusion of private reconstruction and to the full executive phase of public reconstruction nine years after the earthquake, but at the same time the crater in which the state of emergency still applies

.....

7 Emilia-Romagna Regional Council Resolution No. 2084/2015.

8 It accomplishes this principle by participating in the Institutional Committee.

9 The project is part of the Safety and Resilience line and has the specific objective to “*increase the safety of the Programme area from natural and man-made disaster*”. <https://www.italy-croatia.eu/web/firespill>

10 <https://www.regione.emilia-romagna.it/terremoto/speciali>

11 <https://openricostruzione.regione.emilia-romagna.it/>



has been reduced over time. To date, there are only about 15 municipalities in the crater compared to the initial 58 (Fig. 8)<sup>12</sup>.

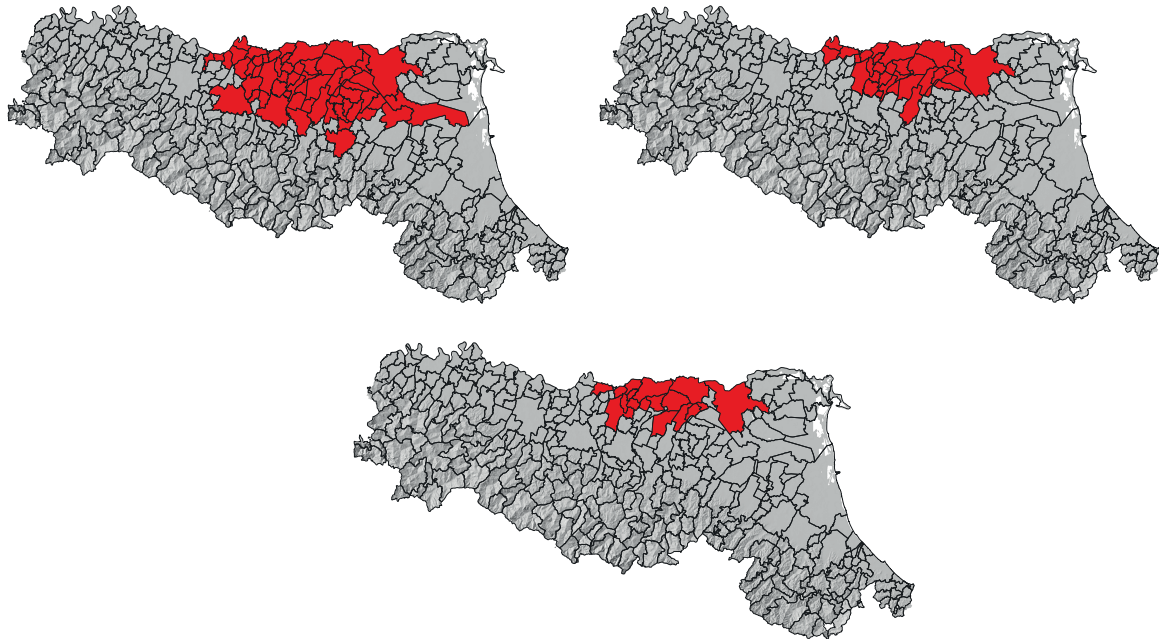

Fig.8. The crater in 2012, 2017 and 2021, less than ten years after the earthquake the reconstruction of the entire system (housing, production activities, schools, etc...) is in such a state of progress as to approach closure.

### ***2.3 Knowledge capital for resilience. The cultural heritage between damage survey and the intervention cost: identification of investigation set and methodology.***

- ***Introduction***

Six years after the earthquake that shook the emilian region, the reconstruction of the cultural heritage was about to start its construction phase. The increasing number of projects submitted, together with the requests for changes in the contributions provided, which have also produced significant changes in the OOPP and BBCC Program, has made it possible to verify and assess the activities undertaken up to that moment. This review has necessarily focused on cultural heritage, whose engagement in the program has ranged over the years between 60% and 79% of planned interventions. For the Program’s placement of the required resources for the restoration, damage repair and seismic improvement of cultural heritage, the Commissioner used the technical evaluations carried out by the UCCR (Di Francesco, 2015).

The progress of the OOPP and BBCC Program execution therefore made it clear that the first damage assessment, which had provided the initial economic estimate for cultural heritage

.....  
<sup>12</sup> A chronology of all the ordinances that followed in the first few months after the earthquake, used also for this chapter, can be found in Capriotti, 2014.

reconstruction, was affected by problems which stem from the survey carried out between 2012 and 2013. Only the huge effort made by the Joint Commission, and in particular by the Agency, has allowed over time to reach the fundability of almost all the buildings included in the program. Indeed, over the years it has carefully examined every single item of the project cost estimates submitted, recovering where possible both resources and successive additional funding<sup>13</sup>. To date, approximately 8% of buildings are not funded by the Program (Fig. 9).

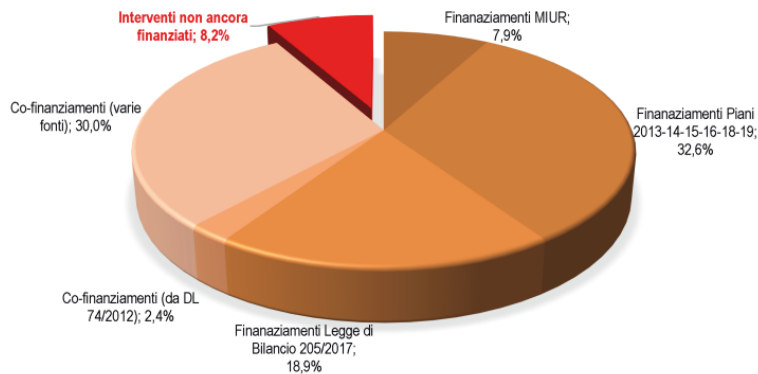

Fig.9. Identification of not fundable intervention percentage (in red) on damaged buildings belonging to Cultural heritage. Extract from Emilia-Romagna Ordinance 17/2021. Source available at: <https://www.regione.emilia-romagna.it/terremoto/gli-atti-per-la-ricostruzione/2021/ordinanza-n-17-del-11-giugno-2021-stcd.pdf>

The criticality faced during the project analysis corroborates what has already been preliminarily exposed by the UCCR officials on the survey activities they conducted and supervised. Accordingly, the survey activities and economic data analysis presented below are aimed at identifying a particular building type which has been highlighted as the most critical issue in the final design by the process of damage survey. This analysis is in accordance with the line of action “Knowledge Capital for Resilience”, promoted by the Agency that funds this PHD for the development of tools that improve the emergency management for cultural heritage. The main aim is to provide a first hypothesis for the development of a damage survey tool that allows an effective intervention in the emergency phase and therefore an accurate economic evaluation of the required damage-recovery funds.

- ***The cultural heritage survey: from operative problems to the databases implementation - resolution of organizational criticalities***

Contrary to the basic building survey, which was almost entirely coordinated and managed during the first emergency by the DPC (carrying out in 60 days the 98% of the basic building surveys), the cultural heritage survey is duty of the MiC. Today, recalling what happened in 1997 in Assisi in the Umbria-Marche emergency<sup>14</sup>, the survey activity is carefully managed and planned before being carried out. Accordingly, on May 20, in connection with the National Crisis Unit and supported by the Carabinieri Command for the Protection of Cultural heritage, the Regional Direction and the Emilia-Romagna Superintendencies worked together to carry out the first recognition of the heritage affected by the earthquake. They needed to be aware of the impact of the event on cultural assets. Already the next day,

.....

13 New funds allocated by the stability pacts, grants from MIUR...

14 Four people died during the visit to the church due to the collapse of Giotto’s frescoed vault after a shake.

the UCCR was informally constituted with its three operative units<sup>15</sup> that actively operated since the first and confused moments.

However, it was on 19 June, almost a month after the earthquake, that the unit for the damage survey to the cultural heritage started the systematic survey of its own heritage. In the first month, several units worked actively to carry out emergency quick visits on-site, to secure the collapsing buildings, to collect and move the artworks at risk and, above all, to systematize all the notifications received about their damaged buildings. In order to optimize the on-site works, the planning of the survey teams activities was the first critical issue faced by the UCCR, whose solution was not only operationally efficient, but of great future potential. This issue, it should be underlined, does not arise in the cases of basic buildings only because the inspection is performed by the DPC teams on the whole building stock (Abruzzo 2009) or only on the owner’s alert (Emilia 2012) regardless of the building type (public, private, protected...). The situation is different in the case of cultural heritage, the real amount of which is hard to quantify even for the offices<sup>16</sup>.

From 20 May onwards, the UCCR therefore faced a series of problems in the survey activities’ planning and the first achievement was the urgent need to connect the assets to their cartographic location. Even when assets were protected by specific restrictions which allowed the identification of the building, the existence of several properties’ names and the lack of information regarding addresses and locations might result in the overlapping both of data and surveys activity on the same building.

It was just after the 2012 earthquake that a GIS-based cartography of areal type<sup>17</sup> was arranged and developed into a well-known webGIS service called the “*Webgis of the Emilia-Romagna Cultural heritage*”. The cultural heritage mapping in the crater area was achieved due to the cooperation of all the municipalities involved in the earthquake, and the intervention of both the UCCR, and the Regional Office, which provided support to several activities. This new cartography therefore enabled both the georeferencing on the CTR of the cultural heritage damaged by the earthquake with their cadastral particles and the assessment of all the property names. A further effort was required to identify all the damaged buildings included in the *Ope legis* protection category which were reported to the Superintendencies. In fact, the authorities that use *Ope legis* building protection are often not really aware of the restrictions imposed, especially when the architecture can be defined as “*minor*” (we refer to buildings of the late nineteenth and early twentieth centuries - Di Cocco, 2014). In these cases, the risk expressed by Mic was that owners operated with inappropriate measures in the best of cases, or with demolition in the worst. For this reason, in circumstances where the assets under protection were unanimously identified in the early days, partly due to the municipalities’ cooperation, the priority was to identify damaged public buildings protected by *Ope legis* as quickly and extensively as possible. With the Region’s

.....  
15 Officially established with DDR 43 of 2012 on June 7. The three nuclei of which it is composed are the Regional Coordination UCR, the Survey of damages to Cultural heritage Unit and the Technical Coordination Unit of Safety Measures.

16 Apart from the decree-bound buildings, which are easily identifiable, all public assets protected *Ope legis* (i.e. by virtue of the age of construction fixed at least at 70 years) must be considered cultural heritage, unless a so-called Verification of Cultural Interest is carried out.

17 A georeferencing of punctual type was already existing in 2012 and was represented by the data contained in the Risk Map. However, this cartography was not updated (last update was in 2004).

support, the database of the AeDES forms was analysed in order to extract those forms concerning public buildings (2836 forms). These forms were then processed individually and almost 300 applications of damaged cultural heritage were identified which had not been reported to the Ministry.

The GIS database setup allowed for damage survey activities to start on June 19th. By providing accurate areal localization of the damaged buildings, it enhanced the work of several teams which carried out building inspections at an average of 5 teams per week in the first 6 months (Di Cocco, 2014). Unlike on other occasions, the extensive work carried out in this phase to allow streamlined emergency management has not been abandoned, but over time has been enriched with new elements. Once the surveys were reached, the data collected were added to information in an alphanumeric database. Over time, the information for each building was implemented by inserting links related to the Networked Restriction system, the National Archives system, and even to the library centers where the main bibliography is located. It is a remarkable project that is not yet concluded, but is in steady development and continuously being updated, with many innovative aspects in the GIS-for-cultural heritage panorama<sup>18</sup>.

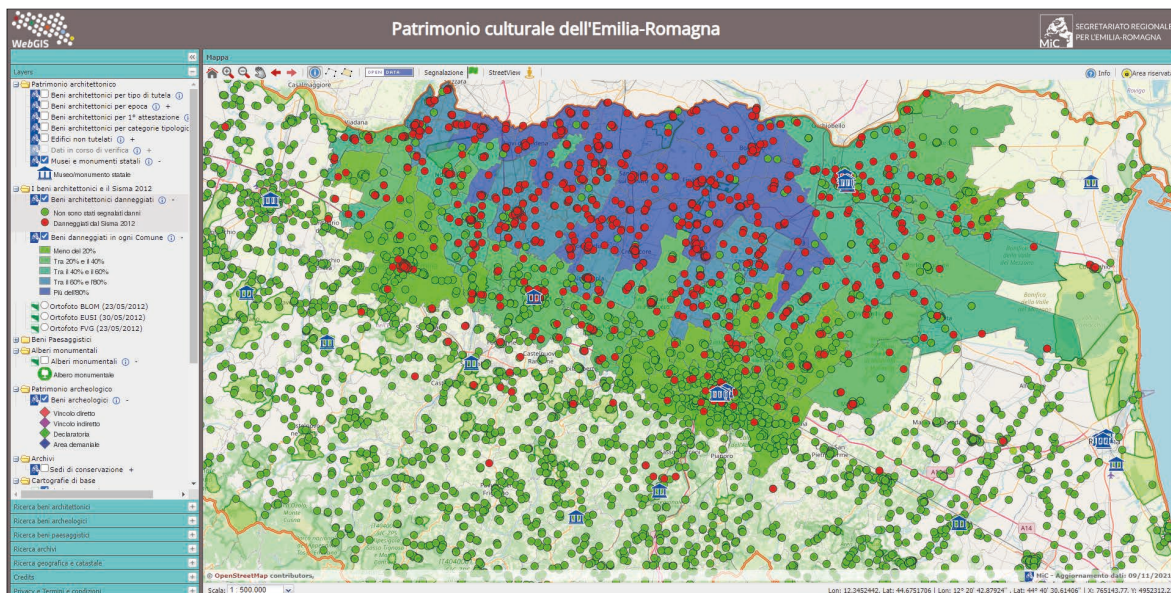

Fig. 10. Image extracted from the web gis of the Cultural heritage of Emilia-Romagna: in red the assets damaged by the earthquake, from blue to green indicating the percentage of damaged cultural assets (blue>80% green<20%) in the crater municipalities.

The only element on which further reflection would be necessary are the codes of the inventoried assets. When the first database was set up, a cataloguing code was created and it was made up of the municipality ISTAT code, followed by an underscore and the number of the asset in the Superintendency list; in other words, a new alphanumeric code of a strictly regional nature was generated. Although this code is “speaking” (Di Cocco, 2014), it seems to have missed the opportunity to start a dialogue between territorial information systems belonging to different institutions by using already existing codes, regional or national.

An example of which is represented by the codes attributed to the buildings by the CLE

.....

<sup>18</sup> In Italy the cultural heritage GIS scenario is wide and includes both GIS at territorial level and at the scale of the individual building. As an example, in addition to the already mentioned Risk Map GIS, we can mention SIGECweb of the ICCD, also at territorial scale, or SICaR/WB at the building scale.

Analysis. These codes, which contain a numerical sequence identifying the building stock and the number of buildings within it, in addition to the ID for regions, provinces, and municipalities, are not of regional but of national relevance. The use of such an identifier would then have allowed for the dialogue of this database with the results of the CLE, which often involve cultural heritage as strategic buildings, but also with other systems adopting this coding at the national level. This is probably the reason why The Emilia-Romagna Region, which in recent years has developed several CLEs, has maintained the use of this code in its mapping. Such a development in the GIS systems’ structure would allow for a more integrated management of databases that today only rarely leave the sphere of the authority in charge of it.

- ***The cultural heritage survey: not solved criticalities***

On June 19, teams composed of a superintendence official, a firefighter and a structural engineer started their damage survey of architectural heritage. In compliance with the provisions of Ministerial Decree 23/2006, the damage survey was carried out using the A-DC form and B-DP form, for Churches and Stately Buildings respectively. After an initial moment in which teams were asked to complete all sections of the forms, a further procedural innovation was experimented with regards to the economic assessment of the damage. The task of estimating the intervention cost based on the A-DC and B-DP data was assigned to a Validation Group specifically established for this purpose. Therefore, in order to identify the financial needs resulting from the damage, the working group studied the parameters to be referred to in the forms’ analysis. The aim was twofold

- To avoid any teams’ corrections in the forms to direct the estimate towards a cost considered more consistent with subjective assessments<sup>19</sup>.
- To entrust the economic assessment to a single group in order to enable the outcomes to be comparable for each asset.

The limit of such a choice is, however, in the reliability of the survey. If the economic assessment is not carried out by those who fill out the forms and personally detect the damage, the lack of correct damage representation in the specific models results in an incorrect subsequent identification of the necessary economic resources. Six months after the earthquake, when the damage survey was not yet concluded, but approximately two-thirds done, the first considerations on the progress of the activities started, identifying the criticalities to which it was impossible to give an effective solution and which therefore influenced the process of economic validation. These critical points revealed two types of problems.

The first main problem concerned the use of the B-DP form in a general sense. As already stated in the previous chapter, over time the form has shown its lack of effectiveness in the emergency phase. Architect Di Francesco, in charge of the Regional Coordination Unit, defined the tool as “*suitable for study use, but certainly not in such situations as those we are facing*” (Di Francesco, 2014:37). To overcome the criticalities connected with this instrument, during the 2012 emergency, a simplified instrument was tested which was intended to facilitate surveying operations at the expense of a reduced information gathering capacity. It is not possible here to analyse its application to the *Stately Building type*, the

.....

<sup>19</sup> Any survey operation cannot be considered unbiased, especially the damage survey which depends on the recognition of collapse mechanisms. However, the aim is to obtain data which are increasingly reliable and close to the idea of objectivity.

*type* for which the B-DP form was designed. However, it is possible to outline some general observations. First of all, in 2012, the filling in of this tool was probably easier for the survey teams. Indeed, the simplified form corresponded to an internal document that explains its structure, i.e., it had a sort of “manual” unlike the B-DP form. From the point of view of the simplifications, however, the relevance of some removed data is not fully understood. As an example, if it is true that the detailed survey of each structural element might be considered unnecessary, or that the identification of the collapse mechanisms and of the relative state of damage, as formulated, does not clearly indicate which are the parameters “d” and “N” for damage index calculation, therefore necessitating a general rethink of both content and form, then the removal of the data concerning the materials reveals a lack of awareness of the tool potentiality. In fact, being the masonry-type data associated with the seismic resistance of the masonry types, it is still useful data for any vulnerability assessment. However, at the end of this test, the general outcome must not have been satisfactory, as in 2016, after the Central Italy earthquake, the model previously used was the approved B-DP form. Despite this, the experimentation should not be considered as a “defeat” from the point of view of the tool, but as a necessary mediation step in achieving an effective tool.

The second issue, raised in 2012, concerned the presence within the damaged heritage of many buildings not belonging to the two building types for which the forms had been designed. They were detected with the existing tools only with several simplifications (Di Francesco, 2014:37). The initial focus on churches was due to their tendency to be damaged even by low-intensity earthquakes. This feature, together with the high-density of religious buildings in Italy, led to them being a priority for investigation from the late 1980s onwards. At the beginning of the year 2000, when the model adopted was defined, the focus turned to the *Stately Building type* to which another large number of buildings undoubtedly belonged. However, no further studies were conducted, although it was clearly expressed already in those years that similar studies could be carried out for other *building types* (Lagomarsino & Podestà, 2005).

Already visible in 2012, but still more evident with the execution of OOPP and BBCC Program, it appears that, although statistically less relevant in the monumental building landscape, damage to buildings other than churches or palaces has a significant social and economic impact on reconstruction. This impact, in a financial view, is even more negative when the available surveying tools are unable to correctly assess their structural and seismic behaviour<sup>20</sup>.

- ***Aim and object of study identification: damaged types and selection criteria***

In order to address the recovery policies of cultural heritage towards more sustainable interventions, the aim of this research is to improve the procedures of damage survey, both in the emergency phase and in terms of risk mitigation. As previously stated, after the earthquake, the damaged cultural heritage included a large number of buildings differing in their typological-constructive features and therefore in their structural seismic response. Even if they represented almost one third of the cultural assets affected by the earthquake, no scheduling model has been provided to allow the acquisition of their damage.

.....  
<sup>20</sup> A summary assessment of the damage in the Emilia 2012 earthquake with reference also to cultural assets is present in Borghesi et al., 2014.

Considering that, although the B-DP form is not user-friendly, it still offers a response model that can be applied even in an emergency phase despite the lack of speed, and considering the large number of buildings without an approved scheduling model, it has been decided to focus on the buildings included in this set in order to reduce the impact of a lack of damage data on the whole set. All cultural heritage types damaged by the 2012 earthquake were then examined in order to identify the sample for the following study. The typological characterization was carried out using the classifications already made by the UCCR and included as an *opendata* inside the *Webgis of the Emilia-Romagna Cultural heritage in 2018*<sup>21</sup>. A first classification had already been published in 2015 (Di Francesco, 2014).

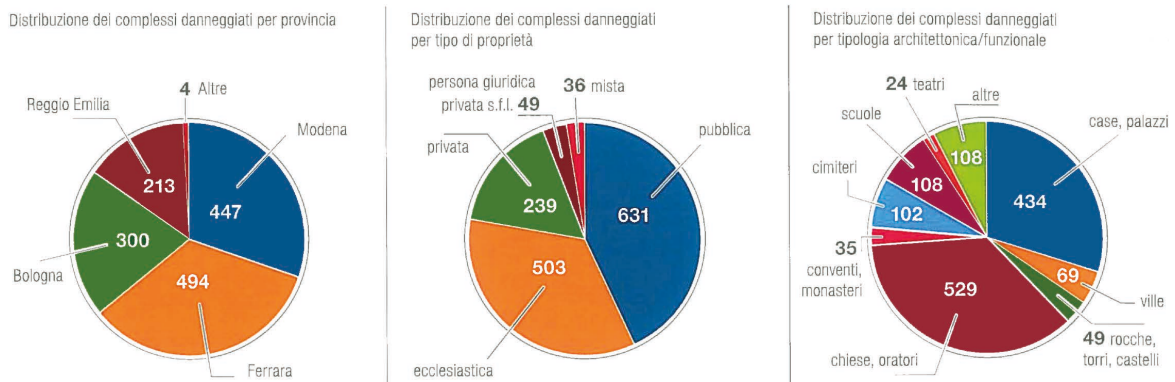

Fig.11. Identification of damaged Cultural heritage by type carried out by MiC (Di Francesco, 2014: 181).

The criteria used to judge the heritage of this group are as follows:

- Numerosity of the samples and the validation of the typological homogeneity of the Mic classification.
- Damage tendency.
- Impact of the damage on communities.
- Agency’s desiderata.

Following types analysis according to these criteria, the type to be investigated was identified.

**Numerosity of the samples.** Damage analysis is based on the observed phenomena occurring on the buildings as a result of the earthquake. This activity requires a large number of damaged buildings belonging to the same type in order to consider the results reliable. Indeed, the damage modes listed in the scheduling tools, A-DC and B-DP forms, identify the typical damage modes of all structures belonging to the type and not specific damages caused by particular structural features. Therefore, to achieve this objective, numerous damages need to be assessed to determine which may be considered recurrent. The criterion of numerosity is therefore fundamental for the identification of recurrent collapse mechanisms. Regarding this criterion, the absolute number of damaged buildings by type was taken into account. The survey was carried out according to the buildings’ class clusters provided by the MiC. As can be seen in Chart 1, from the point of view of the number, it is clear that

.....  
 21 The ongoing development of the Webgis of the Cultural heritage of Emilia-Romagna is not only expressed in the data-update but also in the evaluation of the open-data that can be transmitted. So, if in 2018 it was possible to download a dataset containing several fields with increasing specificity regarding the type, today this option has been restricted to a dataset containing only the field named “category”.

also in the 2012 earthquake the cultural heritage that mostly suffered were the churches first, and then the Stately Buildings. Although, the numerical relevance of the other building typologies is considerably lower compared to these two categories, the analysis of the table shows that the other most relevant samples are schools and cemeteries. They are followed by the other category, fortresses/castles and towers, monasteries, and finally, almost on the same level, hydraulic constructions and theatres.

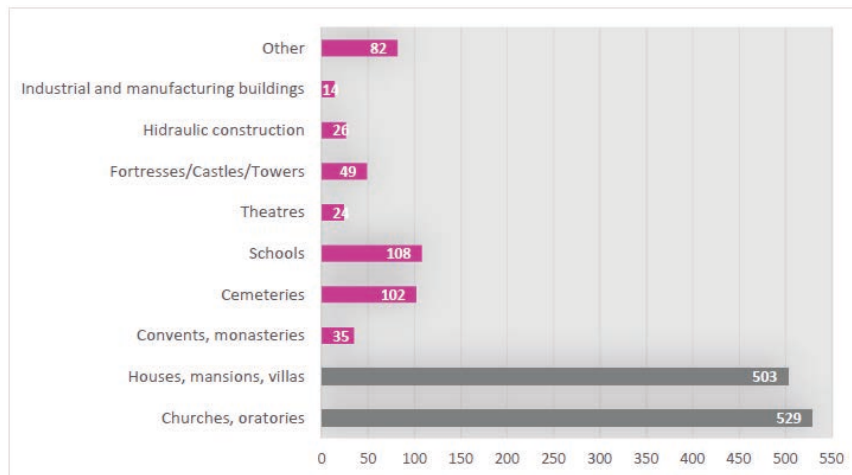

Chart 1. Number of damaged buildings by type

**Typological homogeneity.** The criterion estimates the homogeneity of the constructive and typological features of the several types identified by the ministry database. This property is very relevant for the effectiveness of the tool. If we consider the B-DP form, the production of several descriptive sections to allow many configurations is among the design reasons but at the same time contributes to the failure of the approved tool. The decision to include all non-religious structures in a single form, without any discrimination by *type*, has already demonstrated its ineffectiveness in the earthquakes that have occurred since 2009 (Modena & Binda, 2009). With regard to this criterion, from the analysis of the ministerial database, it can be underlined that:

- In the “other” category, all the damaged buildings with less than 5 cases per type are grouped. They range from colonnades to stables and arcades but also barracks and prisons protected by *Ope legis*. Thus, sample homogeneity is **zero**.
- In the “manufacturing and productive buildings” category several types of buildings are grouped together, from slaughterhouses to service outbuildings. The homogeneity of the sample is **low**.
- In the category “hydraulic constructions” are grouped mills, piezometric towers, and the other artifacts for water-management. The homogeneity of the sample is therefore **low**.
- In the category “Fortresses/Castles/Towers”, they are grouped together with several types of buildings. For instance, the group also includes mansions. Considering the functional variance to which different seismic behaviours correspond, the homogeneity of the sample can be considered as medium-low. However, the data can also be subdivided into **different homogeneous categories** identifying statistically less relevant but more homogeneous samples. Additionally, with regard to the type tower, it should be removed from the analysed group, as its behaviour conforms to the seismic dynamics of the bell towers included in the churches form.



- The “theaters” category mainly includes municipal and/or parish theaters, with the exception of a small number of buildings created by adapting other constructions. The sample can be considered **homogeneous**.
- In the “school” category there are buildings of every type and school grade, even buildings adapted to perform this function (*casa del fascio*, palaces, etc.). Considering the similar structural behaviour of these buildings we can consider the sample **averagely homogeneous**.
- “Cemeteries” category includes only cemetery sites. The sample is **homogeneous**.
- In the category “convents/monasteries” only such buildings can be found, even if they are often extensively renovated to accommodate new functions (schools, court ...). The sample is **homogeneous**.

In conclusion to such a check, the result about investigable sets for the abovementioned points is defined as follows:

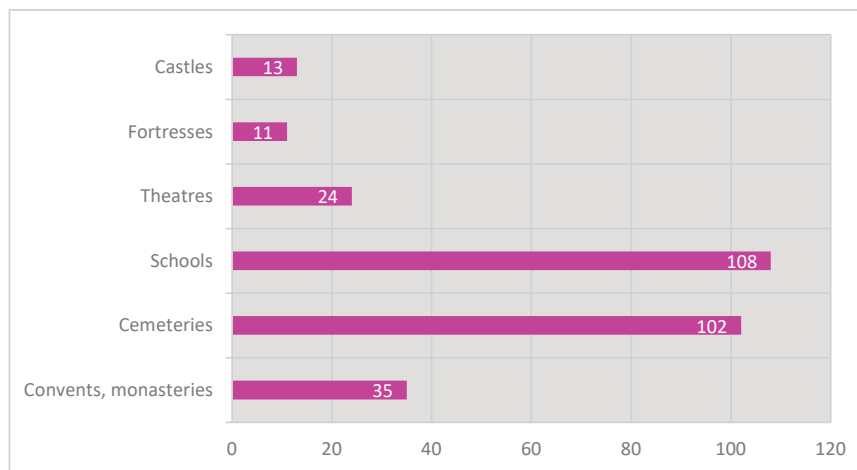

Chart 2. Number of damaged buildings by type for almost homogeneous categories

**Cemeteries and Schools** result in the samples with the greatest number of damaged buildings within the set not detectable by A-DC and B-DP forms.

**Damage tendency.** This criterion aims at rapidly assessing the damage tendency of structures by their *type*. In order to identify the best study sample, not only is it important to assess the number of damaged assets, but also the percentage they represent within the total set of damaged assets for the *type*. The rating is carried out by identifying the ratio expressed as a percentage between the number of assets damaged by the earthquake for each type of Chart 2 and the total number of assets located within the crater area (Tab. 1). Thus, the ratio expresses the greater or lesser tendency to damage expressed by each type.

	damaged building	total buildings in crater area	Ratio (%)
Castles	13	18	<b>72</b>
Fortresses	11	13	<b>85</b>
Theatres	24	38	<b>63</b>
Schools	108	206	<b>52</b>
Cemeteries	102	145	<b>70</b>
Convents, monasteries	35	98	<b>36</b>

Tab 1. Ratio between damage buildings and total buildings in crater area

From the damage tendency criterion perspective, the most vulnerable to earthquakes are the **Fortresses** with a damage rate of 85% of the buildings in the crater area, followed by Castles and Cemeteries with about 70%. Then we can consider the Theatres with 63%, and finally schools and monasteries

**Impact of the damage on communities.** This criterion assesses the different impacts that the damaged cultural heritage produces on communities. We can consider three relevant parameters:

- Cultural impact. Defined as the loss of a symbolic place for the community.
- Social impact. Defined as the impact of the damage on essential functions for the community.
- Hygienic-sanitary impact.

This criterion is relevant in identifying a list of investigation priorities. It, however, should not be intended as an intervention priority list in terms of risk mitigation or reconstruction process, since such a list can be drawn up only by taking into consideration other factors, such as crowding, external risks and more.

The impacts observed on the different types examined are:

- Castles: **cultural impact**. The damage to castles is strongly recognized as the loss of the places’ history and identity.
- Forts: **cultural impact**. Damage to fortresses is strongly recognized as the loss of the places’ history and identity.
- Theatres: **cultural impact**. The damage to theatres is recognized as a loss of the places’ history and identity. The loss of a social function is also perceived, but this function is not considered strictly essential.
- Schools: **social impact**. The damage derived from the loss of the teaching function. Only in rare cases damage of a cultural nature is also perceived.
- Cemeteries: **cultural, social, and sanitary impact**. Damage to cemeteries is perceived as a health and hygiene problem in the first emergency. In addition, there is a social damage, since the function hosted cannot be displaced elsewhere, and a cultural damage, since it is perceived as a loss of a collective place.
- Monasteries: **cultural impact**. Damage to monasteries is generally perceived as a significant loss in history and identity of places. This perception increases in relation to the damage of churches adjacent to them.

In conclusion, the greatest impact on the community from type damage is from **cemeteries**, then schools and theatres, and finally monasteries, fortresses, and castles

**Agency’s desiderata.** This research is funded by the Emilia-Romagna Region and has been specifically supported by the Agency, which has among its main purposes both the investigation of the criticality of the Emilia-2012 earthquake, and the communication and sharing of best practices. Among the verification criteria, in case of a tie, the Agency’s preliminary selection was therefore taken into account. **Fortresses, theatres and cemeteries** were highlighted as relevant types in the regional analyses. Indeed, these three types were identified as the

least detectable through existing forms, as well as having the greatest economic impact on the OOPP and BBCC Program, both in total cost (cemeteries with 59,000,000 euros), and in terms of average cost per intervention (fortresses 3,000,000 euros/intervention and theatres 2,000,000 euros/intervention).

**Conclusions.** For an easy interpretation, the results of the different selection criteria have been reported in a table (Tab 2). For each type investigated the correspondence to the criteria abovementioned has been identified according to a colour rating scale with high, medium and low corresponding to red, yellow and green respectively.

	monasteries	cemeteries	schools	theatres	fortresses	castles
criteraion 1	yellow	green	green	yellow	red	red
criteraion 2	red	yellow	red	yellow	green	yellow
criteraion 3	red	green	yellow	yellow	red	red
criteraion 4	red	green	red	green	green	green

Tab 2. Summary of *type* and criteria correspondence

As shown above, the *type* that fullfills the most criteria is the ***cemetery type***. It is therefore **selected as the subject of the investigation** in the research presented in this thesis.

- ***Methodology***

In line with the main goal of the research, this thesis aims to identify and analyse data from different categories, all pertaining to the cemetery type, in order to detect the data useful for the tools and resources implementation in terms of both the seismic risk mitigation and the support in the emergency phase.

Each category was analysed using different approaches depending on the data type evaluated. The data was grouped into three macro-categories renamed, in line with the definition of Risk, Exposure or Exposed Value, Vulnerability and Hazard.

$$R = E \times V \times P$$

**Exposure** = Exposure or exposed value indicates the value of what may be negatively affected by a seismic event and on which the seismic risk analysis is performed (Bramerini et al., 2008). In the Exposure nomenclature the data collected comes from historical and typological analysis. Starting from the most general definition of a cemetery, they identify the historical and social value of the type and the typological development. Structural invariances and classifications useful for the semantic structuring of a compound organism such as the cemetery have been identified from these data. The results of the analyses are presented mainly in Chapter 3.

**Vulnerability**= The vulnerability is the tendency to suffer damage as a result of the stresses induced by an earthquake of a specific magnitude. In this nomenclature all the data produced by the Emilia 2012 earthquake has been grouped. The data analysis provides a basis for earthquake damage observational and statistical investigations in order to identify recurrent collapse mechanisms for the type. Starting with investigations of observed damage for the sample, recurrent mechanisms were identified by generalising and associating them with

the type. According to a bottom-up approach, the mechanisms identified will be included in a new scheduling tool to be added to the existing ones during the emergency survey operations. This analysis is outlined in Chapter 4.

In addition, by integrating the two categories of data, an analysis was carried out to determine a protocol for defining the cemetery vulnerability assessment. This protocol, properly integrated in the damage survey tool, is designed as an additional support for decision-making operations of seismic risk mitigation. This analysis is outlined in Chapter 5.

In this case, we can refer to a bottom-up approach as data from a specific dataset (of damage or of vulnerability) will form a base for more general definitions.

**Seismic hazard** = Quantitative estimate of ground shaking due to seismic activity in a selecte area (Bramerini et al., 2008). This category includes data from studies carried out by the Geological Seismic and Soil Service, DPC, and INGV about the seismic maps for the May 20 and 29 events, seismic macro-intensity by municipality, or geology, etc. Data from this class were used both to support analyses carried out with data from other categories, such as for vulnerability assessments, and to support the GIS information system project for cemetery type.

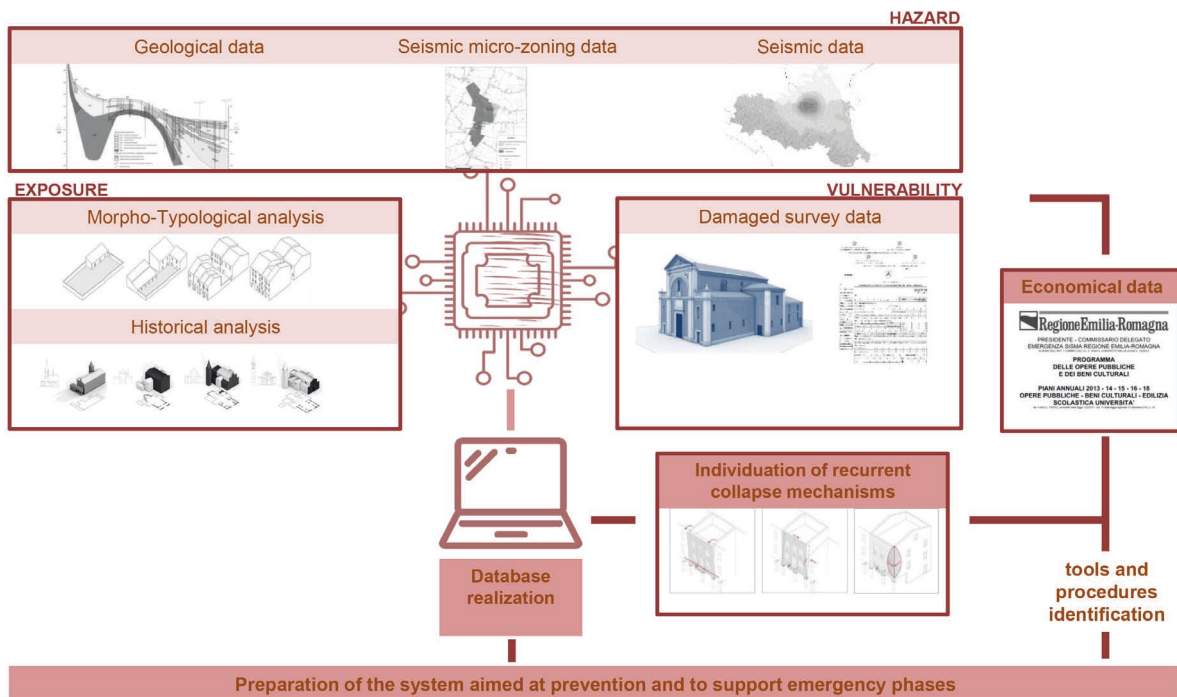

Fig.12. Conceptual methodology scheme

As a result, it produced a draft of a first-level scheduling tool attached to a territorial information system that can be integrated with the existing regional system. Today only partially tested, it could be implemented and verified after the following earthquake.