

# ***CHAPTER 3***

## ***Type interpreting: the cemetery type***



On the previous page a columbarium in the cemiterio de Agramonte, Porto, Portugal.

### 3.1 General framework for the typological interpretation of cemeteries

The data analysed in this chapter, defined as belonging to the exposed value category, i.e. the value of assets subject to risk, are of fundamental importance for identifying the typical features that allow interpretation in a seismic-structural key. The data are obtained from the historical, morpho-typological and constructive analysis of cemeteries.

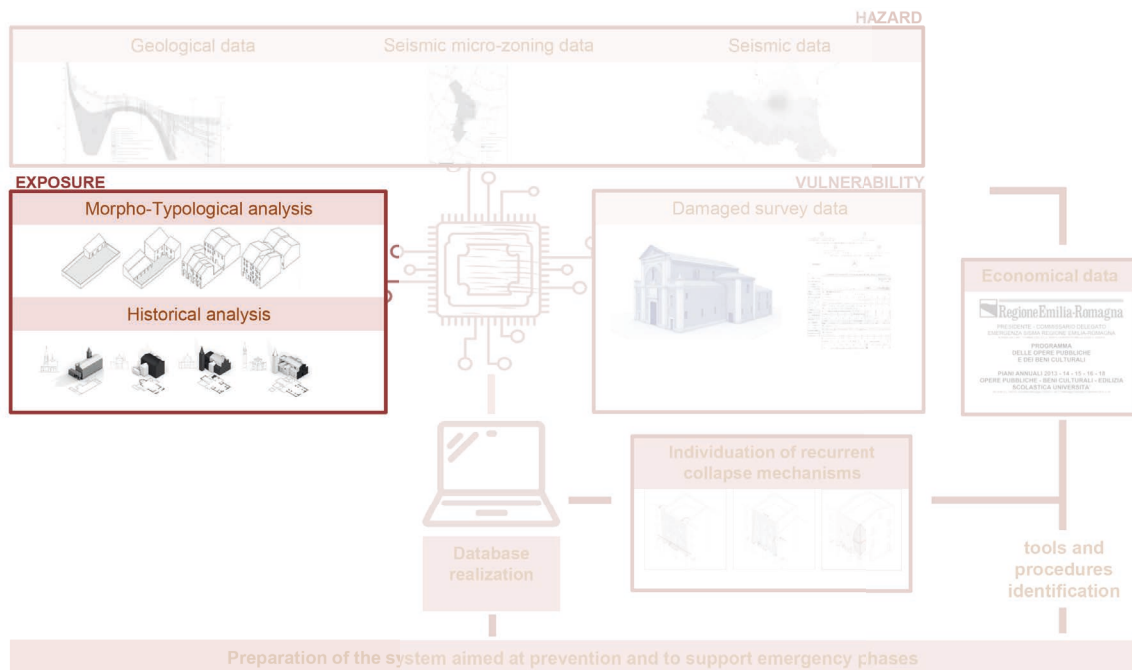

Excluding the identification of the constructive features of buildings, which depend on where said buildings are located, the other analyses are of general validity within the Italian scenario (although a broader geographical scenario is also considered). The relevance of typological analyses to the vulnerability of historical buildings was first introduced in the research carried out by Antonino Giuffrè's group (Giuffrè, 1988). On that occasion, he illustrated how typological interpreting in a developmental sense, an approach introduced with the school of Muratori and his first- and second-generation students (Muratori, 1960; 1963; Caniggia, 1976; Caniggia & Maffei, 1979; 1984; Capelli, 1986; Cataldi, 1977; Dalla Negra, 2017), was fundamental for understanding the intrinsic weaknesses of urban nuclei. Indeed, this is one of the most innovative outcomes of the Muratorian school and is referred to in the present research: the concept of *building typology* not as a static classification but a more process-oriented and developmental view (*Procedural typology*). The typological approach is therefore not referring to the methods used to assess vulnerability<sup>1</sup>, related to a static building classification, but to typological interpretation in a *diachronic* and *diatopic* sense, in order to understand the rules, spontaneous or otherwise, of its development. Only through what is called a "*phenomenological-structural reading*" can we identify those "*permanent and changing rules*" (Dalla Negra & Zuppiroli, 2012) that enable us to interpret

.....  
 1 Vulnerability analyses of level 0 are based on static typological classifications.

an organisms' composition<sup>2</sup>. These rules provide the framework within which it is possible to carry out structural seismic assessment, partly due to the inputs from studies on construction techniques (Carocci & Lagomarsino 2009; Carocci, 2012; Giuffrida et al., 2019) with which these rules materialise, from time to time, in different geographical areas. An interpretation not only defined by Giuffrè as “*not useless*” at knowledge level but also closely related to the structural construction of buildings (Giuffrè, 1993:5). Specifically with regard to cemeteries, the edict of Saint Cloud is generally accepted as the dividing event between the modern cemetery and its predecessors. The relationship between existing cemeteries and those of new formation is now relegated, when allowed, to a hypothetical identification of models from which to draw “*inspiration*” (de Quincy, 1788:677-683)<sup>3</sup>.

New cemeteries are seen as urban or architectural episodes to be assigned to defined classes that seem to be disjointed, so, for example, the German cemetery seems to be totally different from the British one and the latter is totally unrelated to the American one<sup>4</sup>. If, however, one examines in a *diachronic mode* the changes in the *cemetery type* from the Middle Ages to the present day in the West, it becomes clear that it is possible to interpret the transformations that have involved it in a procedural sense and to identify, for example, the common matrix of the three cemeteries mentioned above. This interpretation, when properly addressed, can break down the building into its main components and offer an understanding of the growth phenomena in order to make assessments on homogeneous areas both from an architectural and structural point of view.

Closely connected to this analysis, but more related to different local conditions, there is also the analysis of constructive features. By identifying the ways in which the morpho-typological characteristics of the type are expressed in the different areas, this enables to identify the vulnerability of buildings or measures to mitigate it. They can be classified into “*intrinsic vulnerabilities*”, i.e., those constructive or architectural features of the original construction, such as large vaulted spaces, or “*transformation vulnerabilities*”(Carocci, 2013:141-142), i.e., resulting from human interventions over the centuries that have compromised the building's integrity. An analysis of these vulnerabilities, and of the resilience factors, whether it is conducted extensively on a whole urban nucleus or on a specific *type* in a given area, allows the definition of informative maps to establish intervention criteria for risk mitigation (Giuffrida et al., 2019 ).

A brief excerpt from the “*critical glossary*”, edited by Arch. Nicola Marzot, of the main terms of reference for the typological interpreting is reported below ( Caniggia & Maffei, 2018:209-224; Maffei & Maffei, 2017: 309-315):

**BASIC BUILDINGS.** The materialisation of a sequence of building types, determined according to ‘spontaneous consciousness’, within the same cultural area, appertaining to housing and private property.

**CRITICAL CONSCIOUSNESS.** The conditions of uncertainty in which a person or agent

.....

2 We use the word organism here with reference as much to the city, on which many studies have been conducted, as to the cemetery which, by no mere coincidence, can be defined as “the city of the dead”.

3 “CIMETIERE” definition.

4 For example, Ragon draws up a cemetery classification in which only at the most recent seems to admit a confluence of all the “cemetery types” identified towards a new model, the landscape cemetery (Ragon, 1986).

acts when their cultural horizon is lacking due to the sudden onset of a state of crisis. This results in the gradual de-legitimisation and questioning of construction conventions established during the previous phase of 'spontaneous consciousness' in preference for a number of options of 'what should be done' that implies the need to choose from the possible alternatives.

**INTERPRETATION.** Our understanding of reality does not require the passive acceptance of the existing world. If anything, it involves an intimate phenomenological-existential relationship between a 'knowing' agent, or 'subject', and the object that is being 'known', i.e. between behaviour and reaction. As a result, they do not manifest themselves 'separately' before that meeting, instead they 'reciprocally' manifest themselves through it. This implies the psychophysical unity of the learning process, which involves the entire body and links the sensory data gained from experience to its intelligible conceptualisation. This link is made possible by our ability to select pieces of information - grouping them into 'classes' on the basis of similarities that are heuristically discoverable using elementary archetypal parameters of behaviour - and subsequently group them according to relationships of reciprocal complexity. In such circumstances, the act of attributing the moment of interpretation with the value of a conventional synthesis between a 'subject', i.e. an agent's 'intentions' and 'tools', employed in its pursuit, and the 'aptitudes' and 'codes' of an 'object' takes on particular meaning. While the former translates real behaviours into 'entities' and 'relationships' of abstract reciprocity, no matter how 'extracted' they are from it, the latter similarly exchanges reactions for their relative 'components' and 'proportions'. The yield when interpreting reality is therefore directly proportional to the reciprocal implications of the abovementioned factors.

**NODALITY.** Nodal buildings are those of the highest value in a manmade settlement, both in economic and political terms. This label can be applied at all levels of interpretation of the manmade world; within a city block, there is always a more nodal area, such as that which looks out onto a city square, just as there will be a similar difference in nodality when it comes to a district, a city or a region.

**POLE-POLARITY.** This concept expresses the quality of a point considered part of a Continuous and uniform space, which is the start or end point of any continuous spaces. To some extent, it represents a sublimation of the concept of 'node'.

**SPECIALISED BUILDINGS.** Non-residential buildings created through the application of a particular kind of 'critical consciousness' to private building, from which they originate- thus in actual fact creating a specialisation' of them whilst retaining an imprint of them - through a process of change that makes them suitable for public use. More precisely, the term expresses the intentional sublimation of their conventional characteristics, which are, in any case, found in the design of building types.

**SPONTANEOUS CONSCIOUSNESS.** The conditions of relative stability in which a person or agent acts within a system of rules accepted by the community to which he or she belongs, in line with corresponding values. This implies the existence of a building culture that has been inherited through a process over time and space, i.e. historically founded in those particular manmade circumstances that – with the consolidation of human experience and the conceptual processing of data derived from such experience- define a place.

**TYPE.** The conventionally accepted system of rules adopted in a responsible way as a principle legitimising civil work. It believed to be historically founded on a common experience in 'doing/making', gradually gained by the members of a community over time and in a particular place, through the process of altering the natural and/or built environment. Type allows us to tackle a problem assigned to us by referring to a heritage of unified and consistent knowledge, in keeping with what has already been tried in similar circumstances.

**TYOLOGICAL SERIES.** This term identifies the categories of specialised building that differ according to the type of service they are designed to provide. A series evolves in line with the concept of typological process: over time, an older specialised building undergoes a gradual series of changes that can create partially or entirely different buildings of the same building type. Such a iterations can occur for technical reasons (a technological breakthrough, for example), or due to a different geographic location, i.e. a cultural area. In order to exemplify changes in use, one need only consider Roman basilicas, which evolved from buildings previously used as legal courts into Christian churches. In contrast, hospital are obvious examples of how the evolution of techniques and technologies can, over time, create buildings that have an entirely different shape but the same purpose (from the early medieval hermitage to today hospitals).

**VARIANT/MUTATION.** These are non-'structural' changes to the building type, and are instead 'situation-dependent', determined by the need to adapt to new uses. To this end, they do not result in a change in the concept of 'dwelling/inhabiting' associated with particular space/time conditions, and are not enough to transform or entirely replace it.

## **3.2 Historical and architectural framework**

### *The "cemetery" before the cemetery*

The concept of the cemetery as a consolidated common space has developed since the advent of Christianity. Before that time, burial places, while being able to accommodate more graves - or more bodies - were in peripheral areas, located along the main roads outside the city walls or on land - always external - where private burials took place according to the contemporary practices. They were devoid of the features of what was later called a cemetery, literally a place of rest ( Treccani, 1979), since in archaic times burial practices were only aimed at disposing of the rotting body and removing it from the space where people lived.

The archetypal house-tomb relationship, still present today, has always been an integral part of burial practices, even those of an archaic nature which built burial tombs with gabled roofs, symbolic doors, and more. What slowly changes with Christianity is the relationship with the dead corpse, no longer seen as something to be removed from the city but as something to be preserved. It is precisely this desire to "preserve the corpse" that, in the Western world, determined the phenomenon of the burial's concentration inside a space with specific qualities and symbolic significances. However, it did not represent a clear break with the previous system but is the result of a gradual and long-term cultural and religious change (Aries, 1977). Consequently, in a first phase, christian cemeteries overlapped with the *extra-muros* pagan burial grounds. In the first century A.D., the corpse was still perceived as something to be kept at a distance from the collective space, according to

previous pagan beliefs. Christians of the time used the same areas that had been used until then. This perception, however, was lost with the strengthening of christian eschatology and the belief in the resurrection. Mortal remains were converted into something to be safeguarded in anticipation of Judgment Day and the resurrection of the righteous. This new feeling within the communities led to the renovation of the burial space resulting in the establishment of the medieval cemetery.

### The medieval cemetery (V- XVIII sec)

The image of the medieval cemetery is undoubtedly something totally foreign to the contemporary vision: large fenced-in spaces with bones laid out to dry under the arcades that ran along them, or crammed on top of them, human remains emerging from the ground and social life flowing quietly alongside the funeral services, apparently unaware of where they were located (Fig. 1). This image arouses repulsion in contemporary man, a feeling undoubtedly unknown to the men of that era considering the sense of “*indifferent familiarity*” (Aries, 1977) towards death and the dead which characterized the culture in those centuries.



Fig.1. The Saint Innocent cemetery around the 1500. Paint of Theodor Josef Hubert Hoffbauer. Source available at: [https://it.wikipedia.org/wiki/Cimitero\\_degli\\_Innocenti](https://it.wikipedia.org/wiki/Cimitero_degli_Innocenti)

Nevertheless, contemporary philosophy, closer in some formulations to the pre-Christian period, retains some of the socio-cultural aspects that turned the space for the dead into the cemetery from the fifth century. This term in fact, in addition to its funerary meaning, was endowed with additional meanings that led to its architectural and social definition.

As far as funerary meanings are concerned, if we refer to what is written in Du Cange's<sup>5</sup> glossary (1710), the *cimiterium*, is the "*locus in quo humantur fidelium corpora*" as much as the "*ecclesia, in qua scilicet fidelium corpora humantur*". This means that the cemetery is not only the place where the bodies of the faithful are buried, but also the church. Du Cange's reference is related to a phenomenon that was to be associated with the cemetery space, the overlap between cemetery and church, from the seventh to the eighteenth century. The two spaces, initially separate, became blurred until the latter prevailed over the former.

But the *cimiterium* is also *area ante aedem sacram, idem quod Atrium*. Like *cimiterium* and *ecclesia*, *cimiterium* and *atrium* were also synonymous during these centuries<sup>6</sup>. The medieval cemetery was the churchyard or, more generally, the enclosure next to it. This enclosure could have one side coinciding with the church itself and the other three consisting of a series of loggias or arcades that housed the ossuaries in the area above, or a simple open area surrounded by a low wall or fence, generally quite large and therefore built outside the towns. Both models enclosed large mass graves.

Until the nineteenth century, burials were collective. Contrary to Roman times in which they usually had a funerary inscription showing both name and age, from the Middle Ages, the practice of funerary inscriptions was the privilege of saints, clergymen and famous men and, even in this case, the funerary inscription could not indicate the presence of the remains in the same place<sup>7</sup>. It is also worth noting that the second model of medieval cemetery mentioned, the simple enclosure, which recalls the extra-urban character of early christian cemeteries, represents the most widespread model in England. The use and construction of cemeteries with ossuaries in towns ceased as early as the sixteenth century, and the term churchyard described the lawn enclosed by a low fence in which the presence of individual burial markers was commonly admitted, although this was not the rule<sup>8</sup>. In the middle of this space, the Vicar used to let the cattle graze, an image that was later to refer to a bucolic and then romantic vision of the cemetery.

The former model, however, the first to be established (the previous model was found from the twelfth century), is perhaps the best known. It takes the name of Charnier in France and

.....

5 Charles du Fresne, sieur du Cange, known simply as Du Cange, was a French historian, linguist and philologist of the seventeenth century to whom we owe the writing of the *Glossarium Ad Scriptores Mediae et Infimae Latinitatis*, an interpretative tool of the medieval Latin of fundamental importance.

6 For example, the term *aitre* was used to indicate the proper cemetery in France until the end of the Middle Ages. This was only later replaced with a term probably of popular origin, *charnier*, which changed from indicating the whole cemetery to describing a specific part of it. In England, on the other hand, the term used for the cemetery in the same period, which denounces its Latin origin, was preserved for so long (the term cemetery was introduced in the 18<sup>th</sup> century) that it is still used as a synonym for the modern cemetery: churchyard.

7 Inscriptions were not uncommonly separated from the burial site within the church because of the high demand for space. The undertaker's main job from medieval times to the nineteenth-century reformation was to lift the stones of the graves that hosted the remains once they had been consumed, carry the bones to the ossuary and arrange the space to receive new ones. Even if there had been a coincidence between an inscription and the burial, it would not have lasted longer than the time it took the body to rot.

8 From a religious point of view, we have so far referred to Christianity. This in the broadest sense dictated the general rules within which Catholicism, Calvinism or Protestantism generated their own variations from the architectural point of view. While Catholicism and Calvinism long supported the concept of anonymous, collective burial and preferred church burial, Protestantism allowed individual burial and preferred burial within the cemetery. According to Aries, at the end of the 16<sup>th</sup> century, this preference established the birth of the public cemetery, which was not secular, even in Catholic areas, because of the strong pressure from the Protestants.



Camposanto in Italy and the most well-known examples include the Cimetière des Saints-Innocents and the Cemetery of Pisa<sup>9</sup> (Fig. 2).



Fig.2. The Camposanto of Pisa. Source available at: [https://it.wikipedia.org/wiki/Camposanto\\_monumentale](https://it.wikipedia.org/wiki/Camposanto_monumentale)

As already mentioned, the word cemetery was loaded with further meanings which, although they had no relationship with the space and the architecture of the cemetery itself, played a great role until the seventeenth century in maintaining those characteristics of indifference and promiscuity between the alive and the deceased against which the Enlightenment fought in the eighteenth century. The cemetery was, in fact, considered a place of asylum, *asilum circum ecclesiam* (Aries, 1977; Bertolaccini, 2004). This definition transformed it into a square, a forum, but also a market place and a fair ground and, in extreme circumstances, a dwelling. When inside the town, it had a social function for the community that disregarded its funerary nature, so much so that cemeteries that did not host deceased but only provided shelter and refuge for the living were created.

So intense was this sense of community that, quoting the words of a medieval historian specialised in funerary law who describes the cemetery of that period as “*the noisiest, busiest, most turbulent, most trade-intensive place in the rural or urban settlement*” (Aries, 1977:73), the historian Aries wonders whether it was the monastery or rather the cemetery that was the model for the rectangular plazas surrounded by loggias and shops found in some examples from Spain and Paris (Aries, 1977:81). Likewise, it is no mere coincidence that, after the closure of the cemetery of the Innocents, a covered market and a square were built on the space of the cemetery. The space of the ancient cemetery lost its funeral

.....  
 9 It is interesting to note how, even though they belonged to the same type of cemetery, in France from the eighteenth century onwards people demanded the closing of the former and at the same time referred to the latter as a model for the construction of new cemeteries (de Quincy, 1788). The monumental nature of the Pisan building is probably the cemeterial feature, absent in the French one, that they wanted to replicate. However, such a reference presupposes that the difference in scale that had generated two cemeteries only apparently so dissimilar was not fully understood: the Pisan community was numerically smaller than the Parisian one and consequently needed limited spaces, that were architecturally more controllable and framed in the atrium model. It does not seem strange that, despite the reference to the Pisan model, it was finally a garden-cemetery, the *Peré Lachaise*, that was built.

function and preserved its function as a collective space. However, the representations of this same cemetery, so famous as to be given the nickname “*flesh-eater*” (Aries, 1977:419), were certainly representative of a reality and a promiscuity which, at the end of the seventeenth century, had become unacceptable. This feeling became the incentive to rethink the medieval cemeteries that had been preserved up until then. However, that same cemetery’s social function, which had led to promiscuity, was not lost with the changes between the eighteenth and nineteenth centuries, but was modified, changing its features to better reflect the new sensitivity and the new socio-cultural aspects.

XVIII century, beginning of the cemetery reform: hygienism, functionalism and the secularization of space

Already towards the end of the seventeenth century, due to the great epidemics of plague, doctors were raising the issue of burials within the city and the intermingling of the space occupied by the living and the dead. This represents a first important sign of change in the relationship with the corpse that was to lead to the first cemetery reforms in the eighteenth century. The revival of the perception of the corpse as something impure, already perceived in pre-Christian times, was to be the point on which the Enlightenment redesigned its cemeteries. It was a reaction to the city’s image of the period, “*macabre Piranesian scenarios in which luxury and misery, magnificence and extreme ruin coexist*” (Bertolaccini, 2004:11). The cemetery reforms of this century were strongly opposed not so much by the clergy, as one might imagine, who were actually prominent supporters, as by the people, who still had their pagan beliefs, superstitions and practices. Throughout the first half of the century there were writings and memoirs by doctors, priests, and more, on the unhealthy effects, mephitic odours, strange noises and sudden deaths due to the insalubrity of cemeteries and churches, but it was not until the second half of the century that these led to the establishment of new functional programs. The goal was to streamline burials and to set up programs that respected hygiene and contributed to the dignity of the deceased.

In France, for example, in 1763, the first parliamentary decree of Paris banned burial *apud ecclesiam* and expelled cemeteries from the city. It prescribed the construction of cemeteries outside the city walls for the clergy, the nobles and the common people, and allowed individual burial only after the payment of an expensive tax, reducing the clergy’s role to that of a simple supervisory authority<sup>10</sup>. It was probably an excessively innovative decree for the historical time, and was followed by a subsequent one in 1765 which, moderating the initial stances, accepted the burials of the clergy in churches once more. It was only in 1775 when, with a Pastoral Charter, the archbishop of Toulouse prohibited burials inside his cathedral not only for laymen but also to the clergy (followed in 1776 by a Declaration royale), that there was a first decline in the church’s supremacy over cemetery space. However, it was the French Revolution that effectively secularised the cemetery and, between the end of the eighteenth century and the beginning of the nineteenth century, rethought the whole funeral ritual.

In Spain, the reform of Charles III, tried to break the previous order in 1787, failing due to the fact that opposition in this country was stronger than elsewhere and, even in the mid-

.....

<sup>10</sup> Laura Bertolaccini remarks how this decree is so close to the secular cemetery that it can be considered the precursor of the Saint Cloud edict (Bertolaccini, 2004).

nineteenth century, there were still few new cemeteries, despite a long series of ordinances. In Italy, from a legislative point of view, it is worth mentioning the Duke of Modena who, at the end of the eighteenth century, ordered the construction of a new cemetery outside the city walls. From the architectural point of view, however, we cannot forget the treatise by Francesco Milizia (1781), *Principi di architettura civile*<sup>11</sup>, which includes the cemetery among “*Buildings for health and public needs*” and the work of Ferdinando Fuga, architect of the Santa Maria del Popolo cemetery, well-known as the three hundred and sixty-six graves, active from 1762 to 1890. Expression of a long study in the cemetery field<sup>12</sup>, in Italy this is the physical translation of the principles of the Enlightenment: outside the city walls and located on a northern hill (with respect to hygiene principles), it has a monumental atrium layout with loggias and arcades (in continuity with the type in use in the area) at the centre of which the space of the mass graves is streamlined by the presence of 366 pits corresponding to 366 mass graves, one for each day of the year (functional principles), “*a secular and rational architecture that, for many years thereafter, will be taken as an example*” (Bertolaccini, 2004:27).

In England, as already mentioned, the urban cemetery had been previously abandoned, and the suburban cemetery had been exported to the American colonies. This type of cemetery, strongly related to the natural environment and the life cycle, had meanings related to the return to Mother Earth, gradually turning into the elegiac setting dear to the poets and writers of the nineteenth century.

A further aspect that must be highlighted is that, during this period, the streamlining of burials also involved the study of the space required by the corpse. With the advent of Christianity, in fact, the custom of cremating bodies, much used in previous eras, was abandoned and only the practice of burial was accepted<sup>13</sup>. In the eighteenth century, alongside the cemetery’s secularization, there was a return to the analysis of the space dedicated to human remains. Revolutionary and Napoleonic France was undoubtedly the place of the liveliest debate, where the projects (never realized) of new large cemeteries replaced the space of the church with monumental crematoriums or buildings aimed at the process of vitrification of the bones.

Although the rationalization of the “house of the dead” within the “city of the dead” was to take on different spatial features from these proposals in the nineteenth-century cemetery, the search for the minimum unitary space continued. In underlining the ever-present specular relationship between the city of the living and the city of the dead, Michel Ragon, relates Le Courbousier’s *unité d’habitation* and vertical garden-city to the work of some architects who proposed vertical cemeteries made of urns because “*...On a surface of ten square metres there are only four dead people, while two hundred funerary urns could be placed in the same space...*” (Ragon, 1986: 275-276 ).

### *The decree of 23 Pratile of the year XII and the birth of the modern cemetery*

The edict of Saint Cloud is the act that ratified the definitive abandonment of medieval cemeteries and established the basis for cemetery space management that is still current

.....

11 Principles of civil architecture.

12 Ferdinando Fuga had already previously dealt with the field of cemeteries.

13 Like every other change related to cemeteries, the practice of cremation was gradually abandoned and, only in 785 A.D., did Charlemagne definitively prohibit this practice with the *Capitulare Paderbrunnense*.

today<sup>14</sup>. Considered the founding event of the “*culte des morts*” (Aries, 1977: 608) in modern western culture, it is the act through which, in France and then in Italy<sup>15</sup>, the criteria for planning new cemeteries were definitively established. The Edict, divided into five titles for a total of 28 articles, contains indications both on funeral ceremonies and on the technical discipline concerning cemetery construction, dealing with the whole problem of burials, from hygiene issues to the dignity of the dead.

The edict represents both the hygiene principles of the Enlightenment, which had already analysed the problem of burials in the eighteenth century, and new nineteenth-century feelings related to the singularity of the individual and to mourning. While on the one hand, in line with the former, the edict prescribed the establishment of cemeteries outside the walls, about 35/40 m away from the town<sup>16</sup>, preferably to the north and on a high site<sup>17</sup>, on the other hand it abolished the practice of burial in mass graves. The order was given to create a single grave for each body, to place them side by side<sup>18</sup>, and admitted the right<sup>19</sup>, equal for all, to have a sign such as a tombstone or other symbol on the place where the relative or friend was buried<sup>20</sup>. The latter article, as stated, does not seem to refer to the right of the deceased to have a funerary inscription, a practice typically prescribed for famous men or clergy, so much as to the right of the living to be able to go to the specific place where the deceased was laid to rest awaiting eternity. It represented the cemetery’s new social meaning: no longer a square, a forum or a market, but a place where people gathered to weep, pray and meditate, a place where they could meet their loved ones again. It was during this period that the practice of visiting cemeteries was born<sup>21</sup>. An expression also of the new bourgeois society, the edict introduced the concept of perpetual concession. This was bound to the typical view of the period, according to which anything could be bought and become someone’s property, even a piece of land within a cemetery<sup>22</sup> (until then a holy place belonging to the church or the state) as long as taxes were paid to the various competent authorities. A mausoleum or some other form of private tomb could then be created on the land purchased<sup>23</sup>. The new Romantic and bourgeois rules, much more than those borrowed from the Enlightenment, changed the cemetery’s architecture. The necessary rethinking of the model for burials, the proliferation of identifying signs, which evolved from simple tombstones into obelisks, statues and mausoleums, visiting the cemetery, these are the aspects that defined what some scholars call the “*bourgeois cemetery*” (AA. VV., 2000), which does not greatly differ from the image of the cemetery that we still have today.

.....

14 This represents the first major regulatory framework of new vision in the West. Moreover, it is worth remembering that, although the Edict was valid only in France and partly in Italy, the issue relating to burials was felt all over the West and there was a great diffusion of ideas, projects and, above all, legislation among the different nations.

15 The edict was also extended to the Italian territories of French domination in 1806.

16 Artt. 1 and 2.

17 Art. 3.

18 Artt. 4 and 5.

19 Not derogable is the term used: *Il n’est point dérogé*.

20 Art. 12.

21 Aries places the establishment of this practice in England, where the elegiac cemetery landscape had entered literary production in the mid-eighteenth century as a site of memory and mourning and communication of regret.

22 Artt. 10 and 11.

23 Alternatively, continuing the earlier practice, every five years the bodies were exhumed and transported to an ossuary.

### 3.3 Cemetery typological interpretation

- **Cemeteries and urban morphology**

Modern cemeteries were born in 1804 with the Saint-Cloud edict, through which Napoleon Bonaparte regulated the construction of cemeteries and definitely demanded they be built far away from urban areas. If it is indeed true that the edict represents a milestone in the Western history of the cult of the dead, its innovative content is not represented by the ban of cemeteries from cities, perhaps the most well-known of all the articles in the edict, but rather by the adaptation of burial practices to the new modern society, an act that involved a rethinking of architectural models that had been practice in previous centuries.

From a topographical point of view, in fact, the area dedicated to the dead underwent changes in which the eschatological or cult events intertwined with those related to urban morphological development, alternately distancing or re-enclosing the cemetery within the urban perimeter over the centuries.

The relationship between cemeteries and city transformations requires a *phenomenological-structural analysis* (Dalla Negra, 2014) which can only be conducted on a case-to-case basis; however, it is possible to outline a general framework of this relationship which allows us to understand, on a lower and more specific scale, the transformations that occurred in individual cities. As a special product of human construction, cemetery architecture played a role within the mutations of urban centres, being part of that “*silent and anonymous history*” (Dalla Negra & Zuppiroli, 2012) that involved and involves the transformations of our cities. The specialization of which it has been invested has conferred on it particular features that have qualified it, in different historical periods, as *polar*, *antipolar* or *nodal* (Caniggia & Maffei, 2017) architecture within the *connecting tissue* (Dalla Negra, 2014) of the cities. It seems nowadays improbable to assign cemetery architecture any other value than that of *punctual antipolarity*, but it must be considered that the main question can be traced back to the difference, accepting a separation made by the historian Aries, between the attitude *de morte* and that *de mortuis*, that is the attitude towards death and towards the dead. If the former, quoting Aries again “... *has survived evolutionary progress for about two millennia ...*” (Aries, 1977:32; 675-712)<sup>24</sup>, the second, more willing to change, has led to transformations that have also involved the use and perception of cemetery space.

In ancient times, the dead corpse was considered as impure and toxic and was consequently expelled from the collective space (the methods used to treat corpses were obviously related to the uses and customs of different civilizations<sup>25</sup>). Even in Roman times, the dead were buried outside the city walls along the main roads<sup>26</sup> or in private land adjacent to them. Their location, then as now, was outside the city, in other words, graves and tombs represented an *antipolarity* that set the city limits. It was the rise of Christianity during the Roman Empire that changed the perception of the dead body. The Christian eschatology of belief in the

.....

24 It should also be noted that Aries places the change in this attitude towards death, no longer “domesticated”, reversing its image, with society’s refusal of mourning and the transfer of the sick and dying to hospitals after the imposition of medicine, in the twentieth century. Although, he does not recognize the same distinction in the perception of death, there is no difference in the image conveyed by Ragon and his “thanatocrats” (Ragon, 1986).

25 For an overview of customs and traditions in both ancient and modern times (Ragon, 1986; Aloï, 1959).

26 To mention just one case, remember the burial ground found along the Appian roads.

Resurrection of the body in the African Roman provinces was associated with the veneration of the ancient Martyrs and their tombs. The latter was a pagan legacy stemming from the conciliation between the new imperial religion, Christianity, and the traditional one. The fear of grave-robbing, which was originally related to the fear of the looting of sarcophagi, turned into the anxiety of compromising one's resurrection on Judgment Day by the lack of a body. In addition to this, there was an absolute certainty of eternal bliss for saints and martyrs<sup>27</sup>, which transformed relics into sacred artefacts around which all fear had to be lost: in the Christian world, the practice of burial *ad sanctos*, burial near the tombs of martyrs, who offered protection to the body and the spirit of the dead, appeared. In 563 A.D. the Braga Council still forbade the presence of *intra-muros* tombs, so the martyrs' graves, which dated back further, were placed in sacred and external places, in the same site as the ancient pagan tombs, burial grounds and necropolis. Initially, some *martyriae* or *memoriae* were built on them, and later, with the increasing notoriety of the place, basilicas were established in place of these chapels (or next to them) to welcome visiting pilgrims. The appeal of common burials near these cemeterial basilicas soon grew, so, in the first instance, the pagan funerary areas coincided with the Christian cemeteries *extra muros* placed under the saints' protection.

As the cemetery basilicas were attended by secular or religious communities, in most cases, an Abbey ended up settling there. The cemetery basilicas, which at the beginning of the Middle Ages represented one of the two centres of Christian life<sup>28</sup>, became a *node* of such importance that initially they mitigated, and later eliminated, the repulsion for the dead, and became the centres of the new urban expansions, assuming a *polar character*. It is clear that, with the consolidation of these nuclei and the subsequent enlargements, these basilicas which were *extra-muros* for Roman society, later found themselves *intra-muros*. So, the cemeteries related to them became a *nodal architecture* within the city<sup>29</sup>.

Another effect of this transformation was the disappearance of the "competition" between the two poles of the medieval city, the cemetery basilicas and the cathedral churches<sup>30</sup> because, once the dead were placed within the walls, albeit in peripheral areas, it became easy to claim the right to keep the relics within the churches themselves and thus attract not only pilgrims but also tombs. The church with its enclosure became a burial place from the seventh century. Once inside the new urban area, the estrangement between cemetery space and social life was removed, and the autonomy of cemeteries from the church was also lost.

Another phenomenon of great relevance took place during the late Middle Ages. This was the replacement of burial *ad sanctos* with that *apud ecclesiam*, i.e., from near the saint to near the church. This seems to be a transition with little or no value. However, replacing the saint's protection with that of the church's meant that all churches, existing or new, could perform the cemetery function (not to be confused with the funerary function, already rightfully performed by any ecclesiastical place). From the sixth century A.D. onwards, every council fully emphasized how, in reality, the church space had to be considered quite

.....

27 Tertulliano, De resurrectione carnis, 43.

28 The other one was the Cathedral.

29 Just think of the medieval Parisian cemeteries, such as Saint Innocents or Saint Sulpice, which operated until the eighteenth century and which, at that time, were located at different points within the city.

30 The roots of this rivalry lay in the decline in prestige and visitors to the cathedrals to the benefit of the cemetery basilicas which, unlike the former, could host the saints' relics.

distinct from its enclosure within which, even leaning against the walls, the practice of the cemetery function was allowed. Councils, such as that of Rouen (1581) and Reims (1683), also specified the only categories for which exceptions were permitted. Considering the temporal extension, over a period of about 1000 years, Aries (1977) rightly points out that the systematic recurrence of the precepts concerning the church burial ban indicated a well-established contrary practice. Specifically, instead of abolishing the practice, the canonical prohibitions ended up creating a hierarchy in burials subordinated not to honour (the will of canon law) but to the payment of tax. Therefore, the cemetery, which had already lost its autonomy, also lost part of its value as a burial space, becoming the poorer classes' burial space, being the place farthest from the spiritual centre (obviously the main altar for Christian eschatology). Not only did the cemetery lose its topographical independence (previously a church was installed where a cemetery stood and not vice versa) but it had to share, almost losing, the function for which it had been created.

At the end of the seventeenth century, the space occupied by the dead was still inexorably mixed up with the space occupied by the living, but in the eighteenth century the indifference, generated until then by this situation, turned again towards the recovery of the sense of repulsion and reopened the debate on burials. The cemetery, which regained its spatial value, was again perceived as an architecture to be banned from cities. This culminated in the nineteenth century with the edict of Saint Cloud. The edict prescribed, in France and in Italy, the removal of the cemetery from the urban perimeter restoring the quality of *punctual antipolarity* that still remains today.

- ***Determining the matrices of specialization: interpreting the typological series***

The methodological reference for the study and analysis of cemetery typology is, as previously mentioned, that of the school of Saverio Muratori, whose effective and immediate synthesis of the most important achievements has been exposed by Riccardo Dalla Negra (2017). This includes the redefinition of the *building typology* that moves through the concept of *type* as an *a priori synthesis*<sup>31</sup>, the identification of *type* as a phenomenon no longer abstract and static but constantly changing, and the concept of *typological process*. We also owe the Muratorian school the overcoming of the definition of major and minor construction in favour of basic and specialized building.

Cemeteries fall into the latter group. Gian Luigi and Mattia Maffei, continuing the studies started by Caniggia for the basic building, identify some aspects, typical of the specialized building, that can help us understand a development based on the dialectic between two processes, one linked to the *spontaneous consciousness*, already typical of the basic building, and the other linked to the *process of intentions*.

*Cultural area - territorial delimitation of typological analysis*

A first important aspect to assess when approaching the typological analysis of cemeteries is that, contrary to the basic building, more related to the site of settlement, the specialized building, like the cemetery, is a synthesis of the experiences that are defined in geographical areas other than that in which it was produced (Maffei & Maffei, 2011).

.....  
31 To this end, Benedetti (1988) remarked how Muratori's ideas had allowed the concept of typology to emerge from "a classificatory and abstract use".

Its features tend to be replicated regardless of territorial boundaries. Therefore, it becomes important to understand the framework within which to conduct one's reflections. In this sense, Caniggia and Maffei (1979) explicitly refer to the concept of cultural area. As far as cemetery organisms are concerned, according to a distinction already made and agreed upon by historians and/or anthropologists, the cultural background within which the analysis is substantiated is delimited by the attitude towards death of different cultures. In this particular case, the limit within which the analysis is carried out is that of the Western attitude towards death.

### *Process of intentions and cemeteries*

Regarding cemetery type, it must be said, the process related to the authors' intentions seems to play a marginal role from the architectural point of view. The intentions (Christian, functional, secular, patriotic...) with which each author has imprinted his project have inevitably had to deal with what the community recognized as the idea of the cemetery. A "new" cemetery was built only where the dominating *type* was adapted to the author's own intentions without making it unrecognizable to the community. It is no mere coincidence, therefore, that the great cemeterial architectures designed by Ledoux or Boullée, such as the system conceived for the city of Chaux or Newton's cenotaph (Fig. 3), which use elementary forms, such as pyramids or spheres, to recall patriotic ideals of equality and purity or to celebrate the greatness of particular figures, remained simple stylistic exercises<sup>32</sup>.

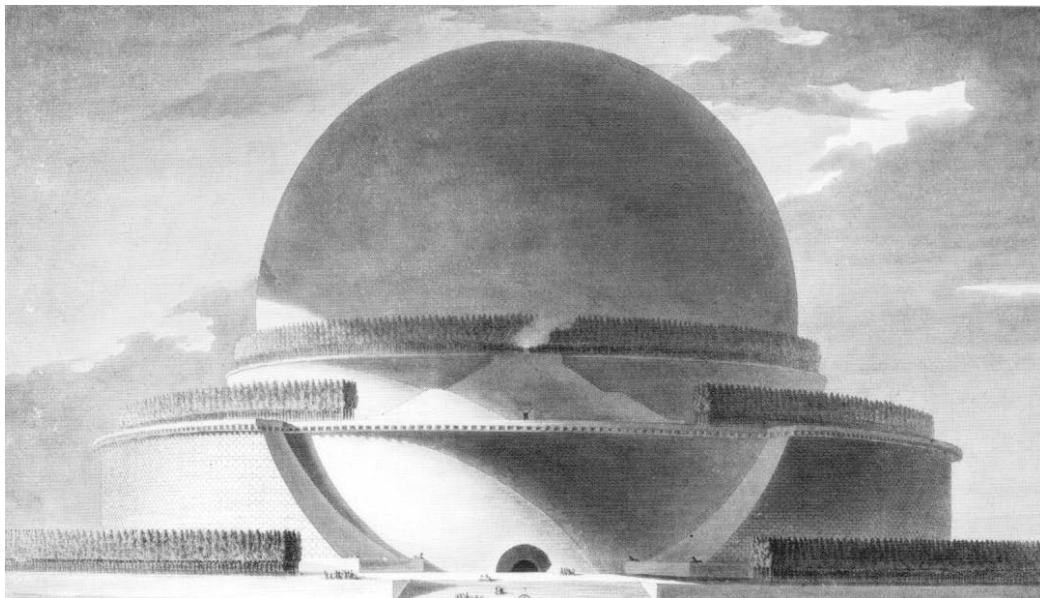

Fig.3. E. L. Boullée, Project for an Isaac-Newton-Memorial. View by night (Toman, 2000).

These are fundamental examples in the debate on cemetery architecture in eighteenth-century France, just as the treatise of Milizia and the Fuga's work were in Italy. However, they never became a built object. Similarly, it is not surprising that great projects that pushed functional needs to the maximum consequences, minimizing the cemetery's built footprint, from the

.....  
<sup>32</sup> There are several essays on the work of these two architects, in general (Kaufmann, Grandi, Teysot, 1976) or about their cemetery projects within the historical framework of the period (Bertolaccini, 2004).



proposals for the vitrification of corpses to the most recent tower-cemeteries (Fig. 4), although the latter have had little experimentation (Fig. 5), have not been exempt from the same fate.



Fig.4. Project for the San Michele Extra vertical cemetery in Verona. The project presented in 2014 was to become the first European vertical cemetery project. After two years of discussion and controversy, it was finally abandoned in 2016. Source available at: [www.veronasera.it](http://www.veronasera.it)



Fig.5. Memorial Necropole Ecumenical - Cemetery of Santos, Brazil. Example of Vertical Cemetery. Source available at: [www.rainews.it](http://www.rainews.it)

The lack of recognition by the community, the real user as well as client of the cemetery, of its cultural references (in the architectural sense) in the projects, precluded their application, despite the fact that these had been carriers of the great ideals of the time.

A contrary case is represented by the project for the 366 Fosse cemetery of Ferdinando Fuga for Naples (Fig. 6). While representing a significant innovation on a functional level for

cemeteries, it does not deny, from a formal point of view, the typical canons of the cemetery, finding application at the limits of the city. This is a large burial enclosure, built to the north, in an elevated position, within which 366 numbered tombstones identify the opening on the ground of each of the 366 pits, one for each day of the year, where the poor were buried. At the centre of the courtyard there is a manhole for the collection and drainage of rainwater.

In 1762, the architect Fuga prepared a system that, while owing much, from an architectural point of view, to cemetery traditions (large, high fences within which to place the mass graves), was the bearer of all the Enlightenment and hygiene principles that people tried to apply throughout Europe.

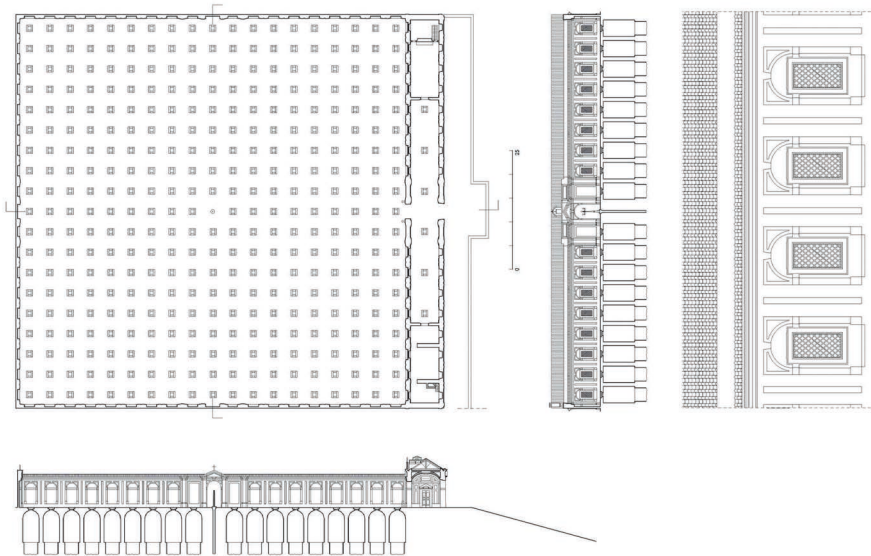

Fig.6. Plan, Sections and Standard elevation of the 366 Pits Cemetery. Source available at: [www.paologiordanoarchitetti.com](http://www.paologiordanoarchitetti.com)

Aldo Rossi, in designing and building the extension for the San Cataldo cemetery in Modena between 1971 and 1984, conceived a building which, while having modern forms, reinterprets the local cemetery enclosures with long porticoed wings of columbaria that define the perimeter (Figs. 7-8).

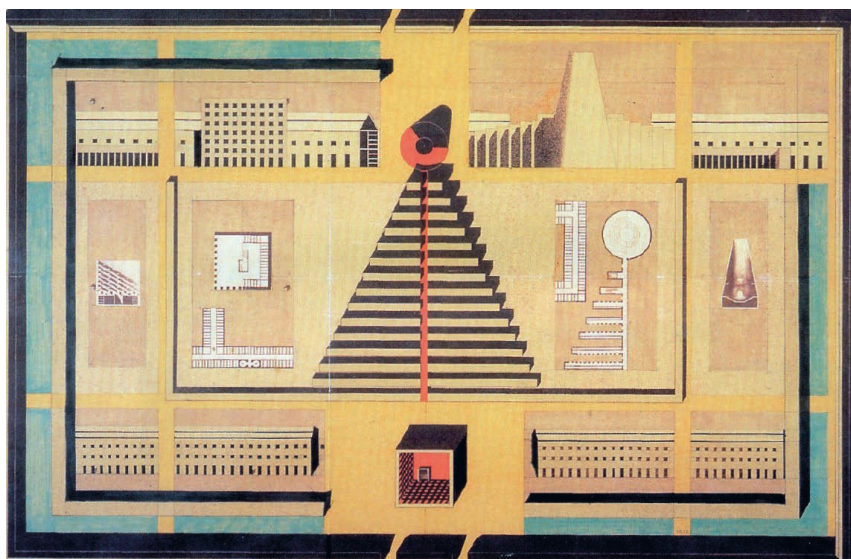

Fig.7. San Cataldo cemetery project by Aldo Rossi. Source available at: <https://www.jerusalem-lospazioltre.it/cimiteri-nella-citta-citta>



Fig.8. Photo of Aldo Rossi cemetery. Despite the new " shapes " the cemetery respects the historical characteristics of the area.  
Source available at: <https://www.domusweb.it/it/architettura/2002/09/30/aldo-rossi-e-il-cimitero-di-modena.html>

Specialization matrices and main typological series of the cemetery type

The western cemetery was born as a holy space, not necessarily enclosed, surrounding a *martyrium*, a funerary chapel built near the saint's grave and dedicated to his veneration. The first specialization of this space, probably related to the birth of the cemetery abbeys, or more generally to a structuring of the cemetery space which has no real hierarchy until then, takes on a configuration called the *atrium*. This seems to be a legacy of the *Roman domus atrium* and indicated a space enclosed by walls, with porticoes and loggias surrounding mass graves. A peculiar feature of this architecture was the presence, in general, of large lofts, open or closed, above the galleries, where bones exhumed from the ground were collected<sup>33</sup>. This specialization, which would remain unchanged for a long time, was based on matrices of an architectural nature. The name that designated this space from the Middle Ages, as already mentioned, recalled a precise constructive archetype, the *atrium*, without necessarily deriving directly from it<sup>34</sup>.

From the twelfth century onwards, a new series was born, flanking the existing one, with its own coherent processual evolution. The original *matrix* underlying the *typological process* was modified. If the first one was of architectural nature, this one was connected to the territorial structures, the typical matrix of specialized buildings that host functions that take place outdoors. In particular, it is a matrix that culturally refers to a typically pre-Christian concept that has never been totally lost, that of a return to nature and the life cycle. That is, the body's return to the natural scenario from which it derives and of which it becomes part again. This matrix generated the suburban cemetery that was then to spread widely throughout England: the fence, when present, was lowered and the space lost its architectural connotation, becoming a space where occasional headstones defined a landscape in which livestock was free to graze. From the twelfth century, therefore, two *typological series*, linked to the same specialization, but deriving from different matrices, the architectural matrix and the naturalistic matrix, coexisted. Geographically, these *series* were equally co-present until the Anglican schism. With the advent of Protestantism, we witnessed a further step in specialization, without architectural connotations, but more related to geographical aspects. While the first *series*, the one with an architectural matrix, interpreted the Catholic instances and represent the cemetery in those areas related to this devotion, the second was the spokesman of the Protestant instances and was more present in English-speaking areas, England and North America.

Between the end of the seventeenth century and the beginning of the nineteenth century, both *series* underwent further evolution. The succession of the Enlightenment first and then of Romanticism became the cultural premise of this evolution, while the French Revolution and the Napoleonic era represented the historical one. The new functional, hygienic, romantic, secular instances, the expression of individuality and the representation of the new emerging social classes (the middle class), which in little more than one hundred years

.....

33 The preservation of the remains within the sacred space, whatever it was, was what conveyed protection and ensured resurrection, which is why the bones, once exhumed, were always stored within the sacred enclosure.

34 Actually, the presence of the monks' abbeys next to the cemetery basilicas does not allow the clear definition of whether the matrix ad atrium is of direct derivation from the Roman domus or derived from a specialized line of another typological series, that of the convents.

were to revolutionize the historical, social and cultural context, penetrated the two series, leading to a rethinking of space. This was the birth of the modern idea of the cemetery<sup>35</sup>, the cemetery which, through spatial organization, its arrangement and decoration, was defined and seen as a mirror of society and of the new hierarchical organization of society, where the right to individuality and distinctiveness is ensured to everyone.

Starting from here, it was in the naturalistic matrix that what can be defined, according to the urban planning theory of the same period, as the garden-cemetery, while in the architectural matrix that cemetery called by Donghi (1935) as “a pianta architettonica”<sup>36</sup> and by Vovelle (1998) as “paysage lapidaire”, developed.

- *The garden cemetery*

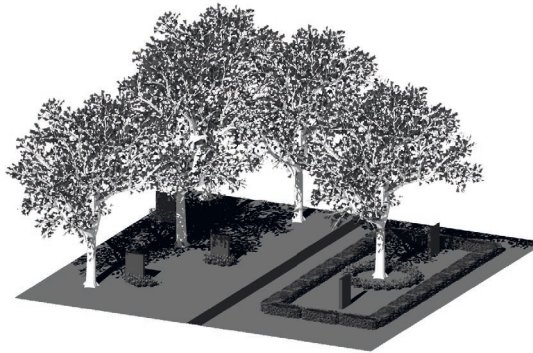

The garden-cemetery, full of the romantic meanings of the relationship with nature, abandoned the bucolic features of the previous cemetery and added funerary monuments, headstones and funeral chapels within a lush green space that encouraged the observer to pause, to express their mourning and to meditate.

It was in this derivation of the cemetery that the family chapel burial model initially developed. This evolution is connected to the need by the members of the middle-class to affirm and flaunt their social status. According to Laura Bertolaccini (2004), this model stems from the chapels at the sides of the churches, under which the corpses were placed, although we ought to remember that family chapels had already been present in the collective imagination for several centuries. They were a representation of a church on a reduced scale and, since the ninth century, had been built by landowners to perpetuate the memory of their dead, buried in *agris suis*. The famous examples of this *series* include Pere Laschase of Paris (1804). It was, in fact, in France that this *series* has the greatest development even in centres of lesser importance (Fig. 9).

From this, several *variants* have been defined. Park-cemeteries, such as Mount Auburn (Boston, 1831), which, by planning the space as if it were a large park ennobled by funerary monuments and tombs, create views and perspectives with the intention of provoking pathetic and elegiac feelings (Fig. 10).

.....  
 35 Bourgeois cemetery (AAVV, 2000), museified cemetery (Ragon, 1986), are just two of the various names attributed to it, none of which seems really representative of all of its characteristics, emphasizing only one of them.

36 Architectural design.



Fig.9. Historic cemetery of Avignon, an example of a garden cemetery in a medium-large city center.



Fig.10. Historical map of Mount Auburn. Source available at: <https://mountauburn.org/early-tours-through-the-garden-of-graves-mount-auburns-19th-century-guidebooks>

This variant has undergone a further development, between the late nineteenth and early twentieth century, leading, particularly in northern European countries, the establishment of forest-cemeteries, real forests where, at the bottom of the trees, you can find burials. In this case there is a further step in which the relationship with nature becomes priority compared to the need for a burial that can be daily visited<sup>37</sup>.

.....  
37 Indeed, this is the point at which, according to Aries (Aries,1977), the practice of nineteenth-century cemetery visiting began to disappear.

A further *variant* are the lawn cemeteries, very common in America but also in England: vast lawns in which the headstones orderly succeed one another and are distributed by a few cobblestone paths. This is a space that differs from the *type* used until the eighteenth century for the high monumental component produced in the lawn through the seriality of the tombstones that, generally similar in size, shape and material, mark and connote the space. It should not be surprising, therefore, that this *variant* of naturalistic matrix cemeteries is the one mostly used for the *series* of war cemeteries in the states that normally use such a matrix.

- *The architectural cemetery*

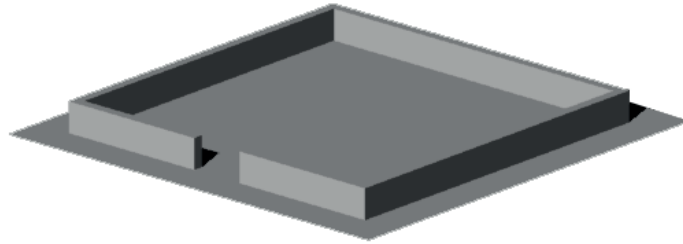

As far as the architectural cemetery is concerned, we are witnessing a rethinking not of the cemetery layout, the *atrium* layout, but a real rethinking of the burial patterns. In a parallel, often used for cemeteries, with the city of the living, it is not the “urban structure” to change but the “dwelling”. The atrium model remained, but the model of mass graves with ossuaries had to be rethought. The main element of this cemetery is the enclosure.

In dealing with the evolution of the funeral items, Ragon groups together in a brief overview the methods of body treatment in ancient burials, also identifying a geographical area across which they spread. He divides the methods into: *columbarium* and *aediculae* (Roman civilization), funeral towers (very common in Persian, Indian or indigenous civilizations of South America), and funeral pits (a common practice in many civilizations) (Ragon, 1986: 84-85). Based on this subdivision, it seems plausible to say that the mass grave used extensively until the nineteenth century in the West stemmed from the practice of the funerary pit. The new rules that banned the practice of body stacking in France and Italy made it necessary to rethink this model for burials. While cremation is no longer forbidden, it still tends to be rejected by the people<sup>38</sup>, and while common burial is an unbreakable right, ground burial or burial chapels cannot represent, as in the case of the very popular garden-cemetery, the reference model in the burial practice. In this case, the Roman model of the columbarium is reinterpreted.

This model, in the architectural cemetery, represents the transposition of the functionalism of mass graves within the new concept of grave dignity and individuality. The cleared loggias that previously hosted visitors and bones become loggias partially occupied by an overlay of individual graves. The model, therefore, provides the expedient to continue to bury vertically (a practice that the edict of Saint Cloud generally prohibited) without going against the right of the single grave and the personal headstone (Fig.11).

.....  
 38 Various authors (Aries, Ragon, Vovelle..) report statistics on cremation in different countries and although it is a rising phenomenon, like any practice concerning the cult of the dead, it takes a long time to become established and consolidated.



Fig.11. Cemetery of Scheggia, Marche region.

If the garden-cemetery defines its *variants* based on vegetation and the relationship with nature, it is the relationship with the church that defines the *variants* of the architectural cemetery. We can have buildings with funeral chapels, which are always aligned with another important element of the model, the main entrance. These have a single nave, rarely with a circular apse but often with pediments or monumental elements that distinguish them from the columbaria that branch off them. Alternatively, the nearby existence of a major church can generate a cemetery without a funeral chapel. In this case, the monumental entrance, which continues to be present, does not necessarily coincide with the entrance used for transporting coffins, but is linked to the shortest path connecting the church and cemetery. Therefore, in an effort not to lose the monumental axis which was created by the entrance and chapel in the previous variant, sometimes an *atrium* is added in place of the chapel. This is constructively more connected with the columbaria, with which it shares part of the structures.

A particular case is represented by cemeteries in reused structures. This is not a popular *variant*, but has found its justification in Italy in the concurrence between the cemetery reform and the abandonment of great architecture. In 1796, in fact, as a result of the Italian Campaign, religious orders were suppressed and the debate on the reuse of the structures that housed them was opened; among the proposals, in several cases we also find their arrangement as a cemetery. From a typological point of view, these buildings were not only already located outside the inhabited area, but they had initially shared the evolutionary matrix with the cemetery organism, and already possessed common characteristics. There were three large convents for which conversion to a cemetery seemed the most suitable solution: the Carthusian monastery of Bologna, that of Ferrara and that of Florence. Only the first two were actually converted (Guerzoni, 1992; Fabbri et al., 2018).

Lastly, just because the enclosure is the main element of this architectural type, simple enclosures can also be counted among the architectural cemeteries. In this case, they are enclosures without galleries, loggias or porticoes, where burial is permitted only in the



ground. This type of cemetery in Catholic and Christian culture seems to be more related to the albeit slight persistence of the ancient cemetery-church relationship that was interrupted during the eighteenth century, while it represents the basic type for Jewish cemeteries.

- *The war cemetery, a subsequent matrix of specialization*

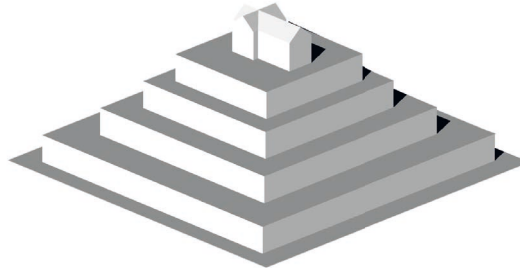

A last consideration on *typological series* can be made with respect to war cemeteries.

These were born after the First World War, when the number of dead on the battlefield and in the trenches had grown so much that it was necessary to provide an answer, particularly for public opinion, that gave a sense of dignity and tribute to the victims. In the peace treaties, a topic of no minor relevance was the establishment of cemeteries for the dead, whether they belonged to the defeated or the victorious country. Until then, the dead on the battlefield were abandoned and buried where they had fallen. Only famous men, military officers, generals or members of the highest social classes were brought back to their families and buried in cemeteries.

If we observe the layout of war cemeteries, it is easy to see how, regardless of geographical location, they generally follow the most common cemetery variants in the country of origin<sup>39</sup>. If we look at German cemeteries on Italian soil<sup>40</sup>, such as that of Cassino, we can appreciate how the debate in the homeland has been translated into a cemetery-garden in Italy. Conversely, Italian military cemeteries declare their architectural matrix even when built in different geographical contexts, such as the military memorial of Caporetto in Slovenia (Fig. 12). From this point of view, it would seem easy to trace the individual cemeteries, case by case, to the *typological series* of origin. However, if we look more closely, we can identify a matrix common to all war cemeteries, regardless of whether this is expressed in the form of a garden-cemetery or an architectural cemetery.

The monument is the archetype underlying all these cemeteries. Each of them is born as a cemetery that honours its own fallen, exalting its own nation at the same time. They are cemeteries which, contrary to those belonging to the previous *series*, are born already completed, without any possibility of growth. The burials accepted are those established at the outset and there is no provision for a relocation of the remains after a definite time to allow the accommodation of new corpses. There are no strict rules that characterise the development of the “city of the dead”, specifically because they are not thought of as places in the making but as photographs of a particular moment, a monument to the eternal

.....  
 39 Each nation, subject to agreements between states, is entitled to its own national military cemetery on foreign soil.

40 An updated work concerning the historical, artistic and architectural events of the German war cemeteries can be found in (Mulazzani, 2020).

memory of those who fell for their country. Their appearance may be an expression of the area's dominant type (i.e., a variant) at that particular time, but this acts as an ideal model for the representation of a nation through a macro-scale memorial.

For this reason, the war cemetery can be considered a further *typological series*, born from the First World War, with its own matrix, the monument, which identifies its own *variants* in the *types* of the other *series* reinterpreted, adapted to the cemetery's new function.



Fig.12. Cemetery of Caporetto, Slovenia.

## MAIN TYPOLOGICAL SERIES

### GARDEN CEMETERY

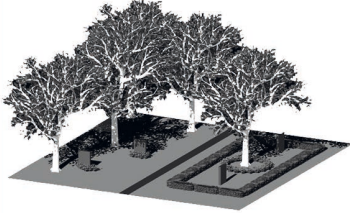

GARDEN VARIANTS

#### PARK CEMETERY



#### LAWN CEMETERY

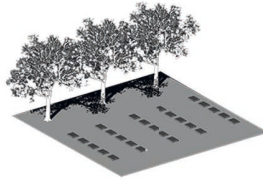

#### FOREST CEMETERY

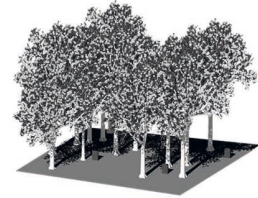

### ARCHITECTURAL CEMETERY

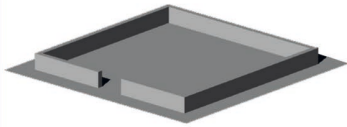

ARCHITECTURAL VARIANTS

#### CEMETERY WITH CHAPEL

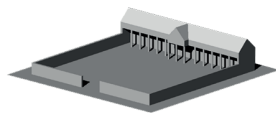

#### CEMETERY WITHOUT CHAPEL

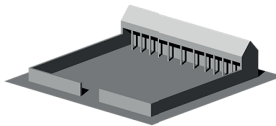

#### RE-USE OF URBAN VOID

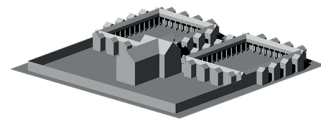

### WAR CEMETERY

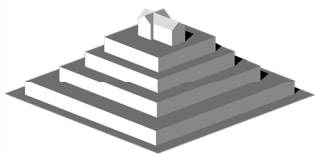

Fig.13. Outline of the different typological series and their variants.

### Standardisation process

From the beginning of the twentieth century, we see what is defined as the standardisation process, i.e., the tendency of *typological series* belonging to the same specialisation to incorporate the features of one series into another (Maffei & Maffei 2018:44). If the family tomb was initially one of the constituent elements of the *series* of the garden-cemetery, and the columbarium of the architectural, today both elements are used within the perimeter of every cemetery derivation to saturate the space (Figs. 14-15).



Fig.14. An indoor image of public cemetery structure in Colombario, Portugal. Cemiterio de Agramonte, Porto, Portugal.



Fig.15. On the right an outdoor image of public cemetery structure in Colombario, Portugal inside a garden-cemetery. Cemiterio de Agramonte, Porto, Portugal.

### Infill and growth processes of Italian cemeteries

The cemeterial function qualifies the buildings, like a city, as organisms in continuous development. They therefore grow constantly in relation to the contextual development of the population and the cities they serve. For this reason, the cemetery is often an architecture that has already been thought of as unfinished and which, by trying to take advantage of the rule of art, contains the elements to improve the continuous growth phenomenon in a structural key (Fig 16-17). The requirements of enlargement have led to a process that we can find in cities as well. A first growth was made possible through an *infill* of the enclosure, with extension due to the construction of wings, or the combination of family vaults next to each other. Alternatively, the cemetery has doubled in the area behind, in cases where enlargement has taken place over a considerable period of time from the last development phase, consolidating the extension of the on-ground burial space.

Once the space of the first enclosure has been filled, the enlargement followed the *successive doubling* law (Caniiggia & Maffei, 1979). Cemeteries extended more and more and the whole area doubled in volume. Depending on morphology and soil availability, the enlargement took place in the area below, or on one side. Also worth mention are the chartreuses of

Ferrara where, in the first half of the nineteenth century, the renovation project envisaged the creation of a new cloister next to the existing one, specifically designed for burying.



Fig.16. Budrione Cemetery (Modena crater area). Note the bricks set up for the future extension of the columbarium system.



Fig.17. Migliarina Cemetery (Modena crater area). The irons of the reinforced concrete beams are left out to be used in future enlargements.

## First infill process scheme

Through the porticoes extension

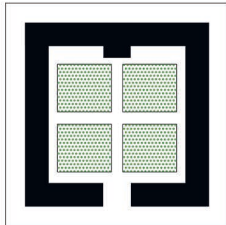

Cemetery of Motta (MO)

Through combination of family vaults next to each other

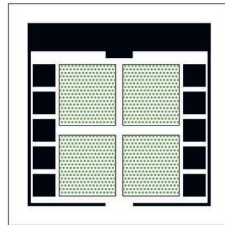

Cemetery of Vigarano Mainarda (MO)

doubling the building in the area behind

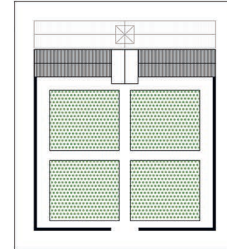

Cemetery of Finale Emilia (MO)

## Growing for successive doubling law

doubling on one side

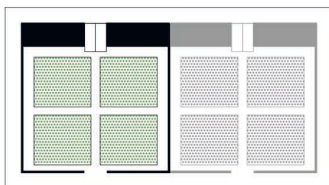

Cemetery of Concordia sulla Secchia (MO)

doubling in the area behind

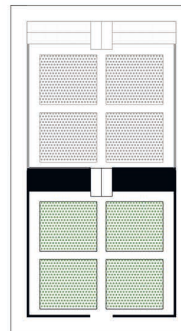

Cemetery of Bondeno (FE)

Fig.18. Infill process in cemetery type.

### 3.4 The features of cemeteries in the Emilia-Romagna earthquake crater

- **Morpho-typological features**

The cemeteries found in the crater in Emilia-Romagna are small and medium in size, belonging to the architectural matrix type. It is hard to see the coexistence in a single structure of several cemetery variants in areas alternately addressed only to one derivation or another. This is a feature of medium-large cemeteries, and the only cemeteries within the crater with a similar size and type are those of the Carthusian Monastery of Bologna and Ferrara which, being reused cemeteries, necessarily respect the architectural matrix.

This aspect should not, however, be interpreted as a lack of typical cemetery features with a naturalistic matrix. They are present, according to the *standardisation* principle, within these cemeteries through elements such as single or family tombs mixed with the columbaria structures.

In the crater we can recognise all the main methods of perimeter *infill process*. Many cemeteries have grown thorough to the addition of wings alone. This is the case of cemeteries like Concordia sulla Secchia, San Nicola in Carpi and small cemeteries like Piumazzo and Gargallo, in the Modena area.

The combined solution of wings and family tombs is also easy to identify. The use of family tombs, in particular, contrary to what happens in other areas of Italy where they are juxtaposed, recalling blocks of terraced houses (Figs. 19-20), is generally completely separate or, at most, connected through the continuation of the enclosure wall, as in the case of the cemetery of Vigarano Mainarda (Figs. 21).

It is also interesting to observe how, regardless of whether or not they are mutually connected to each other, when family tombs are used as *infill process* elements, they lose their singular features and respect the constructive steps and morphologies established in their development. This uniformity is again lost when they are isolated elements within burial fields (Fig. 22). In this area there is also just one example of saturation due to the doubling of the built volume, and that is the case of the cemetery of Finale Emilia, which has doubled the size of its columbaria in the area immediately behind the first wing over time.

When the *infill process* was completed, either by closure of the enclosure or by historicization of the status achieved, the cemeteries in the crater also grew by doubling the entire cemetery area. Depending on the location, this took place with settlement and according to the availability of the surrounding land.



Fig.19. Cemetery of Cogorno (GE) - North Italy. The cemetery is structured through family tombs in neo-gothic style placed one next to the other. Ph Arch. Luca Formigari



Fig.20. Cemetery of Scheggia (PG) - Centre Italy. The cemetery to overcome the problems of declivity uses the columbarium structure in the plane and an alternation of chapels and small ossuaries connected to each other for the steep parts.



Fig.21. Cemetery of Vigarano Mainarda (Ferrara crater area). Growth for family-tombs not connected.





Fig.22. Example of a family tomb included in the burial fields of the Bologna Chartreuse (Bologna crater area).

- **Main technological and constructive features**

Further observations on cemeteries in Emilia-Romagna can also be made from a constructive point of view. The huge time span of building development (from the second half of the nineteenth century – ongoing) coincides in the initial phases with a great transformation of the building process as a result of the introduction of new industrial materials and techniques: reinforced concrete and steel. A first analysis reveals how cemeteries were initially made of long wings, often in masonry, that were enlarged over time and showed more frequent use of reinforced concrete. Due to these progressive add-ons and juxtapositions, cemeteries are an extremely complicated *building type*, also because traditional technologies exist alongside new materials, like reinforced concrete and steel used in several structural parts.

The first point which this has affected is the scanning and organising of the columbaria. These are in fact built differently depending on the level of standardisation introduced with the new technologies. Columbaria were introduced into Italian cemeteries after the mid-nineteenth century in order to rationalise space. Nevertheless, it is still possible to find a cemetery, the Bondeno cemetery in the Ferrara crater area, where the “camposanto” (see section 3.1) model is still a strong reference point. In this case, there are no columbaria and the cemetery is an arcaded enclosure with headstones set in the floors.

Where the cemetery follows more traditional construction systems, with brick or stone elements and wooden beams or reinforced concrete, the columbaria are built with a tight pattern of orthogonal elements attached to the rear wall (Fig. 23).

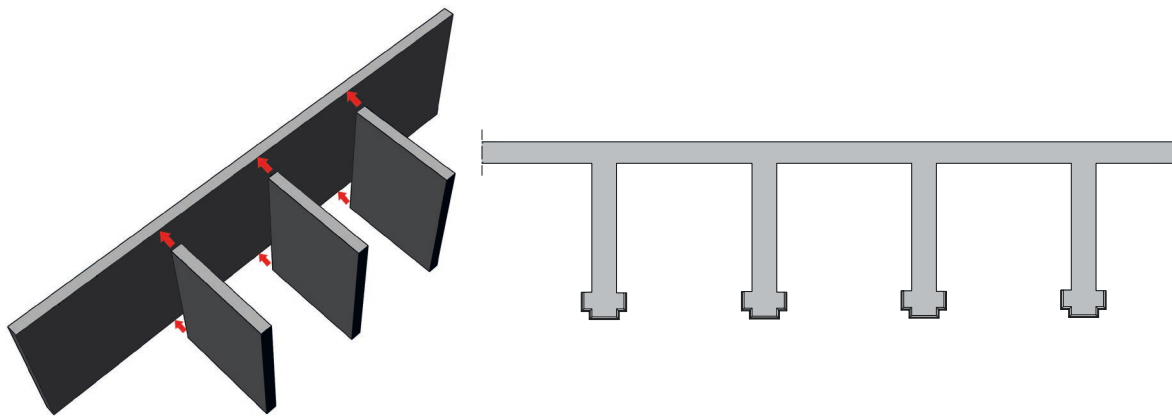

Fig.23. Structural scheme of historical cemeteries built entirely in masonry.

This system, with or without a front colonnade, creates the load-bearing structure within which the partition for coffins is inserted. In the Emilia crater area, the system consists mainly of brick walls and columns or pillars, with the occasional presence of columns in reinforced concrete or stone.

If, in this organising system, the spaces for coffins were initially made of brick or stone masonry, often recognisable by the curve of the horizontal closing elements (Figs. 24-25), later on, but also during the renovation processes, this micro-framework created with a single-ended masonry element, acting as a brace, is replaced by a prefabricated reinforced concrete element, a juxtaposed element inside the space (Figs. 26-27).

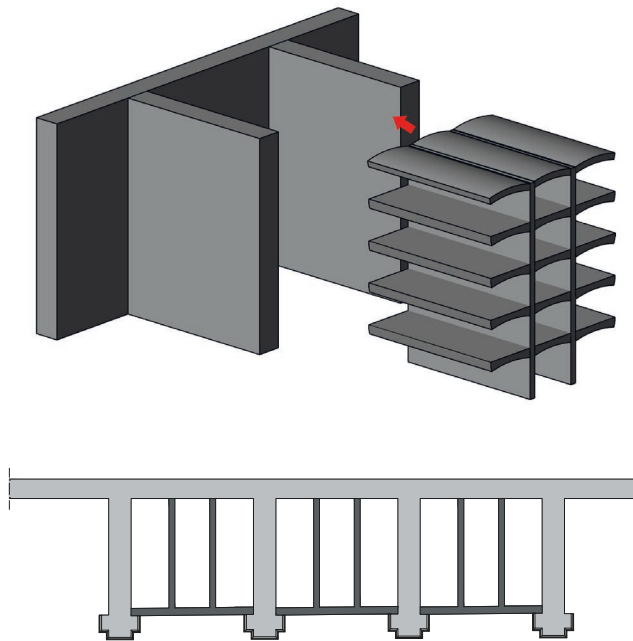

Fig.24. Structural scheme of historical cemeteries built entirely in masonry.



Fig.25. San Felice sul Panaro cemetery. (Modena crater area)

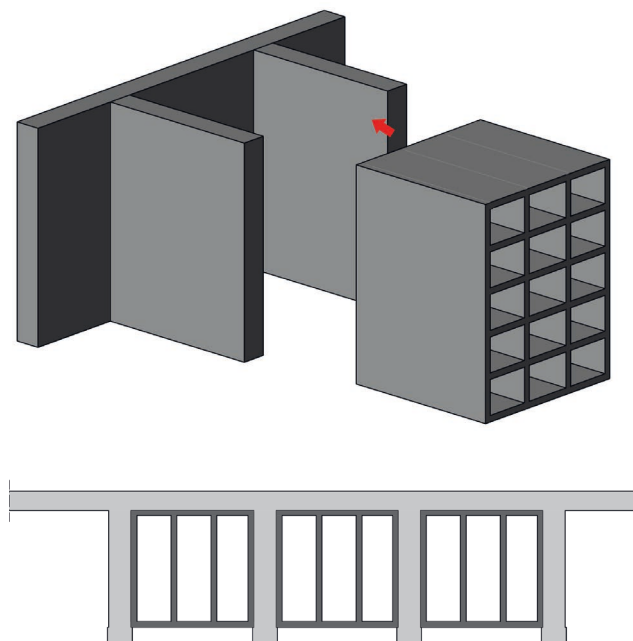

Fig.26. Structural scheme of historical cemeteries with prefabricated structure for niche.



Fig.27. Santa Croce cemetery at Carpi. (Modena crater area)

With the increasing standardisation of the building process, with the use of self-supporting prefabricated elements, the need to create a structure positioned orthogonally to the back wall of the columbarium was slowly neglected. A box, open at the front and in the length desired, running through the whole columbarium where required, was then built. The prefabricated structure for the coffins was placed inside it (Fig. 28). In this case, in the crater area, the external box is generally made of brick masonry, but there are also sporadic cases of concrete elements, as in the cemetery of Scortichino (in the Ferrara crater area) (Fig. 29).

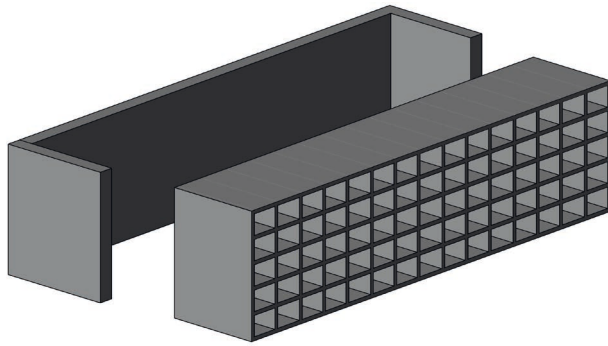

Fig.28. Distribution-structural scheme of the columbarium with external box in masonry and inner precast concrete elements.



Fig.29. Historic cemetery of Scortichino. (Ferrara crater area)

This structure tends to be potentially more vulnerable to earthquake than the previous one because the increased or reduced strength of the masonry, which can run for several meters without any cross wall, depends on the type and quality of the material. In the crater of the 2012 earthquake, for example, in cemeteries built entirely from brick, with occasional elements in stone or reinforced concrete, this construction technique does not seem to have suffered from the collapse of the rear wall. In the case of the 2016 earthquake in Central Italy on the other hand, where the construction materials and techniques are very different from those under investigation, ashlar masonry and more, the quake caused damage such as the collapse of the wall with the expulsion of the coffins (Fig. 30).



Fig.30. Image of the back wall collapse of the cemetery of Castelsantangelo sul Nera due to the absence of cross walls and poor construction quality. Source available at: <https://www.cronachemaceratesi.it/2016/11/04/castelsantangelo-nelle-frazioni-annientate-il-terreno-piu-basso-di-20-centimetri/882095/>

The second construction feature, on which the introduction of new technologies has had a significant impact, concerns horizontal structures. This interferes with another typical feature of the Emilia crater cemeteries, which represents one of the greatest vulnerabilities of these cemeteries: the construction of porticoed columbaria. Among the damaged cemeteries, porticoed structures represent about 98% of the elements. Only two cemeteries, in fact, feature columbaria without porticoes. This type of configuration, with sometimes long areas

without cross-walls and with occasional slender punctual supports, represents the greatest among the *intrinsic vulnerabilities* (Carocci, 2013) of Emilia's cemeteries. The arcades, positioned alongside very stiff elements like the columbaria, are, in fact, the areas that suffered most damage after the 2012 earthquake (Fig. 31).



Fig.31. Cemetery of Cortile (Modena crater area), the porch in front of the columbarium collapsed.

From the point of view of horizontal structures, porticoes are almost always covered by a non-structural brick vault. This is usually a barrel vault but still we find several examples of cross vaults as well. The arch then progressively became a depressed-arch, finally becoming a false flat ceiling. The latter is built mainly with SAP type floors, from large, reinforced hollow tiles, or with floors made with steel beams and bricks, if the floor is placed between the basement and the upper floor. To a lesser extent, it is possible to find simple floors made of hollow tiles and wooden elements, more rigid hollow-core concrete floors or porticoes without a horizontal structure (Fig. 32).

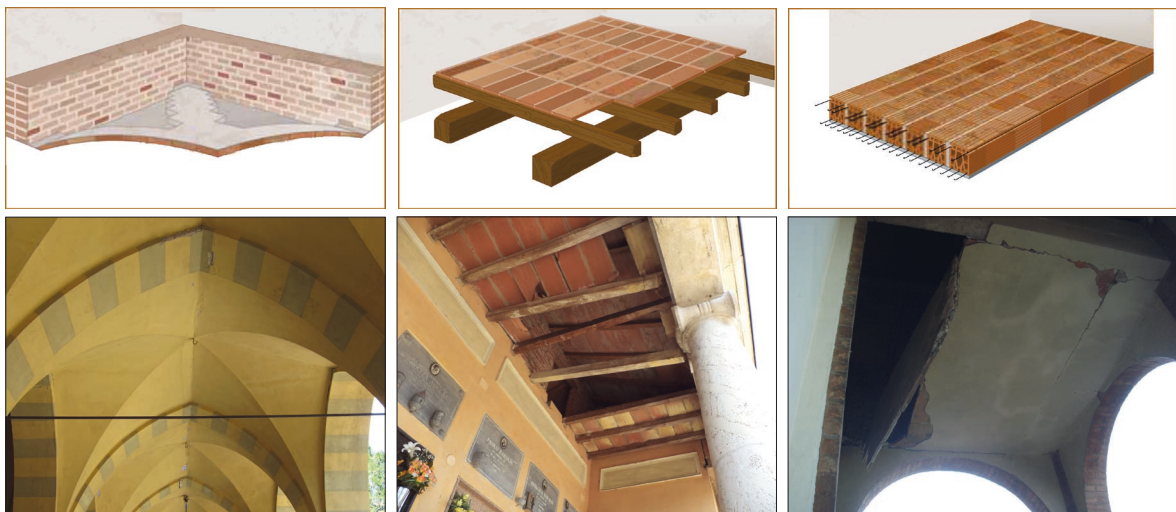

Fig.32. Some of the main constitutive materials of the horizontal layers

These horizontal structures, when present, are usually flexible, with the exception of hollow-core concrete floors, and often with weak connections to vertical structures, and are therefore more sensitive to seismic problems.

Lastly, we should consider the roofing structures. In the first phase they were usually made of wood in two different forms: the gable roof or the single pitch roof sloping outwards. It is interesting to note that the geographical distribution of the two solutions has revealed a tendency in the Ferrara, Reggio Emilia and Bologna areas, to apply the first solution while the second solution is preferred in the Modena area. They both include elements such as attics and/or decorations aimed at hiding the pitches and crowning the entablature above the portico. It should also be noted that, because construction history is closely related to the seismic history of a place and the analysis of the latter in the area under investigation reveals a past where there have rarely been severe earthquakes, with only a few significant events between the early nineteenth century and the first half of the twentieth century<sup>41</sup>, the presence of anti-seismic structures is limited.

The vaults are made primarily of timber, with a non-extensive use of ties (Fig. 33). Of the 27 cemeteries with vaulted structures, only 60% were fitted with this device. Even when it is present, its use is limited to the vaulted area and not extended to further critical elements, such as the roof thrusts (Fig. 34).



Fig.33. Concordia Sulla Secchia Cemetery (Modena crater area). Vaults without ties damaged by the earthquake.



Fig.34. Mirandola Cemetery. (Modena crater area). The vaults ties were ineffective as they were anchored to small walls on the side of the columbarium.

During an earthquake, the roof structures, generally of a thrusting or semi-thrusting nature, increase the thrust applied to the portico's punctual elements, causing them to overturn outwards. Regardless of the material, these have two possible aspects: the gable roof or the single pitch roof sloping outwards. It is interesting to note that the geographical distribution of the two solutions has revealed a tendency in the Ferrara, Reggio Emilia and Bologna areas to apply the first solution, while the second is preferred in the Modena area. In the

.....  
41 When the "new" cemeteries were built.

oldest systems, they are built with the traditional solution of wooden beams and hollow tiles, on which the roof tiles are placed.

However, mixed reinforced concrete and brick structures are also very common, often used in the growth of cemeteries and therefore compatible with the construction of a columbarium. This type of structure is also used for renovations. In this case, we have *transformation vulnerabilities* (Carocci, 2013). An emblematic episode is that of the cemetery of Concordia sulla Secchia, the cemetery most damaged by the 2012 earthquake. The cemetery was built in successive phases that shaped its closed perimeter and underwent heavy renovation interventions. The last of these, reported on the 2012 damage form, is a refurbishment of the roof structures with reinforced concrete beams and roof tiles. Before the 2012 earthquake there were three different horizontal structures:

- an older one, featuring a structure made of reinforced hollow tiles resting directly on the transversal walls (Fig. 35a)
- one with prefabricated beams with a longitudinal framework (Fig. 35b).
- one with prefabricated beams with a transversal thrusting frame (Fig. 35b).

The different construction techniques reacted differently to the earthquake: there was some local collapse in the original structures and significant collapse in the renovated parts, especially in the area where the thrusting solution had been installed (Fig. 35c).



Fig.35. Cemetery of Concordia sulla Secchia: a) roof structure in reinforced hollow core slabs leaning on transversal walls; b) roof structures with reinforced concrete beams and hollow core slabs with different frameworks; c) collapse of reinforced concrete structure at transversal frame (trusting effect).

A final aspect that characterises these constructions and represents a further *intrinsic vulnerability* of the *type* is the presence of attics and/or decorations aimed at hiding pitches and crowning the entablature above the portico or decorating the façades of churches, family tombs or crossing elements, such as the entrances to the cemeteries. These, being elements not necessarily fastened to the structures below, are not only vulnerable themselves, as they can collapse to the ground (Figs. 36-37), but also make the cemetery structures vulnerable, as they can damage them due to their own collapse (Figs. 38-39).



Fig.36. Cemetery of San Felice sul Panaro (Modena crater area). Collapse or damage of the projecting elements of monumental entrances



Fig.37. San Felice sul Panaro Cemetery. Collapse or damage of projecting elements of funeral chapels facades.



Fig.38. The Concordia sulla Secchia cemetery. Collapse of projecting elements inside the structures.



Fig.39. Cemetery of Vallalta (Modena crater area). Collapse of the projecting elements inside the family tombs.



### 3.5 From typological interpretation to the definition of the macro elements of the cemetery organism

- **Introduction and meaning of Macro-element**

The type analysis, divided into different components, such as those of a morpho-typological and constructive nature, is of considerable importance when it comes to understanding the structural behaviour of the building under examination. Historic buildings have basically, a poor box-like behaviour compared to modern ones. This is due both to the intertwining of constructive and seismic history and to the architectural evolution of each building, which has led to changes and alterations. Since their collapse is initially local and not global, it is important to identify the possible homogeneous areas within which such collapse can occur. These areas are referred to as macro-elements.

The term Macro-element was introduced by Doglioni as a result of his research. A Macro-element is: *“a constructively recognisable and completed part of the artifact, which can - but does not necessarily - coincide with an identifiable part also from an architectural and functional point of view”*. Macro-element means *“also the building element within which uniform behaviour, recognisable in the mechanisms as a result of seismic actions, is observable and fully describable”* (Doglioni et al., 1994: 71).

Accordingly, the above analyses have led to the breakdown of the cemetery organism into five different constituent elements, which allow both the architectural description of the cemetery building and the assessment of the damage suffered by it. Although the coincidence between the structural behaviour and the architectural aspect, in the Doglioni's definition, does not necessarily occur, the correspondence between the two is considered of essential importance by the real users of the scheduling tools on which this breakdown is used, the officials (architects, archaeologists and sometimes art historians) of the Ministry. If it is true that they are supported during the survey by expert technicians, the reliability of the data filled in on the damage survey forms is also closely linked to how these forms guide the surveyors in their judgments during operations (Presidenza del Consiglio dei Ministri, 2009:11). The correspondence between structural and architectural aspects makes it easier to interpret the data, even by those who rarely deal with the former but interpret the latter well.

The macro-elements identified for the cemetery system are outlined below. Two of them stem from the oldest permanent features, i.e., those features that have been maintained since the first codification of the cemetery in history, while the last three derive directly from the changes that occurred during the nineteenth century. The former are therefore the enclosure wall and funerary chapel macro-elements, while the latter are the crossing elements, the columbaria and the family tombs.

- **Enclosure wall macro-element**

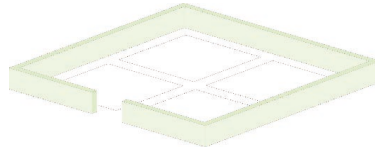

This element characterises all types of cemetery system since its first definition. Spaces dedicated to death have always been surrounded by an enclosure that has played different roles over time, from being a defensive element against tomb raiders, to a perimeter of the blessed space. It not only qualifies and defines the cemetery space, but also has its own well-defined structural behaviour, which is particularly critical from a seismic point of view. Its presence and extension are closely related to the infill process of the cemetery enclosure. Where the infill process of the area has not been completed with columbaria or has been achieved by the successive doubling of the built volumes (e.g.: the cemetery of Finale Emilia) or, again, where the saturation of the cemetery occurs through ground burial (e.g.: in Jewish cemeteries), the perimeter walls represent one of the first elements of vulnerability. During an earthquake, it generates out-of-plane overturning or foundation subsidence mechanisms. An interesting aspect is that, although this element is also present in the naturalistic matrix, it became progressively lower<sup>42</sup> until it disappeared altogether in the new definitions, in the late twentieth century, of forest cemeteries or landscape cemeteries.

- **Crossing element macro-element**

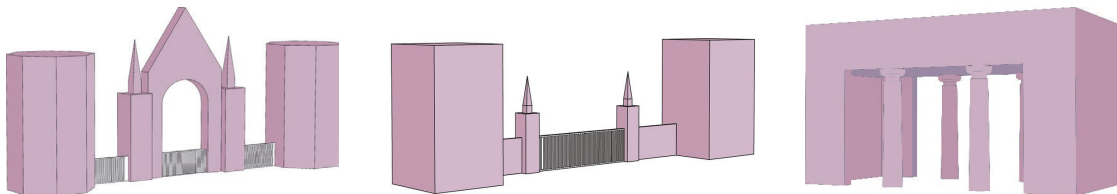

Crossing elements, of which entrances represent the most significant form, are elements of fundamental importance in the funeral ceremony. They represent the element that marks the transition from earthly life to eternal life and for this reason they are often the subject of ennoblement or monumentalisation. In the simplest forms, they are entrances with corbel structural behaviours. However, they are often elements similar to the quadriporticus or atrium if they are installed in structures such as columbaria. They depart from walls or columbaria in which they can be inserted to define independent architectural elements that allude to the concept of passing, of moving from a vibrant environment to a contemplative one.

Further elements can be placed in the entrance area, for use as guardrooms or storage rooms. These are simple box-shaped elements, usually on one or two floors at the most. These annexes are considered to be part of this same macro-element because, while in the case of simple entrances they are built alongside it, in the presence of an atrium or quadriporticus they are incorporated into the structure. Given their function, to be located near the entrances, and their inclusion in the complex configuration of the macro-element (atrium, quadriporticus, and more), it is considered appropriate to include them as part of this macro-element.

.....  
42 Cemetery perimeters built outside the city walls were usually high to dissuade thieves from entering.

- **Columbarium macro-element**

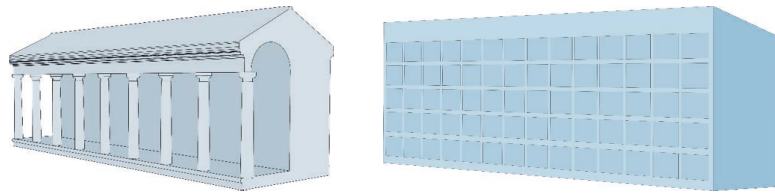

The definition of this macro-element is linked to the changes that occurred in the nineteenth century to optimise the burial space. It represents the reinterpretation of the ancient columbaria elements within the new architecture. This, in its double definition, with or without a porch, thoroughly describes most Italian cemeteries, which belong to the architectural-cemetery typology, in which the columbarium is the main element. It also represents one of the most expensive elements in terms of renovation/restoration after an earthquake, due to the presence of numerous corpses inside it, which must be temporally relocated during the intervention, increasing the cost.

- **Family tomb macro-element**

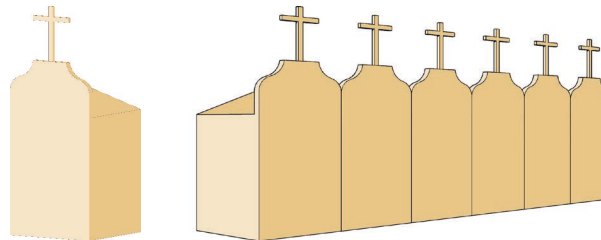

A further macro-element is the family tomb. It is worth remembering that this model spread throughout Italy later, due to a *standardization* of the *typological series process*. Despite being present in the crater area, this element is used mostly where the orographic characteristics make the use of the columbarium complicated or where the social concept of family is still strong, (i.e., in southern Italy). The result, as shown above, is that this can be a single or terraced element, the shape of which is reminiscent of the archetypes of the house and/or the church.

- **Funeral chapel macro-element**

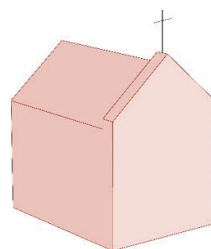

The relationship between churches and cemeteries has always been a complex one. With the separation of cemeterial and ecclesiastical space first, and the removal of cemeteries from the urban perimeter later, it became necessary to provide the structures with a building that would fulfil the functions previously assigned to churches. Cemeteries were therefore provided with what are known as funerary chapels, representing small scale churches. In cases where the cemetery developed close to a church, these may not be present, but they are often still built to support cemetery functions. Being directly descended from churches, funeral chapels retain all of their structural aspects and vulnerabilities.

MACRO-ELEMENT DECOMPOSITION

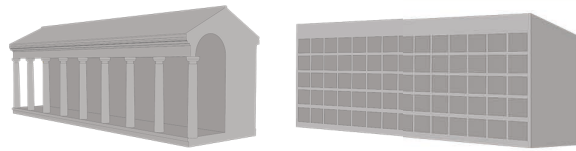
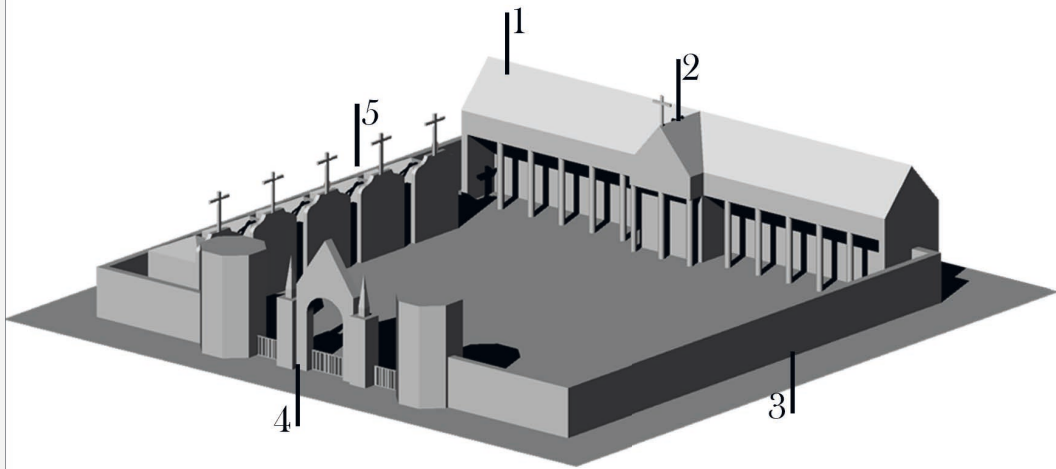

1.COLUMBARIUM

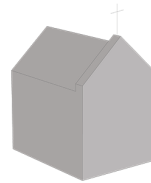

2.FUNERAL CHAPEL

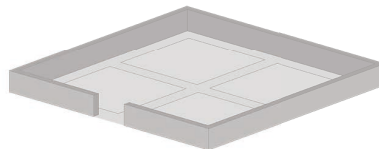

3.ENCLOSURE

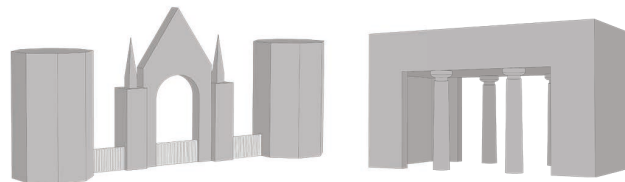

4.CROSSING ELEMENT



5.FAMILY TOMB

Fig.40. Macroelements of cemetery type

# ***CHAPTER 4***

## ***Damage analysis***



On the previous page the Cortile cemetery damaged by the 2012 earthquake

## 4.1. Introduction: motivation, type of data, their consistency and analysis

The earthquake that struck the Emilia-Romagna Region on May 20 and 29, 2012, severely tested a socio-economic system that, alone, produced 2% of Italy's GDP. Nine years later, it is clear that this system has been remarkably resilient, and only the reconstruction of cultural heritage, the last priority set by the Region, is still ongoing. It has been with regard to the field of cultural heritage that the earthquake has made us more aware of the building evolution (Bartolomucci et al., 2012 ), simultaneously testing both its structures and its conservative principles (Dalla Negra, 2012), and this is the reason why reconstruction projects require careful, long-term assessment. In this context, the damage survey is among the first operations to be carried out in an emergency phase, with the difficult task of identifying all the building requirements (structural, conservative and economic). The aim of this survey is to help surveyors in defining vulnerabilities and collapse mechanisms (the information required in order to quantify economic and other not-economic damage) starting with the observation of the cracks (the initial data). This is a quick and simplified procedure which, using a “*behavioural approach*” (Presidenza del Consiglio dei Ministri, 2009:11), is geared towards obtaining homogeneous indication of the damage on a large scale, immediately relating the cracks to the corresponding collapse mechanisms. However, it should also be emphasised that the main critical point of these procedures is that “*...Simplification generally leads to greater data reliability, as long as the ultimate decision-making [...] is well guided*” (Presidenza del Consiglio dei Ministri, 2009:11). It is therefore the relationship between the surveyors, the guided process and the cemetery organisms that, in this case, requires in-depth analysis in order to identify the criticalities encountered during the survey and the corresponding solutions adopted by the officials. The damage survey campaigns and reconstruction projects carried out following the 2012 Emilia earthquake, allowed the collection of data on many damaged cemeteries in the crater area (Fig 1), and this data must be critically analysed to overcome the limits imposed by the existing tools.

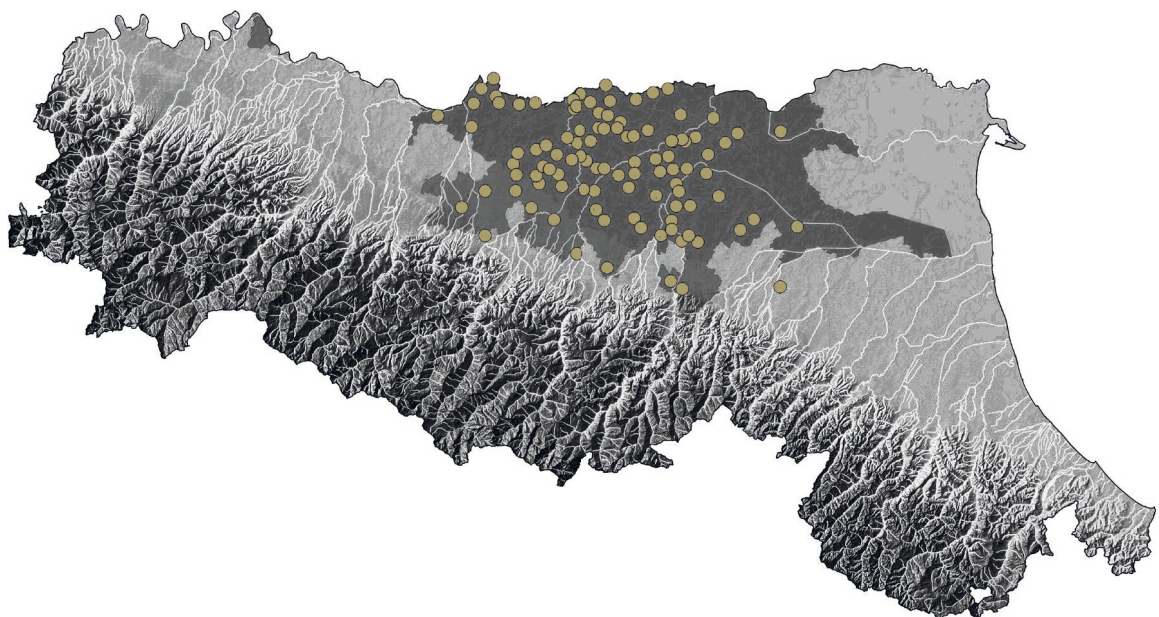
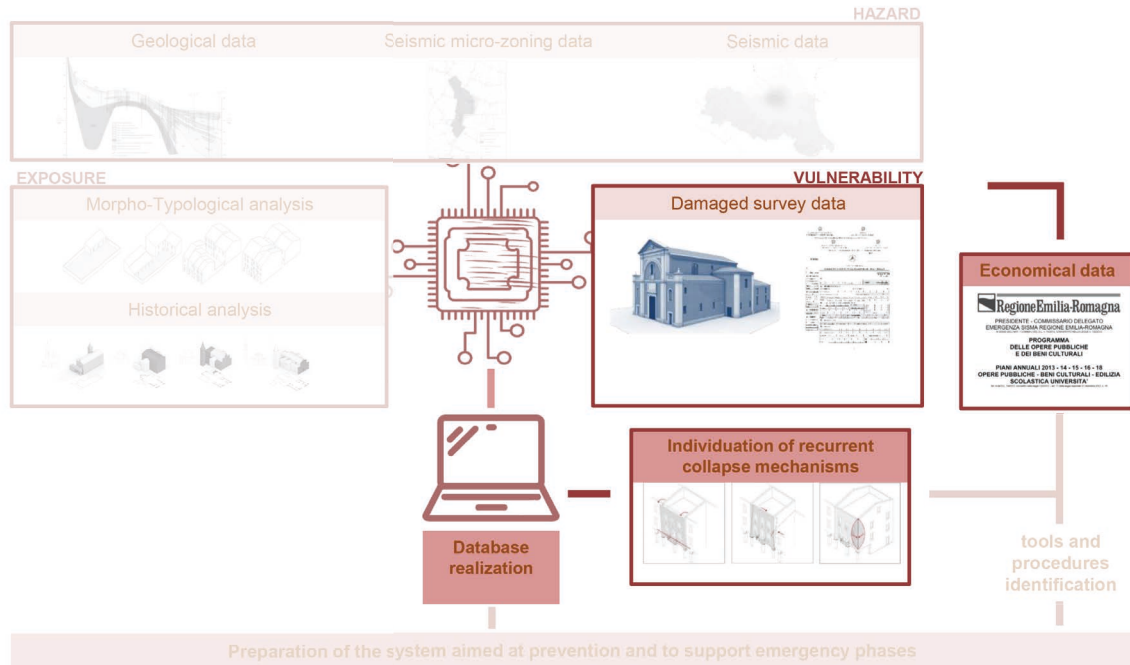

Fig.1. Location of damaged cemetery by the 2012 earthquake within the crater area.

At first glance, these data seem to be a heterogeneous and chaotic mass from which it seems impossible to obtain any information, apart from the ineffectiveness of the current operating survey tools. Actually, the subdivision and reassembly of the data in different classes allows us to outline both the cemeteries vulnerability and the main criticalities of the damage survey tools.



These data are related to the Vulnerability category (see Chapter 2) as their analysis is the basis for the identification of typical seismic behaviours of cemeterial structures, i.e., their vulnerability. The data are of different nature and derive from different phases of the reconstruction process. The types of data, their consistency (for how many cemeteries this type of data is available) and their use are listed below:

- a) **Data from the damage survey.** The data were provided by the regional offices of the MiC (Superintendence, Regional Direction) that had produced them. The set of data consists of two subsets connected by the fact that they belong to the same building. The first one is the actual damage form and is alphanumeric data, the second one is the photographic support created by the officials during the inspections. The first is the critical interpretation of the survey teams who went to analyse the damaged property while the second provides us with a representation of the buildings condition after the seismic event. Although the two subsets should theoretically be composed of the same number of elements, difficulties in finding suitable tools (cameras, phone cameras, etc..) or filing errors have made the subsets incomplete. In the Emilia crater area in particular, 99 cemeteries were surveyed through the cultural heritage damage forms. The damage survey forms of six of these cemeteries are missing, due to filing or digitising errors, three cemeteries have no photographic data and three cemeteries have photographic data corresponding to a different cemetery. In the latter case, the real correspondence between the photos and the cemeteries has been verified and the photographic data have been reassociated, while for the three cemeteries with no photographic data, the possible overlapping with the missing forms has been verified. The result is the following:
- 99 cemeteries were subject to survey, distributed by province as follows: 14 in the Ferrara province, 50 in Modena, 13 in Bologna, 22 in Reggio Emilia.



- 4 cemeteries have no damage survey forms but have photographic data (1 in the Reggio Emilia province, 3 in Modena).
- 2 cemeteries lack both damage survey forms and photographic data (in the Reggio Emilia province).
- 1 cemetery lacks photographic data (in the Bologna province).

The urban cemetery of Correggio and the cemetery of Mandriolo, both in the Reggio Emilia province, have been eliminated from the following analysis as they lack both photographic data and the damage survey forms.

All damage survey forms have been screened and classed as usable. The alphanumeric data have been used for two different purposes, on one hand to comparatively analyse the forms with reference to specific parameters, and, on the other, to identify, together with other data, the geometric-constructive parameters most useful for vulnerability assessments. In the first case, comparative analysis has the dual purpose of verifying both the criticalities encountered by the officials and the validity, where possible, of the macro-elements identified through morpho-typological interpretation and the analysis of construction techniques. In the second case, the data were used to identify the cemetery construction characteristics that may have an influence on seismic behaviour of the structure. In this case, the data of the forms was used together with the photographic data and, where obtained, data extracted from the restoration projects. As far as the photographic data are concerned, these were used in their entirety to identify the collapse mechanisms that occurred during the 2012 earthquake, through the study of the crack scenario, and then, on a statistical basis, to identify those of a recurring nature. While such data cannot provide an objective picture of the damage, as they depend on the vision of the official who carried out the inspection, they represent a very interesting set in order to assess the damage that actually occurred, as it can be verified even almost ten years after the event<sup>1</sup>.

- b) Data from restoration projects.** These data were made available by the Agency, one of the institutions responsible in the Joint Commission for verifying the reconstruction projects of cultural heritage. In this case we are dealing with very different data, which contribute to the definition of the various parts required by a restoration and renovation project. Of all the existing data, those that were most useful were the economic data and data concerning history, pre-intervention conditions, construction and geometric characteristics of the building. In the first case, the economic data were used to perform a preliminary assessment regarding the need to rethink the average economic estimate associated with damage forms in the case of cemeteries, and subsequently to identify a parametric cost that corresponds more to the *type*. In the second case, depending on their type, the data were used to support the analysis of collapse mechanisms or to verify vulnerability parameters. They filled any gaps left by the previous data.

Lastly, it should be noted that, in some cases, verification of the collapse mechanisms was also been carried out by analysing structural data. The use of such data, however, is very rare and strictly connected to the use not so much of structural analyses as to the presence of illustrative reports on the state of damage<sup>2</sup>. The “digital twin”, while allowing easy

.....

<sup>1</sup> Procedure already used since the 1980s (Doglioni et al., 1994; Lagomarsino & Podestà, 2005; etc).

<sup>2</sup> Access to regional funding requires a document that identifies the so-called “causality nexus” between earthquake and damage (Ordinance n. 51 of October 5, 2012).

assessment of building vulnerability as a function of certain construction and architectural parameters, thereby allowing the drafting of vulnerability assessment models, is not always able to return the structural complexity of a historic building when it comes to assessing damage, the product of vulnerability. An example is the experience of structural analysis of the church of Fossa, a suburb of Concordia sulla Secchia, also damaged by the earthquake of 2012. The survey of the crack framework of the façade macro-element indicated the activation of three different collapse mechanisms: the tipping over of the whole façade, of the gable only and an in-plane mechanism. Analysis of the local mechanisms at the limit states LSD and LSV, carried out using the Aedes PCM2015 calculation software, was not satisfied for two of these mechanisms. The analysis indicated that the structure could resist the tipping over of the gable. Nevertheless, the crack framework clearly indicated that the mechanism had been activated (Fig. 2). This result should not be surprising, nor should it suggest an erroneous modelling of the building, since the result indicates that the structure, under normal conditions, would have been able to react to the mechanism activation. In this case, instead, the weakening occurred because the activation of the other mechanisms had affected it to such a level as to activate the third mechanism. In conclusion, these data are not always able to fully capture the damage on real structures.

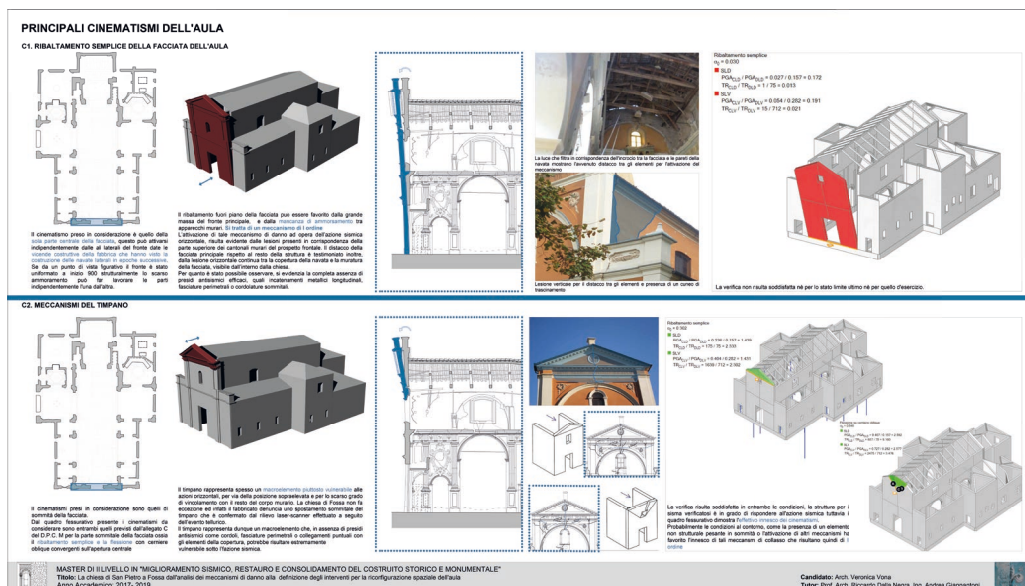

Fig.2. Cracking framework compared with the results of the calculation models for the Church of Fossa. Master Thesis of II level. Student: Veronica Vona. Tutor: Prof. Arch Riccardo Dalla Negra, Ing. Andrea Giannantoni.

## 4.2. Digitisation of forms: first GIS database setup

With the term “digitisation” of forms, the Public Administration, the MiC in this case, generally refers to scanning the paper format and storing the data in .pdf format. This process was carried out also for the damage forms, which were scanned (digitised) immediately after their collection and sent to Rome (Di Francesco, 2014). In order to carry out any kind of analysis, it was necessary to transform the .pdf files into elements with data that could be queried; the decision was therefore made to create a database.

It has been evaluated in advance whether to create a relational database with tabular information only or whether to proceed from the earliest stages to create a relational database

that would also contain geometric data, i.e., whether to create a database on the Access or GIS platform. From a preliminary assessment, it did not appear necessary to combine the geometric data during the first analysis, as these were more tabular than geographical. The acquisition of these data on the Access platform only seemed sufficient, with the preparation of a Primary Key, as the first formulations, would still allow transposition to the GIS environment at a later stage. The decision to create the databases on a GIS platform from the outset depended more on different parameters than on the type of analysis to be carried out. First of all, the decision to create a GIS database allowed to join to the cemetery form database (shapefile), on the basis of interpolation between vector layers, further seismic data, such as the various Pga elaborated by INGV, or Macro-seismic Intensity. Secondly, this decision made it possible to solve some technical problems. The main problem from the organisational point of view was caused by the morphology of the forms and their number. In order to carry out analyses that took all the data into account, it was necessary to create a database covering all three form types, A-DC, B-DP and experimental B. The creation of three separate tables, one per form, although simpler and more immediate, would have made any data comparisons difficult, allowing only separate queries for the different containers. The creation of a single database that would collect all three forms required the identification of common fields, applicable to all forms, generally related to the first and last pages of the forms, and then of different ones, generally associated with the damage survey and vulnerability. Proceeding with the simplification of the data and the unification of all the common fields under a single heading, the number of fields to be created was higher than the possibilities expressed by the Access platform but not by the GIS platform. The decision was therefore made to create a single container for all the forms. Further simplification of the data in order to reduce the number of fields was possible but required a mediated transformation of their content, with the consequent loss of some critical indicator parameters. In some cases, these transformations were still performed to identify additional data, but only after acquiring information from the analyses performed earlier. In conclusion, in order to be able to collect the data as realised within a database, the immediate definition of a GIS database was chosen.

In structuring the database, the following aspects were preliminarily assessed and defined:

- Reference system to be used.
- Structure and content of shapefiles.
- Identification of a primary key useful for future integrations with existing GIS systems.

With regard to the reference system, given the presence of two different zones in the territory, UTM 32 North (west) and UTM 33 North (east), the Region has adopted a reference system in a single zone, initially known as UTMA and now as UTM RER, which envisages the extension of the 32 North zone also to the territory that falls within the 33 North zone, in order to simplify the cartographic applications in its territory<sup>3</sup>. This system, being one of the most widely used in the region, has been adopted for the development of the database.

From the point of view of the structure of the shapefiles, the files that make up a geodatabase, the need to create a system with multiple files joined together, which would allow the management of multiple forms when associated with a single cemetery entity, was immediately clear. The decision was therefore made to adopt an approach based on that

.....  
 3 [https://geoportale.regione.emilia-romagna.it/approfondimenti/copy\\_of\\_i-sistemi-di-riferimento-geografici](https://geoportale.regione.emilia-romagna.it/approfondimenti/copy_of_i-sistemi-di-riferimento-geografici)

defined by CLE standards (see Section 1.3) for the definition of the Structural Units and Structural Building block. This is not the place to discuss structural units in relation to the cemetery survey, because subdivision into different forms is not necessarily related to the actual presence of a structural unit. However, the structure model has been replicated by creating two separate shapefiles. The first, lower in order than the US, collects the damage form data and has been named DAM\_SUR (damage survey), the second, higher in order, as it identifies the cemetery as a unit, collects the main data shared when there is more than one form per cemetery, and has been named CEM (cemetery). The two shapefiles can be linked together using the primary key. This key, also used in subsequent elaborations, has been chosen with the precise aim of both representing a unique value within the database and allowing subsequent integration with other databases. In fact, after the elaboration of the CLE analysis, the Emilia-Romagna Region decided to use the primary keys defined by the CLE coding standard in the information systems created for the monitoring of reconstruction interventions<sup>4</sup>. The use of such a key has the undisputed benefit of being effective not only on regional but also on national scale, defining a unique code for each building that also determines its geographical location within the national context. All things considering, the decision was made to use it as the primary key for shapefiles, calling it ID\_MAN, Identifier of the artifact. The code composition is shown below:

XXX	XXX	XXX	XXXXX	XX
REGION	PROVINCE	MUNICIPALITY	BUILDING STOCK/ CEMETERY	ADDITIONAL CODE FOR BUILDING STOCK/ CEMETERY UNITS

As far as the content of the two shapefiles is concerned, CEM, having to contain the data common to the forms, reports all the names of the buildings<sup>5</sup>, the model(s) of the damage forms used to record it and the different economic data pertaining both to the damage forms (initial estimate) and to the OOPP and BBCC Program (real minimum necessary to repair the building). DAM\_SUR contains the data of the damage forms. As there are three different types of form, a data-entry mask was implemented to access, through the panel, different windows containing either the same fields or those dedicated to the forms.

A mask containing seven panels was created (Fig. 3):

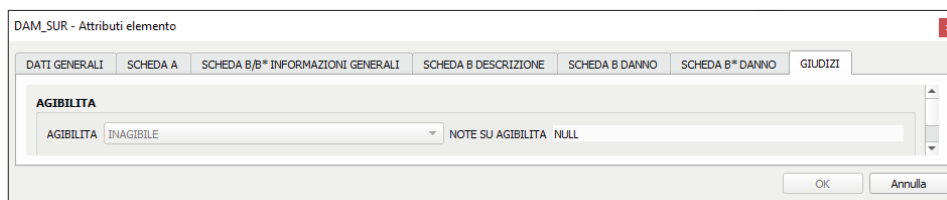

Fig.3. image of the 7 panels created for the input mask.

- PANEL 1 - GENERAL DATA containing the values for the fields from A1 to A5 and from A7 to A13 (form A-DC) or the corresponding fields from B1 to B5 and from B7 to B13 (form B-DP) and the codes for the formation of the primary key.
- Final panel- JUDGEMENTS containing fields A18 to A23 or the corresponding fields B25 to B30.

.....  
<sup>4</sup> This structure was presented by Eng. Maria Romani from the Agency during the conference “Information systems for the governance of historical urban areas” where she gave a speech entitled “Information systems for the monitoring of post-earthquake interventions in Emilia-Romagna”.

<sup>5</sup> Based on webGis for the Cultural heritage of Emilia-Romagna

- FORM A - panel containing data fields A6 and A14 to A18 plus A24, pertinent to form A-DC only.
- FORM B/B\* - GENERAL INFORMATION containing the data common to form B-DP and experimental form B (B\*), with fields B6 and B14 to B18.
- FORM B - DESCRIPTION containing the punctual elements' survey, fields B19 to B22.
- DAMAGE FORM B - panel containing the damage data of form B-DP, fields B23 and B24.
- DAMAGE FORM B\* - panel containing the damage data collected according to experimental form B.

Three images were also uploaded for each damage form taken from the photographic survey, showing the most significant damage in each cemetery (Fig. 4).

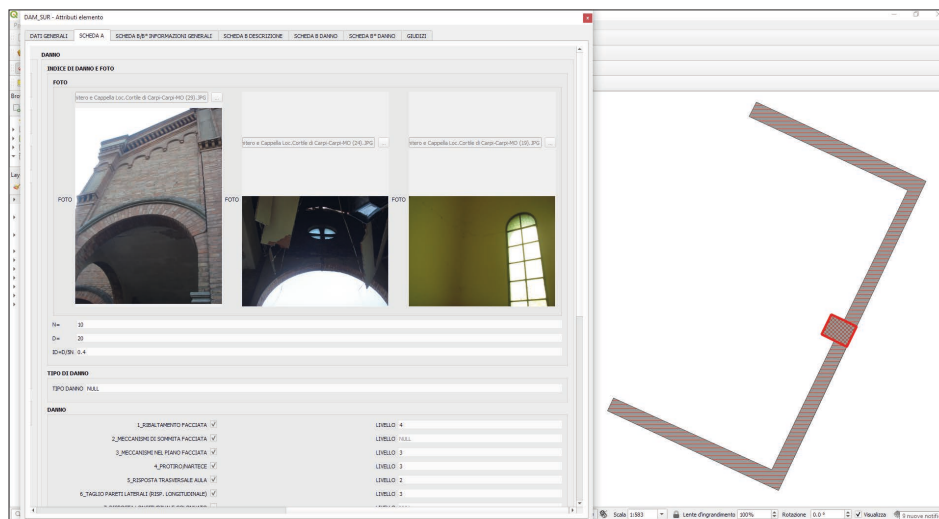

Fig.4. Image of the digitization of the A-DC form of the Cortile cemetery (Modena crater area). The most relevant photos were included in the digital card.

The data forms of all 99 cemeteries were digitised, uploading a total of 129 data sheets onto the database. The data analyses, digitised in open and queryable format, were then carried out.

### **4.3. Analysis of alphanumeric data: identification of weaknesses and macro-element check**

Even though forms A-DC and B-DP are very different in the damage survey section, these were still the only two tools used to survey cemeteries between 2012 and 2013. The first form is closely linked to the architectural and functional aspects of churches, while the second is open to different spatial configurations, as long as they can all be investigated. These, as previously described, require both the filling in of a paper format and the collection of a series of photographic data that will be analysed separately to identify the criticalities affecting the survey process and the collapse mechanisms activated, but also comparatively with specific reference to some survey parameters. The use of these tools, strictly connected to the *type* they describe, despite being the only ones currently available, highlighted the need to intervene with appropriate adjustments, particularly with reference to *types* of a different nature, such as cemeteries. In fact, after the analysis of their application, neither

of these instruments appeared completely suitable for the damage survey of the *cemetery type*. The analysis was carried out through the identification and comparison of the following parameters relating to the forms filled in:

- **type and number of forms filled in per cemetery.** This parameter investigates the type of approach with which the surveyors undertook the survey of the cemeteries in order to verify their homogeneity.
- **correspondence between damage described and observed.** This parameter investigates both the officials' ability to trace the damage back to the existing schemes defined in the forms and their recognition of the cemetery type configurations. In the latter case, this recognition was used to verify that identified in the previous analysis.
- **formal accuracy of the damage index.** This parameter aims to assess the effectiveness of the survey instruments, which differ substantially in the sections devoted to this calculation. The formal correctness of the damage index is, in fact, independent of the correctness of the survey, but depends on the clarity of the forms in terms of the determination of the calculation parameters.
- **differences between tested and experimental forms.** This parameter investigates any positive or negative factors that have emerged from the use since 2013 of a simplified experimental form for the B-DP model.

As a result of the data comparison, the following major criticalities emerged:

- **fragmentation of results due to the use of different forms and numbers of forms, with consequent difficulty in carrying out the economic evaluation.** As there was not a model dedicated specifically to cemetery buildings, the surveyors chose the most suitable model according to their personal opinion, on a case-by-case basis. The answer to this problem in 2012 was therefore ambiguous and followed three different approaches. In some cases, the choice fell on the use of form A-DC form only (Cemetery of Sant 'Agostino in the Ferrara crater area). This preference, which had the certain advantage of embracing all the aspects borrowed from ecclesiastical buildings (chapels with apses, domes, pediments, etc.) probably stemmed from the desire to identify the portico as the most vulnerable element. When filling in the form for the cemetery of Sant'Agostino, both mechanism 5 and 7 were identified as vulnerable, i.e., "transversal response of the hall" and "longitudinal response of the colonnade", so as to be able to insert collapse mechanisms for both forces acting on the portico. By contrast, this form does not face a problem like the large spatial articulation of cemeteries, the wings of which can be damaged in different ways. Probably for this reason, most surveyors decided to use form B-DP, which, being conceived for buildings, divided it into areas, allowing a more articulate description of the damage, considering the responses of the structure and different collapse mechanisms for the different parts. Although from a first analysis, the form seems to allow greater descriptive freedom, it lacks the description of the typical mechanisms of large halls of an ecclesiastical nature. The impossibility of indicating the mechanism in the section dedicated to the calculation of the damage index (although it is often correctly reported in the note) prevents the correct calculation of the index itself. Furthermore, it is the very freedom and descriptive rigidity of the form that cause excessive simplifications in relation to the extension of the cemetery unit. In the

monumental cemetery of Mirandola (in the Modena crater area), with reference to the precise cataloguing of the walls, we come to describe the state of collapse of a portion of them but not the initial collapse of the surrounding areas, therefore indicating only part of the damage. Probably, the need to interpolate both characteristics present in the two forms led a percentage of surveyors to break down the cemetery according to the two models, using form A-DC for the funerary chapel and form B-DP for the remaining areas. Although this choice seems to be the natural solution to the problem of the inadequacy of the single instrument, identifying two types of structures with different structural behaviours, columbaria and funerary chapels, in actual fact it does not provide a uniform indication of the damage to the building.

A further factor increased the fragmentation of the results: the breakdown of the cemetery organism into several micro-organisms acquired with different forms. The use of multiple forms, in the case of form B-DP, is, in fact, allowed but this must be interpreted in analogy with that defined for the Aedes forms: the breakdown can be carried out in relation to the identification of structurally separate units within a complex building. Such schematisation however, due to the very nature of the cemetery, a building in continuous development (see Chapter 3), is not easy to apply. The border between different structural units, is extremely subtle and uncertain if they have not been clearly built in very recent times and with totally different materials and are, consequently, not detectable using cultural heritage models. As a result, the structure was sometimes considered as unified, giving up the compilation of separate forms for each block, while in others it was still divided into several parts (by construction period for example), without which they can necessarily be considered structurally independent. In the first case, there is a summary description of the damage. In the second case, there is also a detailed description for each unit that does not necessarily take into account the probable interaction between the different parts.

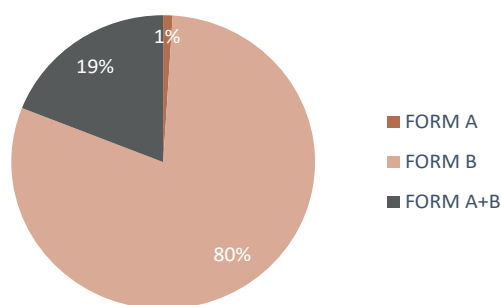

Chart 1. Distribution of type of forms fulfilled.

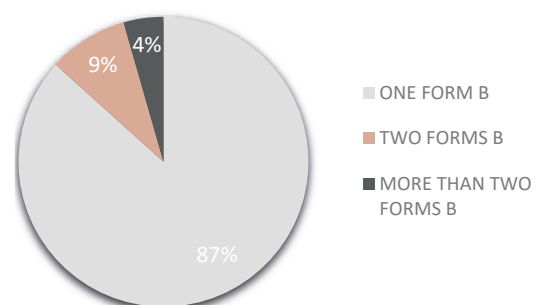

Chart 2. Distribution of number of B-DP forms fulfilled per cemetery.

- difficulty in matching damage and elements within the predefined schemes, with consequent reduction of the damage index Id.** The identification of the macro-elements is the core of the damage survey. Their subdivision and diagrams according to recurrent behavioural patterns are the guidelines followed by surveyors to identify which collapse mechanisms have been activated after the earthquake. Although the 28 mechanisms of form A-DC form and the 22 on form B-DP clearly describe the types for which they have been created, when applied to other types they generated considerable uncertainty. When the surveyors chose a specific tool,

their approach to cemetery type followed different paths. Frequently attempts were made at association by extension of the behaviours of some macro-elements of the forms with the architectural features of the cemetery. On form D-BP for example, an M18 mechanism, “damage to projecting elements”, in the diagrams refers to damage to dormers and balconies. It has sometimes been used to describe damage to gables or attics by extending the concept of projecting elements expressed by form B-DP. A further example is the M21 mechanism, damage to annex structures, sometimes used to indicate damage to some subsequently juxtaposed columbaria. In the case of the cemetery of Cavezzo (MO), however, the annexes included in the recent extension, which should not be surveyed with form B-DP because they are not cultural heritage (Fig. 5). Being different in terms of morphology and types of material (the presence of reinforced concrete compared to the historical part is particularly significant here), they should have been added to the new extension built to the east and surveyed with form AeDES, because their seismic behaviour, considering a good box-like behaviour, is different. In this case, the association by extension of the elements as relative damages led to a mistake on the form.

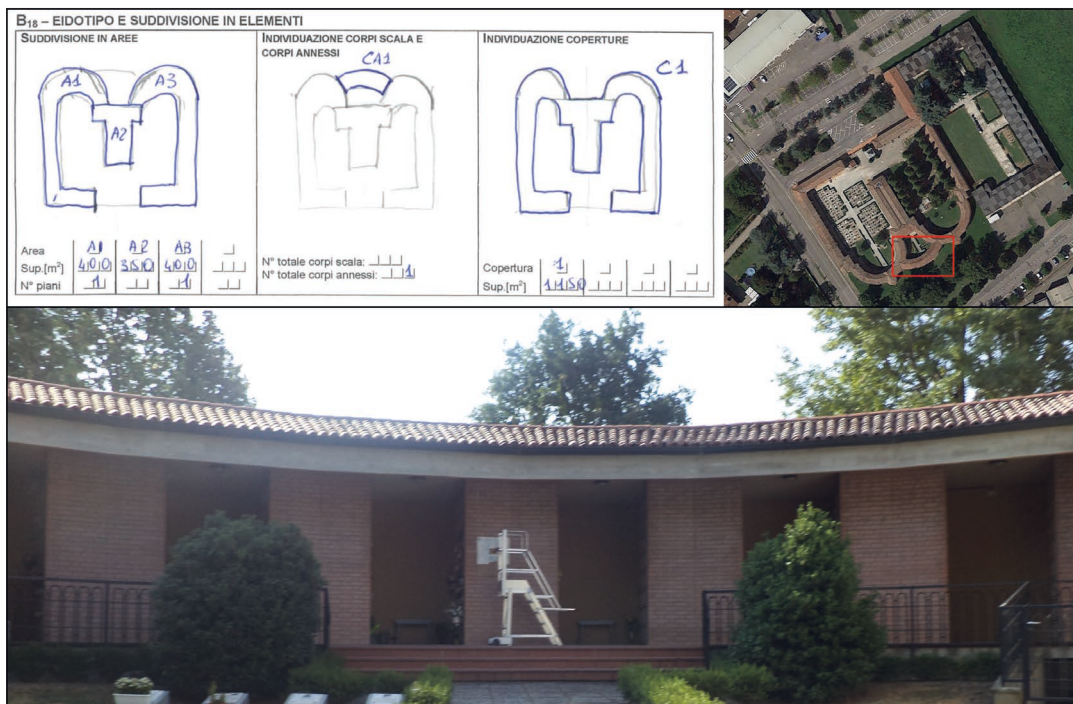

Fig.5. Cavezzo Cemetery (Modena crater area): identification of more recent extensions as “annexed bodies”.

In conclusion, the operation of the extension mechanisms undoubtedly allowed the identification of the level of damage but failed to identify the real mechanisms activated. If we consider the extensive use of this action within the forms, we can see that the tools are not very effective for cemetery buildings. With this in mind, we can mention section B23 of the San Cataldo (MO) cemetery survey, where, out of the five mechanisms identified, two correspond to those entered on form B-DP, two are associated by extension and one is added as a new damage mechanism. In conclusion, out of five mechanisms, three, so more than half, were not recognisable with the form (Fig 6).



**B<sub>23</sub> – MECCANISMI DI COLLASSO STRUTTURALI**

*↳ maggiormente su lato sud del complesso  
riferente a un canale tombato*

TIPOLOGIA	n	CODICE	MECCANISMO
PARETI PERIMETRALI	2	M1	<input checked="" type="checkbox"/> RIBALTAMENTO DELLE PARETI <i>(per muro di cinta sud)</i>
		M2	<input checked="" type="checkbox"/> INSTABILITÀ VERTICALE DELLE PARETI <i>vd. nota</i>
		M3	<input type="checkbox"/> ROTTURA A FLESSIONE DELLE PARETI
		M4	<input type="checkbox"/> RIBALTAMENTO DEL CANTONALE
		M5	<input type="checkbox"/> TAGLIO NELLE PARETI ESTERNE: MASCHI
		M6	<input type="checkbox"/> TAGLIO NELLE PARETI ESTERNE: ARCHITRAVI E MURATURA SOPRSTANTE
PARETI INTERNE	2x	M7	<input type="checkbox"/> TAGLIO NELLE PARETI INTERNE
GLOBALE	<input checked="" type="checkbox"/>	M8	<input type="checkbox"/> SCORRIMENTO DI PIANO
PORTICATI / LOGGE	<input type="checkbox"/>	M9	<input type="checkbox"/> DANNO AI PORTICATI / LOGGE
ORIZZONTAMENTI	3	M10	<input type="checkbox"/> SFILAMENTO TESTA DELLE TRAVI E/O MARTELLAMENTO
		M11	<input checked="" type="checkbox"/> COLLASSI LOCALI DELL'IMPALCATO O DELLA VOLTA
		M12	<input type="checkbox"/> DANNO ALLE VOLTE PER ROTAZIONE DELLE IMPOSTE
		M13	<input type="checkbox"/> DANNO ALLE VOLTE PER DEFORMAZIONE DI PIANO
SCALE	1	M14	<input type="checkbox"/> DANNO ALLE SCALE
COPERTURE	5	M15	<input type="checkbox"/> DANNO NEGLI ELEMENTI DI COPERTURA
		M16	<input checked="" type="checkbox"/> DANNO AL MANTO DI COPERTURA
		M17	<input type="checkbox"/> RIBALTAMENTO DELLE FASCE SOTTOTETTO E TIMPANO
ELEMENTI AGGETTANTI / SVETTANTI	<input type="checkbox"/>	M18	<input type="checkbox"/> DANNO AGLI ELEMENTI AGGETTANTI / SVETTANTI
COLLASSI LOCALI	<input type="checkbox"/>	M19	<input type="checkbox"/> COLLASSI LOCALI PER IRREGOLARITÀ COSTRUTTIVE E DEL MATERIALE
INTERAZIONI	1	M20	<input type="checkbox"/> DANNO PER IRREGOLARITÀ DI FORMA
		M21	<input type="checkbox"/> DANNO NEI CORPI ANNESSI
		M22	<input checked="" type="checkbox"/> CEDIMENTO DI FONDAZIONI
		M23	<input checked="" type="checkbox"/> <i>martellamento x discontinuità costruttiva, che ha</i>
ALTRO	1	M24	<input type="checkbox"/>

*assimilato a questo tipo di meccanismo (M2) lo scivolamento verso il basso del tamponamento del soffarco sull'ingresso PP3.  
generato lesione verticale e all'appoggio dell'architrave.*

Fig.6. Section B23 of the San Cataldo cemetery (Modena crater area): in black, red and blue the official's indications for the assimilation of damages to the marked mechanisms.

In other cases, completely new elements and additional macro-elements from form A-DC were added to form D-BP. As a result, M23 and M24 appear in the list, making it possible to identify damage to apses, gables and tombstones. However, the lack of distinction on form A-DC between structural and non-structural elements led officials to indicate these same elements sometimes as structural damage and sometimes as non-structural damage (Figs. 7 and 8). This distinction, found only on form B-DP, generated such uncertainties that the same type of damage was sometimes used to calculate the Damage Index (structural damage) and sometimes not (non-structural damage). In many cases, not knowing which collapse mechanisms to refer to led surveyors to report minor damage in the note, not including it in the damage index, which was often underestimated.

**B<sub>20</sub> - RILIEVO DEL DANNO AGLI ELEMENTI NON STRUTTURALI**

I COMIGNOLI	II CORNICIONI	III STATUE O AGGETTI	IV RIVESTIMENTI O CONTROSOFFITTI RECENTI
V RETE IDRICA, FOGNARIA O TERMOIDRAULICA	VI RETE ELETTRICA O DEL GAS	VII ALTRO <b>TIMPANI</b>	VIII ALTRO

LIVELLO DI DANNO  
 0 -  assenza di danno 1 -  danno lieve 2 -  danno moderato 3 -  danno grave 4 -  danno molto grave 5 -  crollo

IDENTIFICAZIONE DEL DANNO  
 A - danno sismico  
 B - danno progressivo  
 C - aggravamento

ELEMENTI DANNEGGIATI	Livello di danno	P	LOCALIZZAZIONE	PROVVEDIMENTI DI P.I. SUGGERITI
				PUNTELLAMENTI - RIPARAZIONE - TRANSNATURE - ALTRO
VII	<input checked="" type="checkbox"/> <input type="checkbox"/> <input type="checkbox"/> <input type="checkbox"/>	A1	A1	<input type="checkbox"/> <input type="checkbox"/> <input type="checkbox"/> <input type="checkbox"/>
VII	<input checked="" type="checkbox"/> <input type="checkbox"/> <input type="checkbox"/> <input type="checkbox"/>	A1	A2 (sud-est)	<input type="checkbox"/> <input type="checkbox"/> <input type="checkbox"/> <input type="checkbox"/>
VII	<input checked="" type="checkbox"/> <input type="checkbox"/> <input type="checkbox"/> <input type="checkbox"/>	A1	A2 (sud-ovest)	<input type="checkbox"/> <input type="checkbox"/> <input type="checkbox"/> <input type="checkbox"/>
	<input type="checkbox"/> <input type="checkbox"/> <input type="checkbox"/> <input type="checkbox"/>			<input type="checkbox"/> <input type="checkbox"/> <input type="checkbox"/> <input type="checkbox"/>
	<input type="checkbox"/> <input type="checkbox"/> <input type="checkbox"/> <input type="checkbox"/>			<input type="checkbox"/> <input type="checkbox"/> <input type="checkbox"/> <input type="checkbox"/>

NOTE **TENDENZA DI TUTTI I TIMPANI AL RIBALTAMENTO**

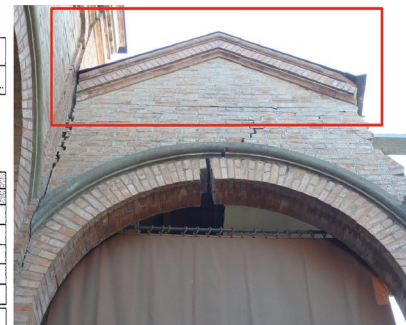

Fig.7. Damage to the gables of the Cortile cemetery: the collapse of the area in the red box, constituting the front wall of the columbarium, has been included among the mechanisms of non-structural elements and therefore not considered in the damage index.

**B<sub>20</sub> - RILIEVO DEL DANNO AGLI ELEMENTI NON STRUTTURALI**

I COMIGNOLI	II CORNICIONI	III STATUE O AGGETTI	IV RIVESTIMENTI O CONTROSOFFITTI RECENTI
V RETE IDRICA, FOGNARIA O TERMOIDRAULICA	VI RETE ELETTRICA O DEL GAS	VII ALTRO	VIII ALTRO PINNACCO CON CRUCE

LIVELLO DI DANNO  
 0 - □□□□ assenza di danno 1 - □□□□ danno lieve 2 - ■□□□ danno moderato 3 - ■■□□ danno grave 4 - ■■■□ danno molto grave 5 - ■■■■ crollo

IDENTIFICAZIONE DEL DANNO  
 A - danno simico B - danno peggroso C - aggravamento

ELEMENTI DANNEGGIATI	Livello di danno	p	LOCALIZZAZIONE	PUNTELLAMENTI	RIPARAZIONE	TRANSENNATURE	ALTRO
UV	■ ■ ■ ■		LAPIDE L. 6, SEPTO T. UPOLO	<input type="checkbox"/>	<input type="checkbox"/>	<input checked="" type="checkbox"/>	<input type="checkbox"/>
IV	■ ■ ■ ■		LAPIDE L. 6, COPPELLE DA	<input type="checkbox"/>	<input type="checkbox"/>	<input checked="" type="checkbox"/>	<input type="checkbox"/>

**B<sub>21</sub> - PERICOLO ESTERNO**

CAUSA POTENZIALE	PERICOLO SU		PROVVEDIMENTI DI P.I. SUGGERITI	
	EDIFICIO	VIA D'ACCESSO	DIVIETO DI ACCESSO	TRANSENNE E PROTEZIONE PASSAGGI
CROLLI O CADUTE DA ALTRE COSTRUZIONI	<input type="checkbox"/>	<input type="checkbox"/>	<input type="checkbox"/>	<input type="checkbox"/>
ROTTURA DI RETI DI SERVIZI/DISSESTI	<input type="checkbox"/>	<input type="checkbox"/>	<input type="checkbox"/>	<input type="checkbox"/>

**B<sub>22</sub> - DISSESTI DI VERSANTE O DEL TERRENO DI FONDAZIONE**

	ASSENTI	PREESISTENTI	GENERATI DAL SISMA	ACUITI DAL SISMA
VERSANTI INCOIBENTI	<input checked="" type="checkbox"/>	<input type="checkbox"/>	<input type="checkbox"/>	<input type="checkbox"/>
TERRENO DI FONDAZIONE	<input checked="" type="checkbox"/>	<input type="checkbox"/>	<input type="checkbox"/>	<input type="checkbox"/>

**B<sub>23</sub> - MECCANISMI DI COLLASSO STRUTTURALI**

TIPOLOGIA	n	CODICE	MECCANISMO
PARETI PERIMETRALI	1/1	M1	<input type="checkbox"/> RIBALTAMENTO DELLE PARETI
		M2	<input type="checkbox"/> INSTABILITÀ VERTICALE DELLE PARETI
		M3	<input type="checkbox"/> ROTTURA A FLESSIONE DELLE PARETI
		M4	<input type="checkbox"/> RIBALTAMENTO DEL CANTONALE
		M5	<input type="checkbox"/> TAGLIO NELLE PARETI ESTERNE: MASCHI
		M6	<input type="checkbox"/> TAGLIO NELLE PARETI ESTERNE: ARCHITRAVI E MURATURA SOPRASTANTE
PARETI INTERNE	2x 1/3	M7	<input type="checkbox"/> TAGLIO NELLE PARETI INTERNE
GLOBALE	<input checked="" type="checkbox"/>	M8	<input type="checkbox"/> SCORRIMENTO DI PIANO
PORTICATI / LOGGE	<input checked="" type="checkbox"/>	M9	<input type="checkbox"/> DANNO AI PORTICATI / LOGGE
ORIZZONTAMENTI	1/1	M10	<input type="checkbox"/> SRIALAMENTO TESTA DELLE TRAVI E/O MARTELLAMENTO
		M11	<input type="checkbox"/> COLLASSI LOCALI DELL'IMPALCATO O DELLA VOLTA
		M12	<input type="checkbox"/> DANNO ALLE VOLTE PER ROTAZIONE DELLE IMPOSTE
SCALE	1/1	M13	<input type="checkbox"/> DANNO ALLE VOLTE PER DEFORMAZIONE DI PIANO
		M14	<input type="checkbox"/> DANNO ALLE SCALE
COPERTURE	1/1	M15	<input type="checkbox"/> DANNO NEGLI ELEMENTI DI COPERTURA
		M16	<input type="checkbox"/> DANNO AL MANTO DI COPERTURA
		M17	<input type="checkbox"/> RIBALTAMENTO DELLE FASCE SOTTOTETTO E TIMPANO
ELEMENTI AGGETTANTI / SVETTANTI	<input checked="" type="checkbox"/>	M18	<input type="checkbox"/> DANNO AGLI ELEMENTI AGGETTANTI / SVETTANTI
COLLASSI LOCALI	<input type="checkbox"/>	M19	<input type="checkbox"/> COLLASSI LOCALI PER IRREGOLARITÀ COSTRUTTIVE E DEL MATERIALE
		M20	<input type="checkbox"/> DANNO PER IRREGOLARITÀ DI FORMA
		M21	<input type="checkbox"/> DANNO NEI CORPI ANNESSI
INTERAZIONI	<input checked="" type="checkbox"/>	M22	<input type="checkbox"/> CEDIMENTO DI FONDAZIONI
ALTRO	<input checked="" type="checkbox"/>	M23	<input checked="" type="checkbox"/> DISTACCO LAPIDE
		M24	<input type="checkbox"/>

Fig.8. On the next page part of the B-DP form for the Cavezzo Cemetery: uncertainty in the classification between structural and non-structural elements. Elements such as pinnacles or tombstones were considered as damage to non-structural elements but then counted among structural vulnerabilities.

We should also consider that cemetery structures are not easily accessible. We refer here to the cross walls of columbaria, where the only part we can see is the wall thickness between the burial niches. We can survey the cross walls of columbaria as a inner wall macro-element of form B-DP, but we cannot recognise any damage using the schemes of pre-existing forms. The diagrams allow us to understand the structural behaviour by observing the cracks mainly from a front wall view or, in challenging cases, by observing them from other sides. It is consequently impossible in cross walls of columbaria to recognise damage by merely observing the wall thickness using the aforementioned schemes, because the expected behaviour and associated cracks for these particular cases are not represented. In the case of cemetery structures damage due to in-plane actions on the cross walls, in fact, presents itself with horizontal lesions on the wall thickness with consequent expulsion of the overlying area (Fig. 9). This damage is complex to understand without specific indications and, as a result, both the macro-element and its damage were often neglected.

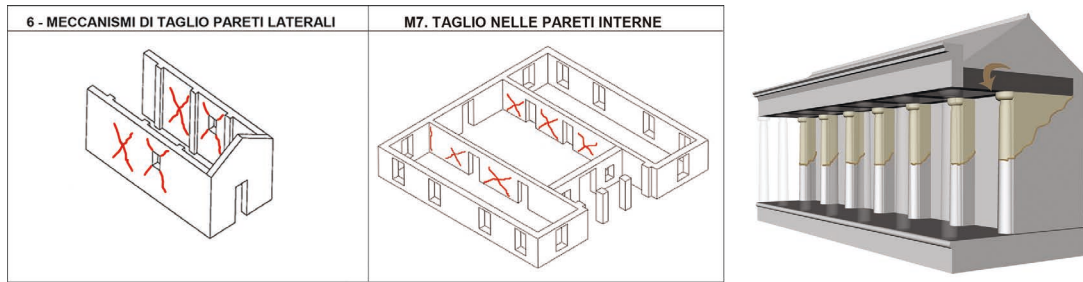

Fig.9. Difference between how shear mechanisms are schematized in existing tools and how it has manifested at cross walls in Emilia-Romagna cemeteries.

A further issue in the damage characterisation process is linked to the experimentation, during 2013, of a new form B (Fig. 10), aimed at simplifying the compilation of the previously adopted form, considered too complex and not very expeditious. The attempt to simplify the new form - which no longer required a detailed description of all the walls, but a twofold rating of the level of damage and the level of vulnerability on a three-value range<sup>6</sup> - proved to be particularly complex for surveyors.

QUADRO DEL DANNO E DELLA VULNERABILITÀ (Rev. 18.11.12)						Danni (% estens.)			Vulnerabilità (% estens.)			D.P.	NOTE
Macroelementi	Tipologia	U.M.	Estensione	Codice	Mechanismo	D <sub>1</sub>	D <sub>2,3</sub>	D <sub>3,3</sub>	V <sub>1</sub>	V <sub>2</sub>	V <sub>3</sub>		
PARETI PERIMETRALI E INTERNE	a	m <sup>2</sup>		M1+2+3+4	MECCANISMI DI PRIMO MODO - PARETI ESTERNE								
	b	m <sup>2</sup>		M5+7	ROTTURA NEL PIANO DEI MASCHI MURARI								
	c	m <sup>2</sup>			"								
	d	m <sup>2</sup>		M6+7	ROTTURA DELLE FASCE DI PIANO								
	e	m <sup>2</sup>			"								
GLOBALE		m <sup>2</sup>		M8	SCORRIMENTO DI PIANO								
		m		M9	ROTTURA PER COMPRESIONE DI ELEMENTI ESILI								
ELEMENTI ESILI	a	m <sup>2</sup>		M10	SFILAMENTO TESTA DELLE TRAVI E/O MARTELLAMENTO								
	b	m <sup>2</sup>			"								
	c	m <sup>2</sup>			"								
	d	m <sup>2</sup>			"								
	e	m <sup>2</sup>			"								
	f	m <sup>2</sup>			"								
	g	m <sup>2</sup>		M11	COLLASSI LOCALI DELL'IMPALCATO								
	h	m <sup>2</sup>			"								
	i	m <sup>2</sup>			"								
	j	m <sup>2</sup>			"								
ORIZZONTAMENTI		m <sup>2</sup>		M11+12+13	DANNO ALLE VOLTE								
		m <sup>2</sup>			"								
		m <sup>2</sup>			"								
SCALE		m <sup>2</sup>		M14	DANNO ALLE SCALE								
		m <sup>2</sup>			"								
COPERTURE		m <sup>2</sup>		M15	DANNO AGLI ELEMENTI DI COPERTURA								
		m <sup>2</sup>			"								
		m <sup>2</sup>			"								
		m		M16	DANNO AL MANTO DI COPERTURA								
ELEMENTI NON STRUTTURALI, ELEMENTI AGGETTANTI / SVETTANTI		num		M17	DANNI ALLE FASCE SOTTOTETTO E TIMPANO								
		num		M18	DANNO AGLI ELEMENTI NON STRUTTURALI								
		num			"								
COLLASSI LOCALI		num		M19	COLLASSI LOCALI PER IRREG. COSTRUTT. E DEL MATER.								
		m <sup>2</sup>		M20	DANNO PER IRREGOLARITÀ DI FORMA								
INTERAZIONI		m <sup>3</sup>		M21	DANNO NEI CORPI ANNESSI								
		m		M22	CEDIMENTO DI FONDAZIONI								
ALTRO													
NOTE													

Fig.10. Image of the page on damage and vulnerability of the experimental B form.

The first difficulty was the clustering of collapse mechanisms into macro-groups. While it is true that the mechanisms depend on two main actions, in-plane and out-of-plane actions, and therefore some mechanisms can be included in either one or the other, this operation makes their detailed identification harder. This approach, in fact, requires the operator to quickly identify the cracks belonging to different mechanisms at once and not just one by one, an operation that is already difficult even for the

.....  
<sup>6</sup> Values in this case are no longer coordinated with the European legislation on the scale of damage, but related to the extent of damage and vulnerability in percentage terms.

most skilled technicians. It should also be noted that the introduction of the macro-element vulnerability rating on a three-value scale is hard to interpret. First of all, since this is a level I form, which does not investigate anti-seismic structures or risk reduction factors, all macro-elements should be considered only vulnerable or non-vulnerable. A vulnerability scale ranging from 1 to 3 requires a vulnerability analysis of an element in comparison to the whole building, which cannot be carried out in the emergency phase. It probably replaced the “risk indication” section associated with individual damages on form B-DP, however the term “vulnerability” led to its being filled in regardless of whether or not the element was damaged. Even if this refers to the elements’ vulnerability and not to the indication of an imminent risk, without any knowledge of the materials, the chains, the presence of spandrels or spurs along the whole extension of a vaulted portico, and all data that would require in-depth inspection, it does not appear possible to correctly identify how many of the elements are actually vulnerable and to what extent.

In conclusion, while from the point of view of the number of pages to be filled in, the form seems to be more expeditious, decreasing from a minimum of 4 pages to 1, it actually requires the definition of a complicated series of data that the officials found it hard to detect. The damage section was not filled in on about 50% of the experimental forms, often preferring a detailed description of the damage in the notes, and there are numerous cemetery forms where the percentages are entered accompanied by question marks next to them. As a result, we collected a set of unreliable and inconsistent data. As there are no clear and univocal guidelines, a correct survey depends primarily on the operator’s ability to summarise the behavioural cemetery features without necessarily having any previous knowledge, and then on relating them to the existing tools.

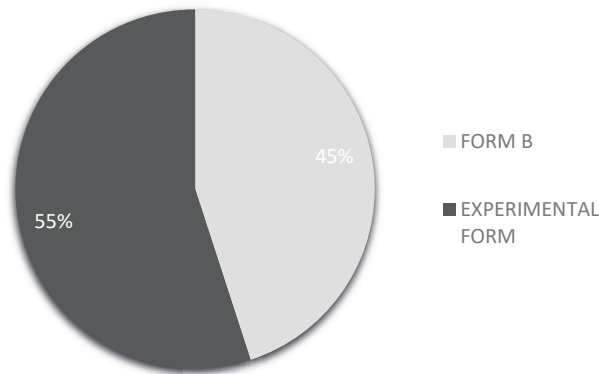

Chart 3. Distribution of B-DP forms and B experimental forms fulfilled.

- Errors in damage index calculation due to intrinsic criticality of the B-DP form.**  
 The identification of the damage index is one of the final aims of the damage survey. In addition to providing an overview of the damage, the index should also identify a parametric cost to be multiplied by the building area. It is therefore one of the two fundamental results for damage survey operations<sup>7</sup>. With the same index formula,  $Id = d/5N$ , the parameters “d” and “N” are counted differently in the two forms, but in both,

.....  
<sup>7</sup> The second is the assessment of the practicability which, unlike the AeDES forms, is not directly connected to the damage but depends entirely on the expert judgment of the surveyors.

the expected result is a number on a scale from 0 to 1, where 0 indicates the absence of damage and 1 the almost total collapse of the building (Grüntal,1998 ) (Fig. 11).











Classificazione del danno a edifici in muratura		Classificazione del danno a edifici in cemento armato	
	Grado 1: Danno da trascurabile a leggero (nessun danno strutturale, leggero danno non strutturale) Crepe capillari su pochissimi muri. Caduta di piccoli pezzi di intonaco. Caduta di pietre non fissate dalla parte superiore degli edifici in pochissimi casi.		Grado 1: Danno da trascurabile a leggero (nessun danno strutturale, leggero danno non strutturale) Crepe sottili nell'intonaco sopra elementi dell'intelaiatura o nei muri alla base. Crepe sottili nei tramezzi e nelle tamponature.
	Grado 2: Danno moderato (leggero danno strutturale, moderato danno non strutturale) Lesioni in molti muri. Caduta di pezzi di intonaco piuttosto grandi. Parziale collasso di comignoli.		Grado 2: Danno moderato (leggero danno strutturale, moderato danno non strutturale) Lesioni nei pilastri e nelle travi delle strutture a telaio e nelle pareti portanti. Lesioni in tramezzi e tamponature: caduta di rivestimenti esterni ed intonaco. Malta cade dai giunti dei pannelli murari.
	Grado 3: Danno da sostanziale a grave (moderato danno strutturale, grave danno non strutturale) Lesioni larghe diffuse sulla maggior parte dei muri. Tegole si staccano. Comignoli si frantumano alla base; cedimento di singoli elementi non strutturali (tramezzi, comicioni).		Grado 3: Danno da sostanziale a grave (moderato danno strutturale, grave danno non strutturale) Lesioni alla base dei pilastri e nei nodi delle strutture a telaio; lesioni alle intersezioni delle pareti accoppiate. Espulsione del copriferro, instabilità delle barre dell'armatura. Larghe lesioni in tramezzi e tamponature, cedimento di singoli pannelli.
	Grado 4: Danno molto grave (grave danno strutturale, danno non strutturale molto grave) Importanti cedimenti dei muri. parziale cedimento strutturale di tetti e solai.		Grado 4: Danno molto grave (grave danno strutturale, danno non strutturale molto grave) Larghe lesioni in elementi strutturali con cedimento a compressione del cemento e rottura di barre d'armatura; sfilamento delle barre di armatura; inclinazione dei pilastri. Collasso di alcuni pilastri o di un singolo piano alto.
	Grado 5: Distruzione (danno strutturale molto grave) Collasso totale o quasi totale.		Grado 5: Distruzione (danno strutturale molto grave) Collasso del piano terra o di parti (es. ali) di edifici.

Fig.11. European damage classification scale for masonry buildings (Grüntal, 1998).

The difference in calculation has led to many mistakes. If the setting of form A-DC (collapse mechanism on macro element: activatable YES/NO + damage level from 0 to 5) is unlikely to lead to incorrect compilation, the situation is different for form B-DP. In general, the cause of these calculation mistakes lies in the similarity of formula between the forms and the lack of a formally approved manual for form B-DP. Being familiar with the older form A-DC led surveyors to use the same calculation when dealing with the same formula, while the length and fragmentary organisation of data on form B-DP form generate several miscalculations (in one section, you have to indicate the extent of damage of each element, in another the number of macro-elements - corresponding to the elements detected before - and the activated mechanisms, in a third the level of damage level on the activated mechanism, element by element). The most common mistake in “d” calculation is the non-attribution of a “secondary” parameter, overestimating the damage. As far as the “N” parameter is concerned, we can find several errors related to the unclear architecture of the table containing the parameters for its definition.

The main errors, made systematically, are:

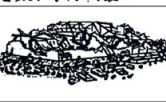
- failure to count the pre-marked parts (as global mechanism or bottom subsidence);
- the incorrect counting of macro-elements (indication of a number of macro-elements different from those detected in the previous section);
- failure to multiply inner wall macro-elements (indicated on the form);
- the multiplication of the macro-elements by the collapse mechanisms activated, seriously overestimating the “N” parameter.

The end result is an inaccurate identification of the two parameters “d” and “N”. As regards the cemeteries damaged by the 2012 earthquake in Emilia, even considering

the damage survey carried out with correct compilation of form B-DP<sup>8</sup>, this results in incorrect damage indices. In particular we face with an improper identification of the parameters leading to damage indices which are in some cases only slightly incorrect, as in the case of the cemetery of Cortile in Carpi (in the Modena crater area), where the corrected index differs by only the second decimal place from that indicated. In other cases, such as the cemetery of San Giovanni in Concordia Sulla Secchia (in the Modena crater area), the index is greater than one, giving a meaningless result.

- **Absence of damage index for experimental form B.** In addition to the miscalculated indices with B-DP form, another problem resulted from the removal of this index from the experimental B form. This choice is undoubtedly related to the creation of a commission in charge of the economic evaluation of the assets after the survey. Since officials were no longer required to estimate the cost of building restoration on-site, it was no longer necessary to have a parameter to refer to when calculating the cost. This decision, however, is valid in relation to the effectiveness of the survey instrument: if the survey is performed properly, even staff who have not carried out the inspection can identify the “*objective parameters*” (Di Francesco, 2014) for the economic calculation of the cost of the intervention. The real effectiveness of the tool for buildings of the *type* for which it was designed is unknown, but 50% of the experimental B forms left empty for the *cemetery type* undoubtedly had a negative impact on the subsequent calculation. It should also be added that the lack of need to reach a damage index, however wrong it may have been, and therefore to reach an economic estimate, probably influenced the officials’ decision not to fill in the form, seeking a mediation between how the instrument was designed and what they saw. As they were no longer required to indicate a cost and as they were not aware of the parameters of the subsequent evaluation, they delegated the task of informing the evaluation committee of the damages from which to draw their subsequent conclusions to the photographic survey carried out. At the end of the cemetery survey, more than 50% of the forms had no Id and the rest had a low percentage of correct Id, mostly connected to the survey of the funerary chapel only (obtained from the A-DC form).

In addition to the criticalities listed above, the analysis of the B forms, both in the approved B-DP and the experimental B form, especially when compared with each other, also allows us to identify some positive factors. This analysis preliminarily required transformation of the data from the experimental form B and B-DP in order to compare them with each other. Due to the significant number of forms left empty in the damage and vulnerability analysis fields with corresponding damage described in notes, the notes were transformed into the corresponding damage survey. This, however, was acquired and then analysed as presence/absence only because, based on the description it was not possible to assess the level of damage as intended by the surveyor. The transformation of the damage into a value on a scale from 1 to 5 would have meant a second elaboration, which would have been possible but not useful for the ultimate purpose of understanding the problems faced by the officials during the surveys. After this operation, if we evaluate the number of mechanisms considered activated after the 2012 earthquake

.....  
8 It is assumed that all damage has been detected, even if it has not been correctly assigned to its macro-elements.

using the two forms, at first glance we could identify a further criticality introduced by the experimental form: the performance of two completely different and non-homogeneous surveys, despite the same abacus of collapse mechanisms (Charts 4 and 5).

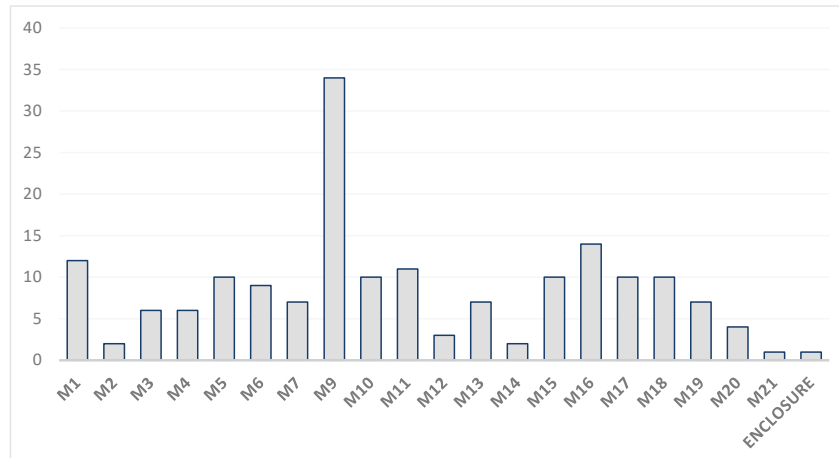

Chart 4. Damage distribution in B-DP forms.

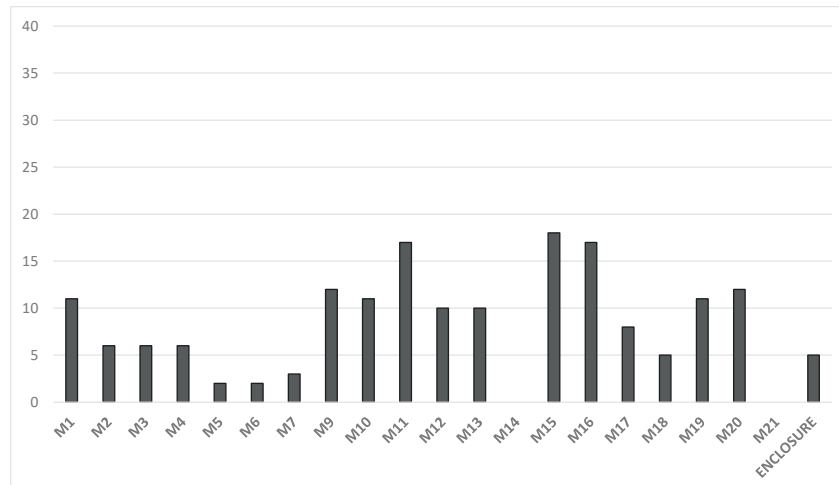

Chart 5. Damage distribution in experimental B forms.

The damage survey carried out in 2012 with B-DP form shows a prevalence of the M9 damage mechanism, while, although still present, this predominance decreased significantly in the 2013 survey using the experimental form. Conversely, mechanisms from M10 to M13, which were hardly identified in 2012, appeared to increase. This, however, is not related to the activation of different collapse mechanisms in cemeteries, but shows how much the design of these forms influences the surveyors' choices and how the use of unsuitable tools can lead them in completely different directions. Between the B-DP form and its simplified version, there was a change in terminology that drastically changed the survey. The form adopted identifies mechanism M9 as damage to porticos and loggias. This definition seems to include both in-plane and out-of-plane mechanisms. Moreover, the scheme associated with this damage displays cracks in columns due to compression, cracks in the longitudinal direction of arches and cracks in the vaults. This has led to a significant reduction in the identification of other mechanisms, such as M12 and M13, damage to vaults and floors, which were considered already included in M9. In the 2013 simplified form, the same M9 mechanism was defined as damage of slender elements by compression, associating the

damage to the compression of columns only. This definition increased the identification of collapse mechanisms related to vaults and floors (from M10 to M13).

Lastly, it is worth noting that both the recognition of vulnerabilities due to irregularities in construction (M19) and shape (M20) and the preference to consider surrounding walls as a new macro-element increased. Consequently, it is indisputable that the experimental B form led the surveyors to make very different choices compared to form B-DP. However, this allows us to identify some positive elements:

- **Recognition of columbarium portico damage as the main damage to cemeteries in Emilia-Romagna.** The recognition of the columbarium portico as the main vulnerability was already evident from the analysis of the form B-DP results alone, where the M9 mechanism is that identified most frequently. Experimental B form, on the other hand, allows us to identify the distinction of the different types of damage that occurred, which were all collected within a single mechanism on B-DP form. In fact, damage from the compression of columns, damage to vaults and collapses of flat floors are identified on experimental B form. However, it should be emphasised that, since the tipping over of the portico represents the main collapse mechanism of portico structures in cemeteries in Emilia-Romagna, the recognition of mechanism M1, tipping over of the outer walls, should also have increased in the survey conducted in 2013. The absence of such increase can be explained in two different ways. A first hypothesis can be related to the fact that the cemeteries analysed did not present such characteristics as to consider the tipping over of the portico possible (large pillars, relatively recent and well-connected structures etc.). A second hypothesis deals with the node macro-element. If, on form B-DP, the portico macro-element was so inclusive as to reduce the identification of damage, on the experimental form, the decomposition of the macro-element into its components (columns, attic fascia, vaults, floors...) implied the non-recognition of all possible behaviours.
- **Recognition of recurring damage typical of growing structures such as cemeteries on experimental form B + Recognition of the surrounding wall as a macro-element.** These two factors are dependent, more than on the form itself, on an additional parameter associated with the survey carried out using experimental B forms: the surveyor. In 2012, twenty-seven people carried out the survey filling in an average of two forms each. In 2013, there were only seven surveyors, as shown in Charts 6 and 7. Four out of seven surveyors completed no more than two forms each, while the remaining three carried out most of the survey. The first two surveyors (surveyor 1 and surveyor 2) were involved in most of the survey operations together, alternately signing the forms or the photographic apparatus<sup>9</sup>, and can therefore be considered a single surveyor entity. In the second case, the surveyors gained more knowledge about cemetery type by visiting a larger number of cemetery buildings. Consequently, the surveyors improved their abilities in the identification of vulnerabilities and damage that they understood to be recurring. What results is the damage assessment for the discontinuities typical of extensively articulated structures under constant development, i.e., the damage caused by irregularities in shape and construction features (M19 and

.....  
9 Fields B12 and B13 of the forms.



M20) and the identification of the surrounding wall as an element to be assessed separately, confirming the identification of the macro-element in Chapter 3.

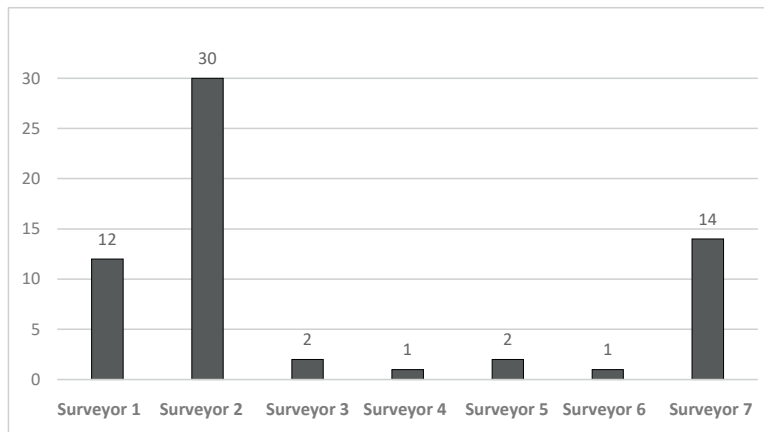
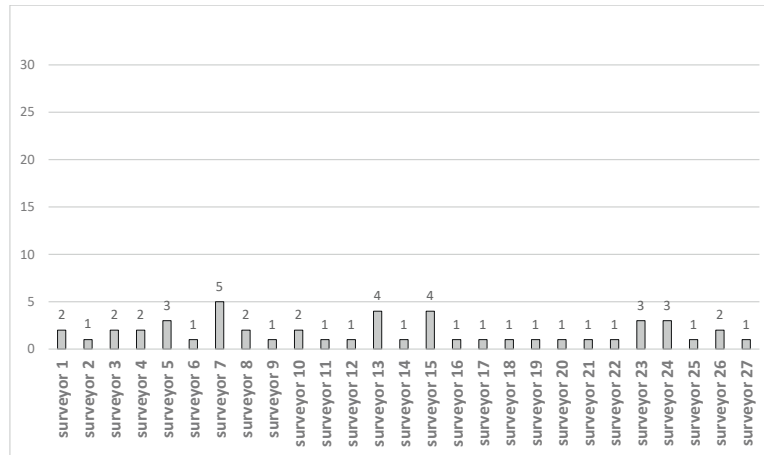

Chart 6 and Chart 7. Ratio between surveyors and number of cemeteries surveyed with B-DP and experimental B form.

In conclusion, from this analysis it is possible to identify some useful suggestions for the implementation of a new scheduling tool. First of all, it is possible to state that the morphological and structural distance between certain building's *types*, such as the cemetery, and the existing damage survey instruments, not specifically designed for them and applied in search of the most suitable solution case by case, is the cause of incorrect damage surveys. As it was not possible to calculate a univocal and correct damage index, it was also hard to properly describe the damage caused to cultural heritage and identify a correct parametric cost, affecting the subsequent reconstruction phase. Moreover, mistakes in the application of the damage index formula on B-DP form also confirm the ongoing request by the officials and technicians accompanying them to improve the tool adopted in terms of speed and clarity. From this point of view, the introduction and failure of experimental B form also remind us that the design of these instruments is a long-term process, the success of which is achieved by mediating between the needs of speed and those of data accuracy, never neglecting to consider the real users of these tools. Lastly, the choices made by the officials between 2012 and 2013 confirm the decomposition of the cemetery organism into certain macro-elements such as: columbaria, funerary chapels (on which the use of multiple forms depended) and the surrounding wall (already present on form B-DP but clearer on experimental form B).

## **4.4. Analysis of photographic data and identification of collapse mechanisms**

With the twofold aim of identifying the data useful for the definition of a new tool and of defining the terms of comparison through which to investigate the real ability of the surveyors not only to identify the damage caused to cemeteries but also to record it on the existing forms, the identification of all the damage mechanisms for the cemetery *type* in Emilia-Romagna crater area was preliminarily performed. In order to achieve this aim, a critical survey of the crack framework, which emerged after the earthquake and was collected in the photographic documentation compiled by the surveyors, was carried out. The critical interpretation of the crack pattern, now common practice for historical buildings, stems from the reading of masonry mechanics by Giuffrè (Giuffrè, 1991) but also from studies conducted by Mastrodicasa (Mastrodicasa, 1958) on the diagnosis of instabilities. The cracks, the natural expression of the collapse mechanisms, were then analysed to understand which kinematic mechanisms were activated. This analysis did not take into account the order of the cracks<sup>10</sup>, despite preliminary observations, as the aim was to identify all the possible kinematic mechanisms for the type and not to make an assessment more useful to a restoration and consolidation project.

Unfortunately, by 2018, the cemeteries had almost all been restored or were in the process of being restored and the few in which repairs had not yet been carried out were those with little damage (the Monumental Cemetery of Finale Emilia in the Modena crater area for example). With the exception of a few singular cases, therefore, it was not possible to acquire the state of damage first-hand, having to rely on photographs. However, this operation is common to many studies in this field, such as that conducted by Doglioni, who used photographic data collected after the 1976 earthquake in Friuli to carry out his study in the late 1980s. The mechanisms abacus was therefore based on the morphological analysis previously described for the identification of macro-elements and on the structural analysis of the actual recurrent damage observed from the photographic data accompanying each inspection carried out between 2012 and 2013.

- **Surrounding wall mechanisms**

The surrounding wall macro-element is one of the most common elements in the cemetery building. In the case of the Emilia-Romagna cemeteries, out of the 99 cemeteries investigated, 63 had this element. Its presence and extension are closely related to the infill process of the cemetery enclosure. Where the infill process of the area has not been completed with columbaria or has been achieved by successive doubling of the built volumes (e.g.: the Finale Emilia cemetery) or, again, where the saturation of the cemetery occurs through ground burial (e.g.: in Jewish cemeteries), the surrounding wall represents one of the main elements of vulnerability. During an earthquake, it generates the activation of three elementary mechanisms

.....  
<sup>10</sup> The individuation of the cracks order represents a further in-depth analysis of the crack framework, as it indicates which mechanisms have been activated by the direct seismic action and which by the activation of other mechanisms. This analysis is extremely importance in the project phases relating to historical buildings, in order to limit improvements to what is really necessary (Giannantoni, 2013).

- out-of-plane tipping over. This is the easiest mechanism to activate due to the nature of the macro element itself, a corbel fastened to the ground. Sometimes, spurs are present to prevent its activation, but they have not always been effective: it was activated in about 70% of cases. Vertical cracks, where the masonry is poorly clamped, or with an inclined trend in the masonry (Figs 12-13) appear when the mechanism is activated.

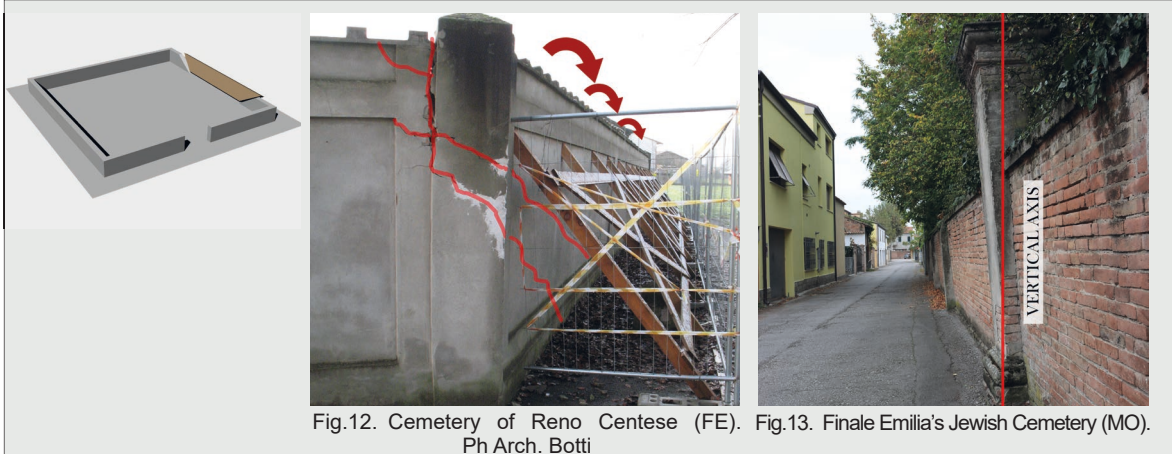

- corner ejection: the presence of corners within the fenced perimeter is also dependent on the *infill process*. There are many cemeteries in which this process has come almost to a conclusion by narrowing the surrounding perimeter to just the wall at the entrance. The mechanism is revealed by inclined cracks and the outward tilting of the corner (Fig. 14).

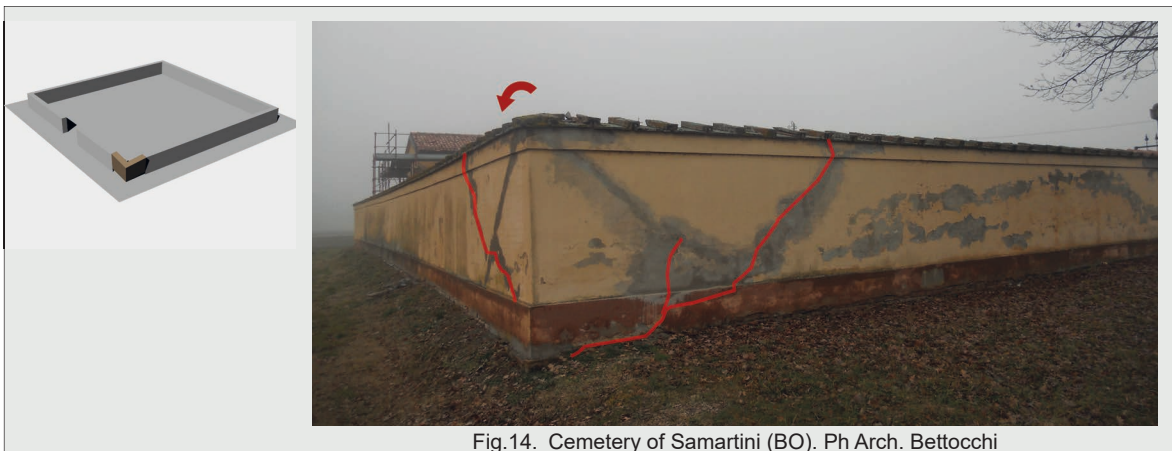

- foundation subsidence: this mechanism is due to ground movement rather than to an intrinsic vulnerability of the element (Fig. 15). It was activated in only 5% of the cases.

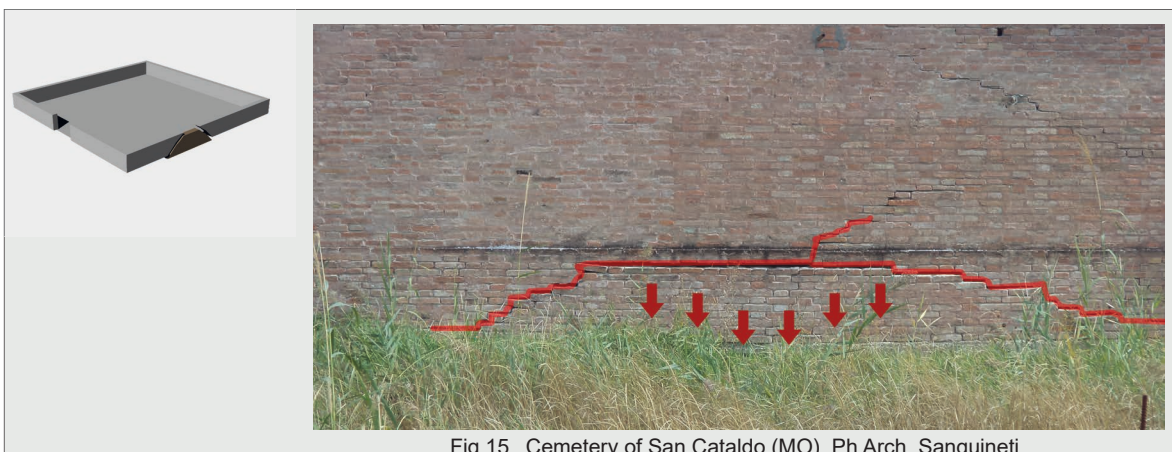

These mechanisms occurred with the different recurrence shown in Chart 8 below.

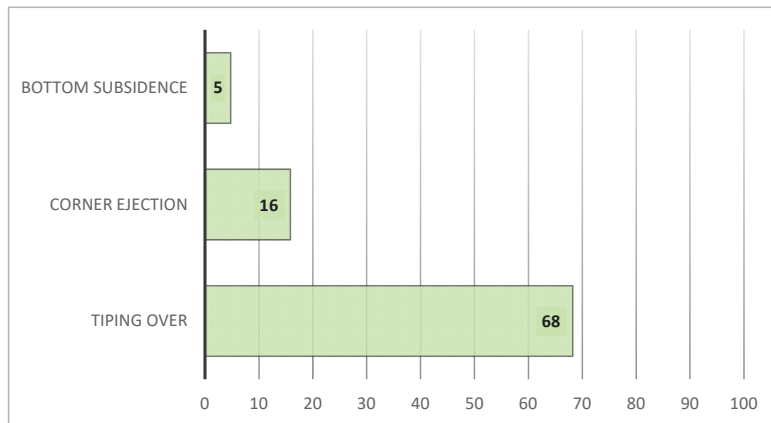

Chart 8. Surrounding walls collapse mechanisms (%)

- **Crossing element mechanisms**

In the case of crossing elements, it is necessary to distinguish between entrances that are structurally corbels, with or without secondary construction, and elements covered by compartments. The first case is typical when the macro-element is combined with the surrounding wall macro-elements. In this case, the element is also configured as a corbel which may take on varying monumental status depending on the importance of the cemetery. The monumental status of the entrance is closely related to the element’s vulnerability, which increases as the former rises. As with brick masonry buildings, the higher the wall of the element rises and is adorned with decorative elements, the more vulnerable it becomes to out-of-plane actions of the earthquake.

The macro-elements of entrances that are structurally corbels are:

- Tipping over of the walls. An out-of-plane collapse mechanism with its horizontal hinge not necessarily on the ground but often also at the end elevation of the adjacent surrounding wall (Fig. 16). It is therefore identifiable by the presence of horizontal cracks in the surface of the wall. This occurred in 24% of the elements, which is actually a very high percentage if you consider that it takes into account all the entrances, from the most naturally vulnerable (high walls) to those least vulnerable (very low walls).

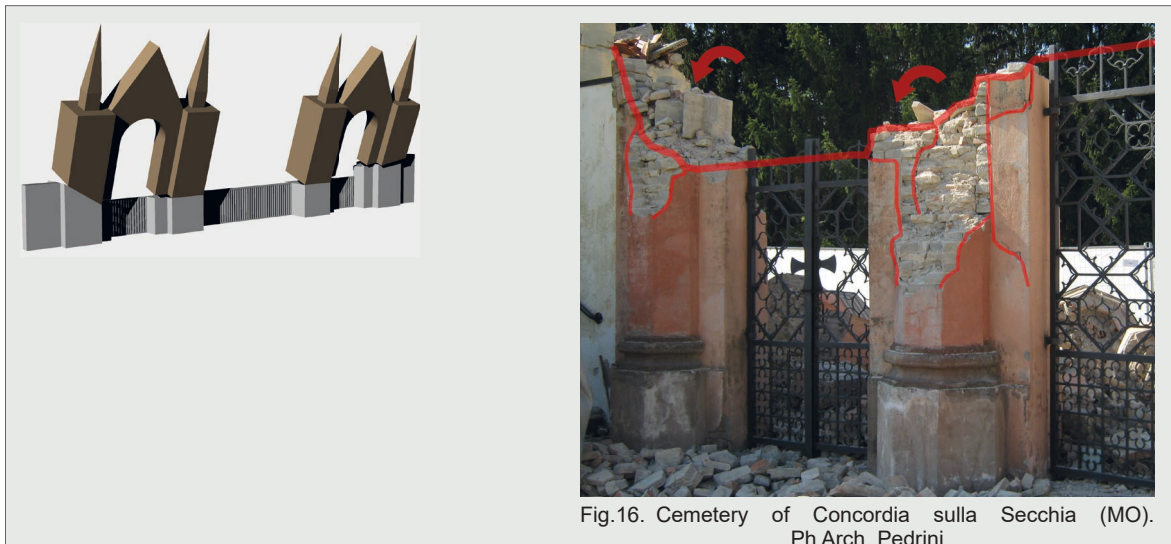
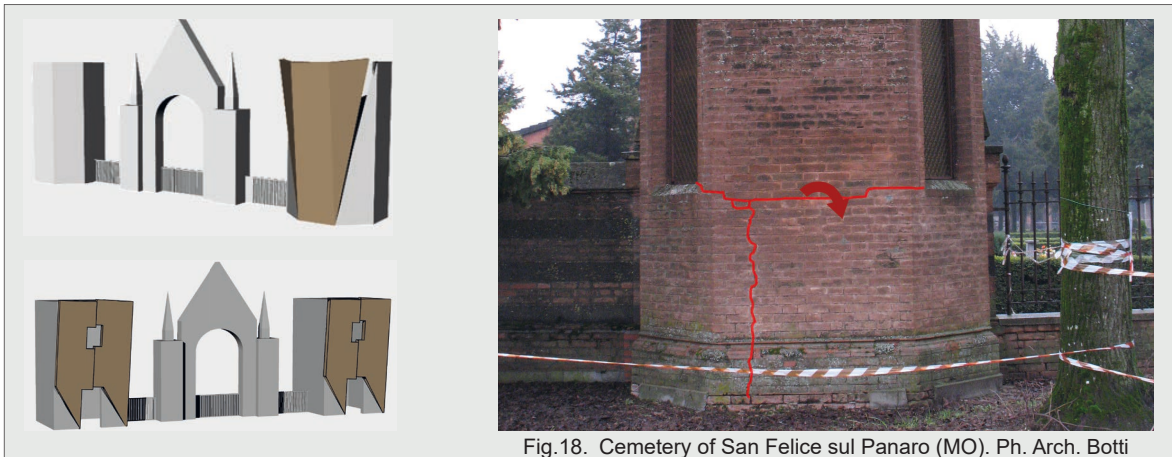

Fig.16. Cemetery of Concordia sulla Secchia (MO). Ph Arch. Pedrini

- Tipping over of projecting elements. These elements are particularly present in monumental entrances where pinnacles and other elements are used to highlight the entrance. They represent a very vulnerable point and, where present, are often collapsed or damaged (Fig.17).



- Damage to accessory spaces. The entrances can be combined with simple buildings in which the guardhouse or material collection functions are housed and which, when covered by compartments, are absorbed into the macro-element itself. These are simple elements, with few openings and generally good reaction to earthquake. In this case, although rare, both out-of-plane and in-plane mechanisms may occur in the façades (Fig. 18).



- Damage from interaction with other macro-elements. The movement of other macro-elements to which the entrances are connected, surrounding walls or columbaria, caused additional damage to the structures (Fig. 19).

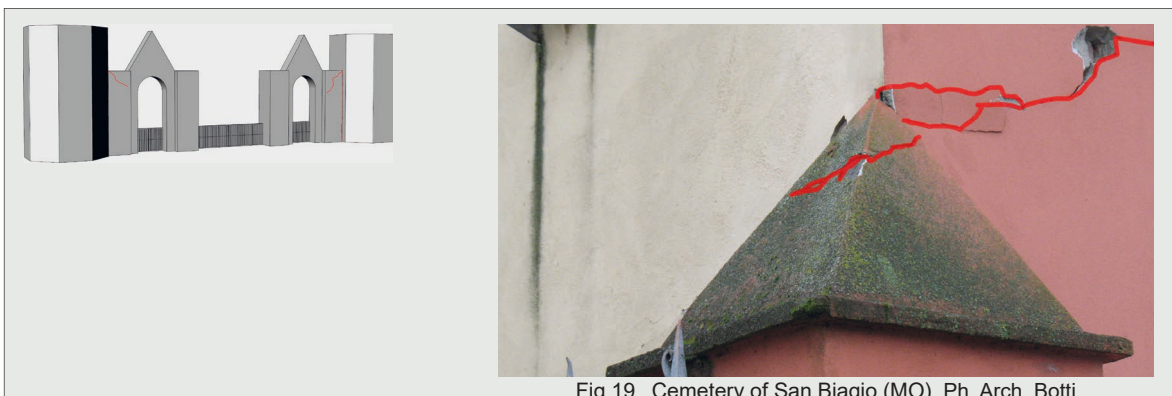

The mechanisms for structural corbel elements exhibit an almost homogeneous recurrence (Chart 9) mainly due to the presence of few monumental entrances. This lack of vulnerable elements, however, rather than being a structural phenomenon of the cemetery's composition, is closely related to the sample under investigation, cemeteries of small-medium size. In fact, as the importance of the cemetery increases, the entrances become more monumental.

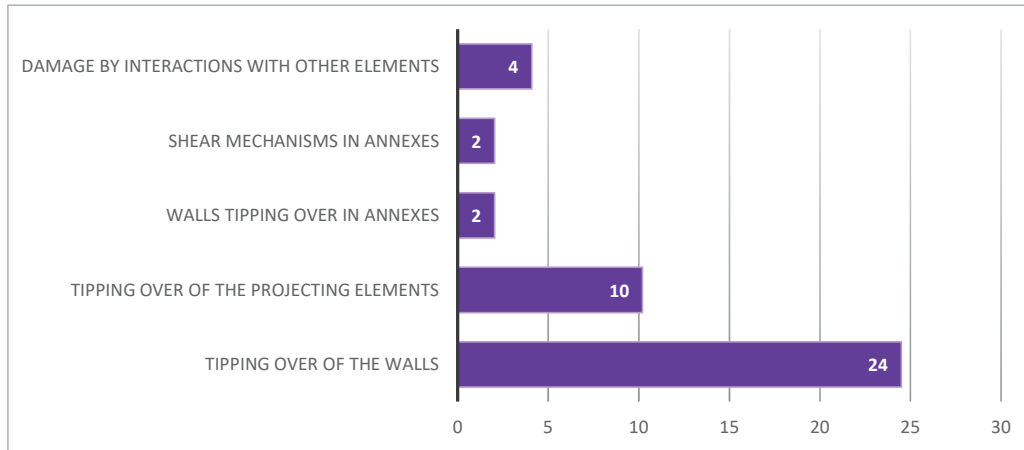

Chart 9. Entrance structurally-corbel: collapse mechanism (%) occurred in Emilia-Romagna crater

Elements covered by compartments, on the other hand, are usually generated by the *infill process* that led the columbarium to close in on itself and to define an element of completion in absence of a pre-existing monumental entrance. We can also find atria or other spaces that allow passage between different enclosures in the presence of doubling of building areas or replacement of the funerary chapel macro-element. Overall, these elements have the same size in plan and elevation as the columbarium in smaller cemeteries, but in the cemeteries of larger cities they emerge both planimetrically and altimetrically with projecting elements or with vaults and domes.

The mechanisms identified for this configuration are:

- Tipping over of the façade. This can tip over the whole façade or just the top part. Typical horizontal hinges in the façade plane and tilted cracks on the sides appear when the mechanism is activated (Fig. 20).



Fig.20. Cemetery of Reggiolo (RE). Ph. Arch. Storchi

- Tipping over of projecting elements. When inserted inside passages they are generally crowning elements with a mainly linear rather than singular development, such as pediments or attics. However, we also find flaming vases and crosses (Fig. 21). Although they represent a very vulnerable element, no damage to these elements was recorded. Nevertheless, the mechanism is included in the abacus of possible kinematic mechanisms, as the presence of these elements was concentrated in the Bologna area where macro-seismic intensities were low. It is assumed, therefore, that the coincidence between the geographical distribution and that of seismic intensity has not led to the activation of this mechanism which is, however, possible.



Fig.21. Cemetery of San Matteo dalla Decima (BO). Ph Arch. Comino

- Hinge formation in arches or lintel damage. In this case, the presence of entrances with arches and an earthquake direction acting in-plane can generate behaviour that is well defined by A-DC form for the triumphal arch (Fig. 22).

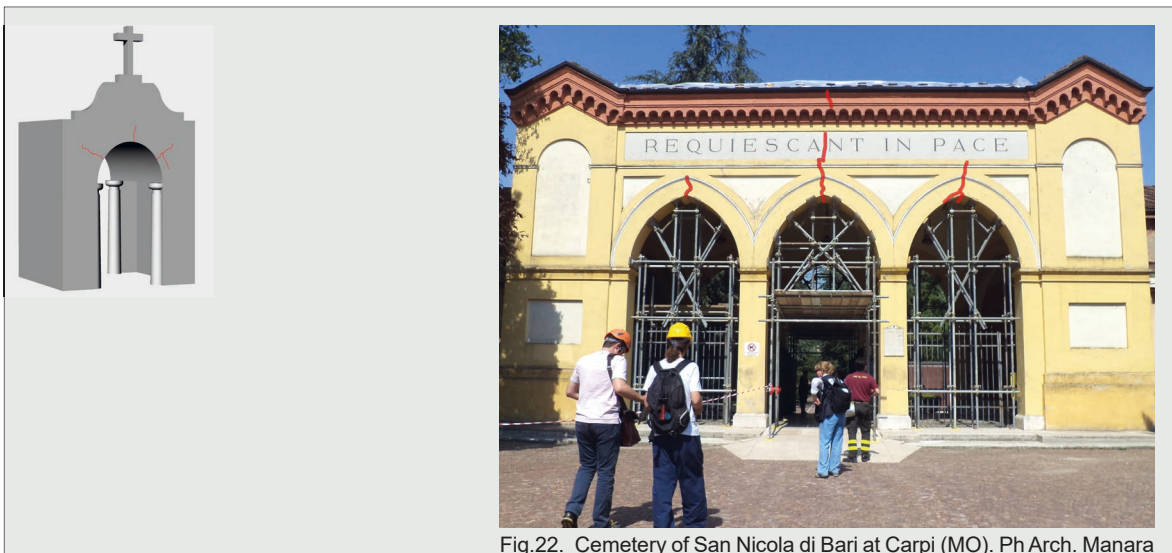

Fig.22. Cemetery of San Nicola di Bari at Carpi (MO). Ph Arch. Manara

- Damage to vaults and floors. Due to the intrinsic nature of the intermediate floors of the cemeteries, made of folio vaults or semi-rigid elements in reinforced slabs or SAP-type, this is one of the most vulnerable elements. Damage has occurred both from local collapses (Fig. 23) and from wall movement.

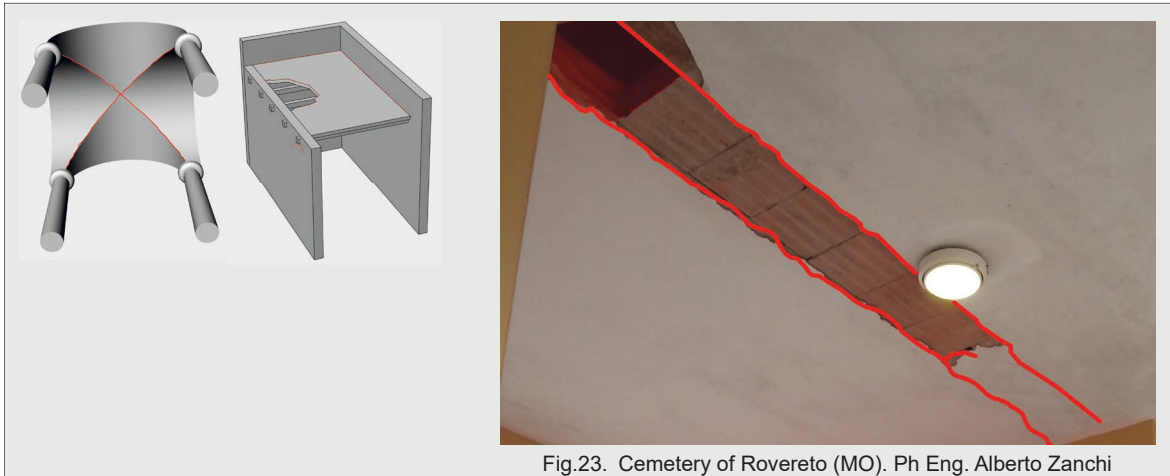

Fig.23. Cemetery of Rovereto (MO). Ph Eng. Alberto Zanchi

- Dome damage. This type of damage is equal to that identified on form A-DC for churches. The parts covered by compartments with dome elements are extensively present when these replace funerary chapels, as in the case of the cemetery of San Cataldo for example (Fig 24) or in that of Finale Emilia, both in the Modena crater area.

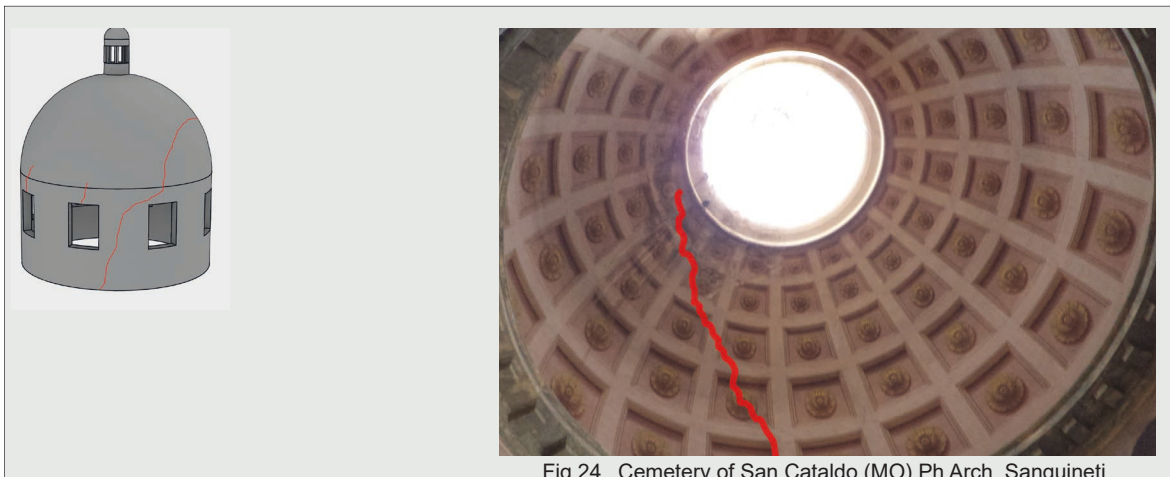

Fig.24. Cemetery of San Cataldo (MO).Ph Arch. Sanguinetti

- Damage due to in-plane actions. This type of damage occurs mainly in the masonry from which the columbarium branches out or which separates the passage from any storerooms and guardhouses located within the element (Fig. 25).

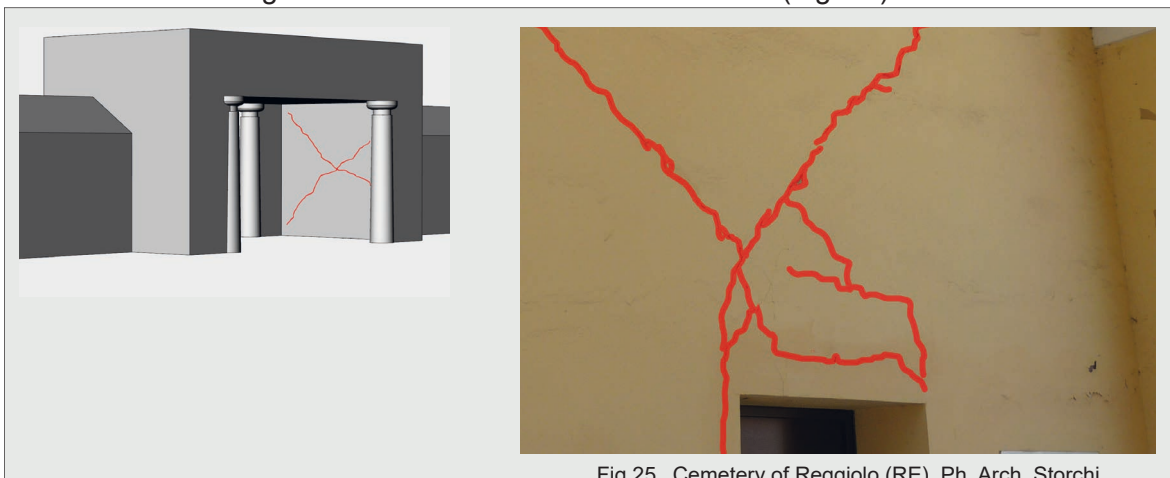

Fig.25. Cemetery of Reggiolo (RE). Ph. Arch. Storchi

- Damage by interaction with other elements. The construction of crossing elements that allow passage between different enclosures or different branches of columbaria, due



to plani-altimetric or constructive irregularities is naturally vulnerable to hammering or interaction between different structures (Fig. 26).

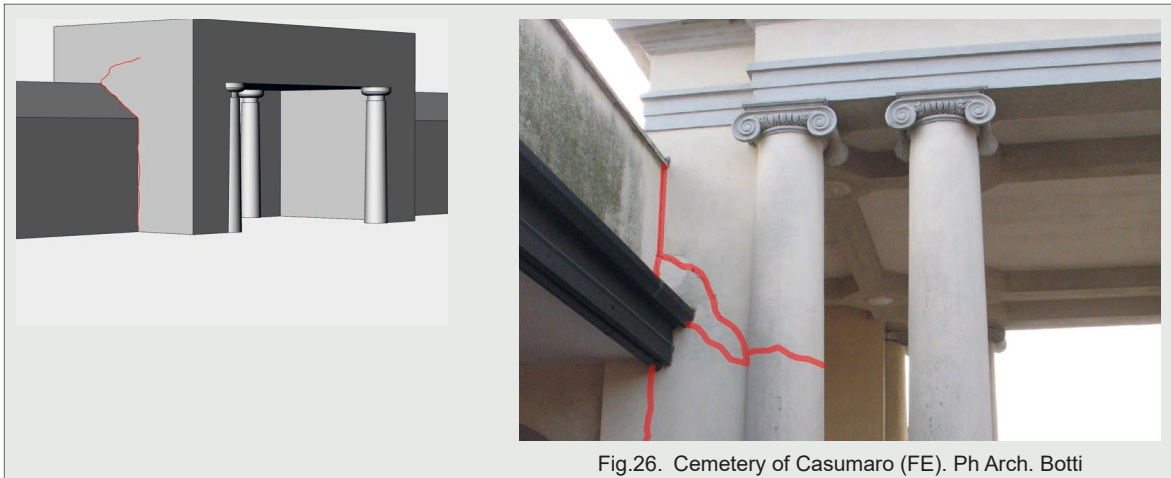

Fig.26. Cemetery of Casumaro (FE). Ph Arch. Botti

The mechanisms of the covered compartment elements all occurred on a fairly recurrent basis (Chart 10).

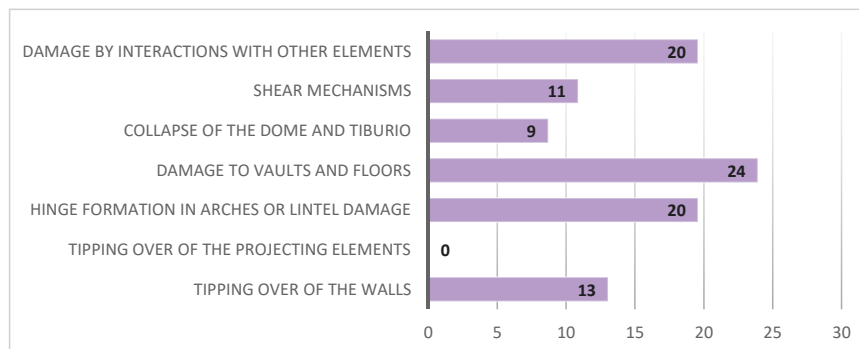

Chart 10. Elements with a covered through compartment: collapse mechanism (%) occurred in Emilia-Romagna crater area.

If we compare the distribution of damage in the case of structural corbel elements and in the case of the covered compartments, we can observe that, while in the first case there is a dominance of wall activation followed by the tipping over of the projections, in the second case, distribution is more homogeneous (Chart 11).

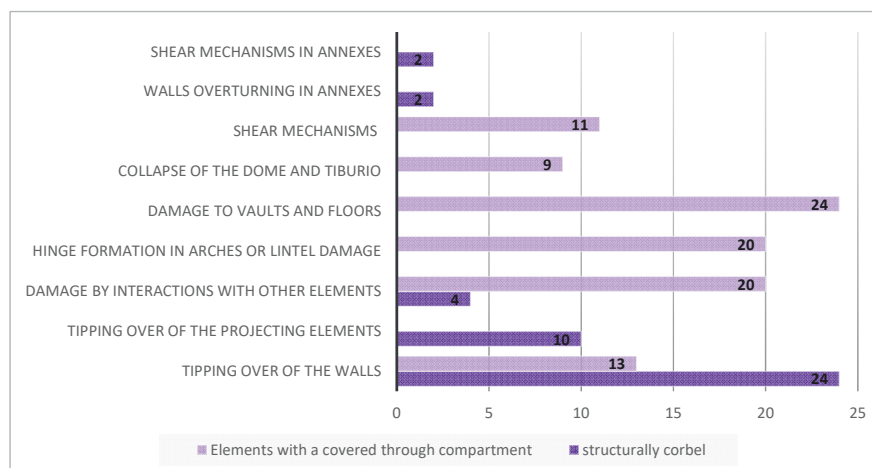

Chart 11. Elements structurally corbel and with a covered through compartment: collapse mechanism (%) occurred in Emilia-Romagna crater area.

- **Columbaria mechanisms**

The columbaria may or may not have a portico. In the particular case of Emilia-Romagna, however, it must be pointed out that, within the crater area, only 2% of the damaged cemeteries show the non-porticoed *variant*. These are the cemeteries of San Donnino (Fig. 27) and San Prospero (Fig. 28), both in the Modena crater area.



Fig.27. Cemetery of San Donnino (MO).



Fig.28. Cemetery of San Prospero (MO).

The non-recurrence of this second configuration made it impossible to identify specific collapse mechanisms. Investigation was only possible later, with the acquisition of additional data from other earthquakes (e.g., the 2016 “Centro Italia” earthquake). On the contrary, the abundance of elements with porticoes led to the identification of several collapse mechanisms:

- Tipping over away from the colonnade. This represents the most dangerous collapse mechanism for the porticoed wings of cemeteries, as the tipping over of a portico also leads to the collapse of the intermediate floors and roofing structures, which fall and damage the structures that house the burial niches (Fig. 29). Often facilitated by the nature of the roofing structures used in the crater area (thrusting and semi-thrusting), it appears with cracks that identify the horizontal hinge and tilted cracks in the cross walls (Fig. 30). The horizontal hinge can be found in the interface between the base and the shaft of the columns, a vulnerable area as these two elements often separate. It can also occur at the height of any tie of vaults, allowing the rotation of only the top part.

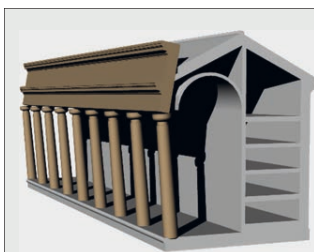

Fig.29. Cemetery of Mirandola (MO).  
Ph Arch. Prati

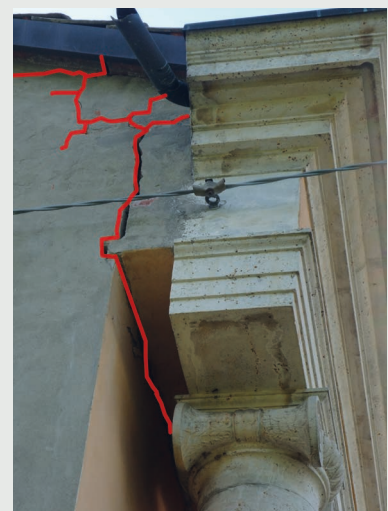
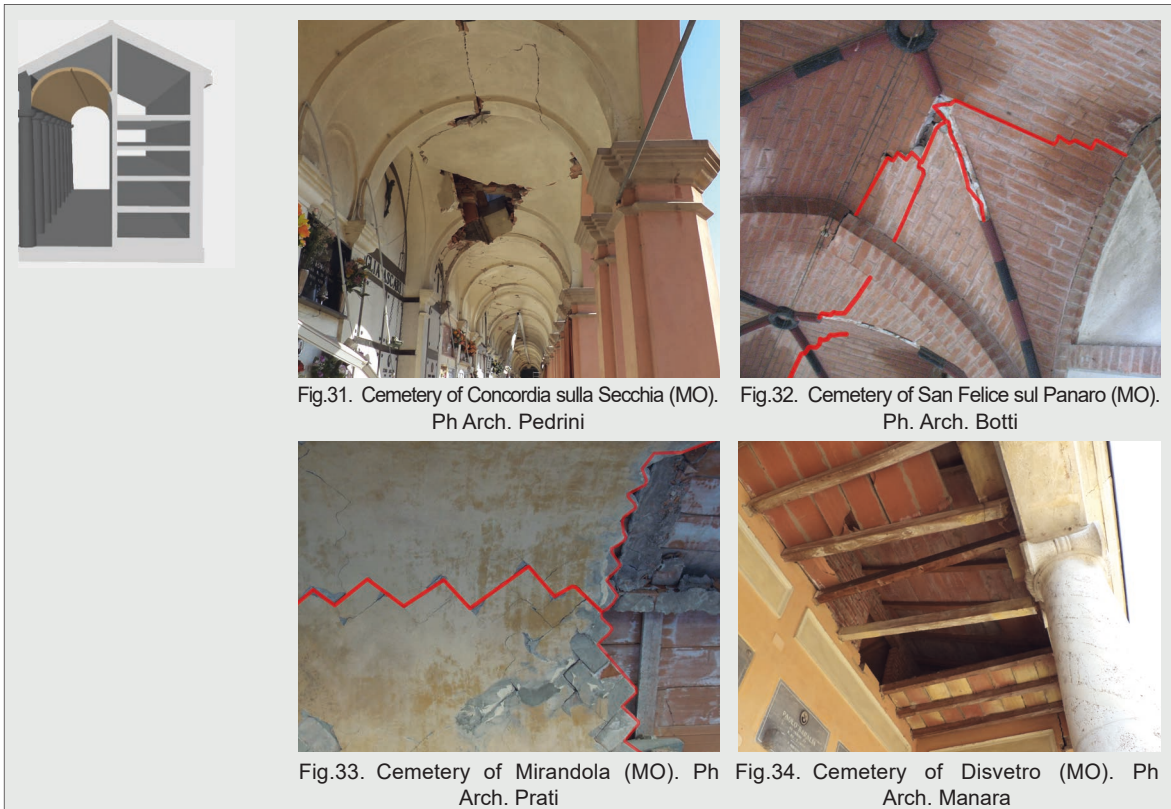
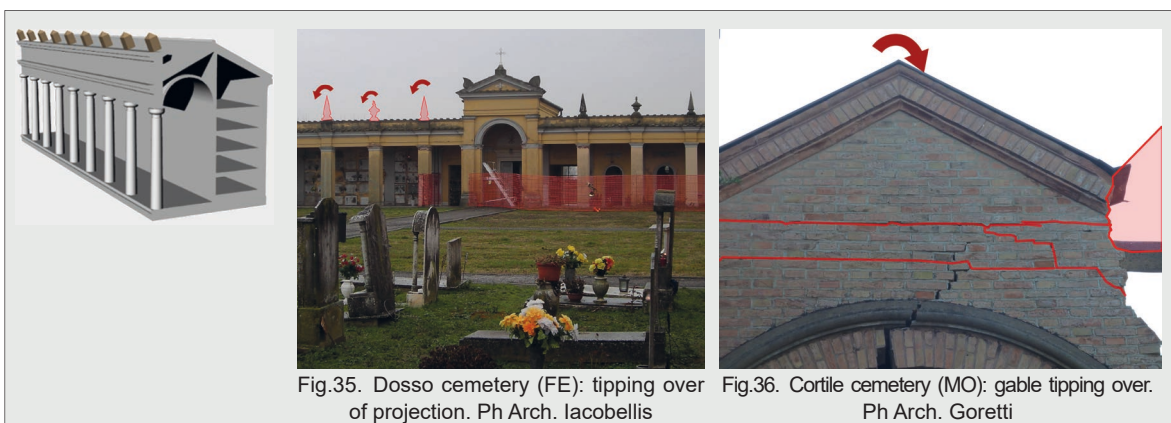

Fig.30. Cemetery of Disvetro (MO).  
Ph Arch. Manara

- Collapse and/or damage to the vaults and floors. A secondary mechanism with respect to that of the portico, generally activated by the rotation of the plinths due to the tipping over of the colonnade or due to local collapse. The development of the cracks is strictly connected to the type of vault or floor, e.g.: parallel cracks in the key and in the impost for barrel vaults, etc. (Figs. 31, 32, 33 and 34).



- Tipping over of the projecting elements away from the floors. Although this does not trigger a structural collapse mechanism, the presence of attic solutions, singular and/or linear architectural elements aimed at hiding the pitches of the roof constitutes a serious element of vulnerability in the structure (Figs. 35 and 36). The tipping over of these elements can take place outwards or inwards, as in the case of the Concordia sulla Secchia Cemetery (Fig. 31).



- Shear damage. The identification of this damage can be tricky. In the presence of visible masonry, generally in the corner areas, it is identified with the typical easily detectable

cross-shaped cracks, the pattern of which is also present in current survey tools. In invisible walls, those that identify the distribution structures between the niches, the situation is more difficult and it is necessary to know in advance how this damage occurs. This type of damage occurs mainly in the presence of a flat ceiling and high beams covering the portico, and can be considered as a sort of shear-type frame. In this case, the columbarium structure should be conceptually understood as a portal structure in which one of the two pillars is made of brick. Although the cemetery structure promotes out-of-plane actions, the presence of mixed structures with columns and brick walls which support concrete-masonry floors with high beams, which architecturally configure coffered ceilings, promotes the development of very dangerous shear effects. In this case, damage due to shear effects appears as horizontal cracks in the thickness of the masonry, the area usually visible, and in inclined cracks in the transverse direction, which is usually invisible or only partly visible, through to the expulsion of the masonry (Fig. 37).

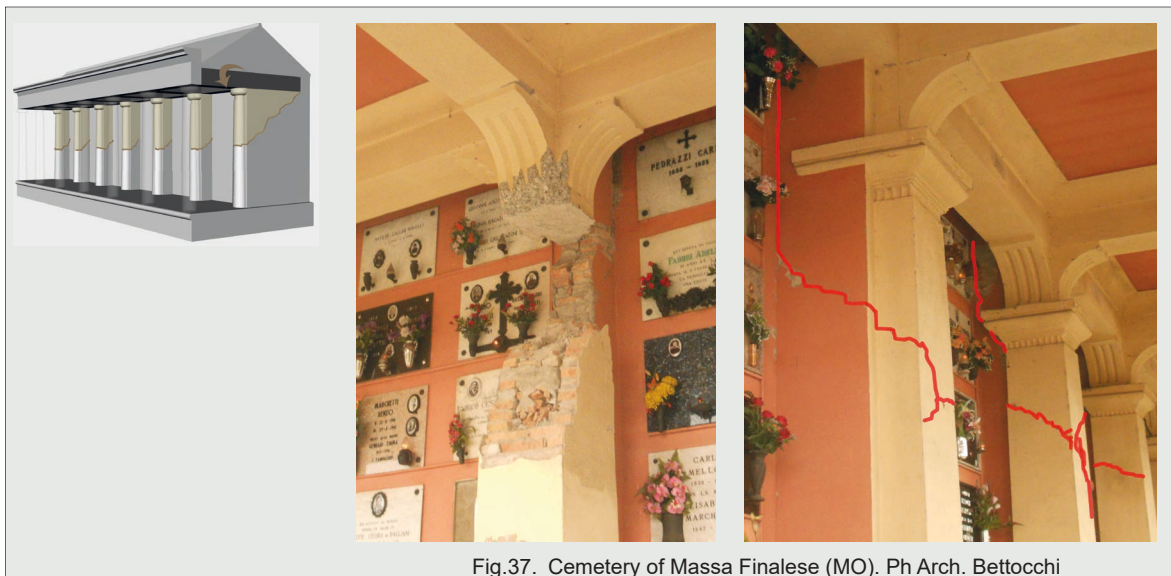

Fig.37. Cemetery of Massa Finalese (MO). Ph Arch. Bettocchi

- Compression of slender elements. The shocks of May 20 and 29, 2012 also involved a strong vertical seismic action. This resulted, in the case of cemeteries, in considerable damage due to the effects of compression detectable in portico colonnades. This is typically expressed by vertical or sub-vertical cracks and, in the case of reinforced concrete pillars and columns, often the expulsion of the cladding or of the concrete covering layer (Figs. 38 and 39).

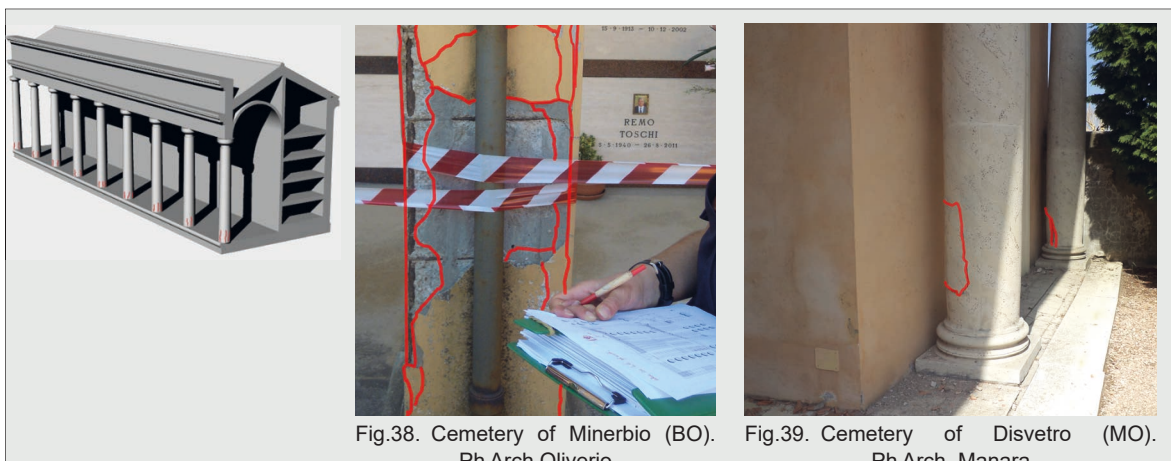

Fig.38. Cemetery of Minerbio (BO).  
Ph Arch Oliverio

Fig.39. Cemetery of Disvetro (MO).  
Ph Arch. Manara

- Damage to arches and lintels. The porticoed columbarium structure is inherently vulnerable to damage to arches and lintels. In the crater area, these were damaged in the most cases. The cracks can be of varying nature and result from shear or bending effects, or even from the presence of a small support element for the beams. We witness the formation of hinges in the arches (Figs. 40 and 41) or vertical or horizontal cracks in the lintels (Figs. 42 and 43).



- Differential movement damage. Occasionally, the morphology of porticoed columbaria represented by a solid and rigid built area, i.e., the niches, plus a more flexible one, that of the portico linked to roof structure, suffered damage at the interface between the two structures. These, moving differently during an earthquake, generated horizontal cracks at the connection point between the two elements (Fig. 44).

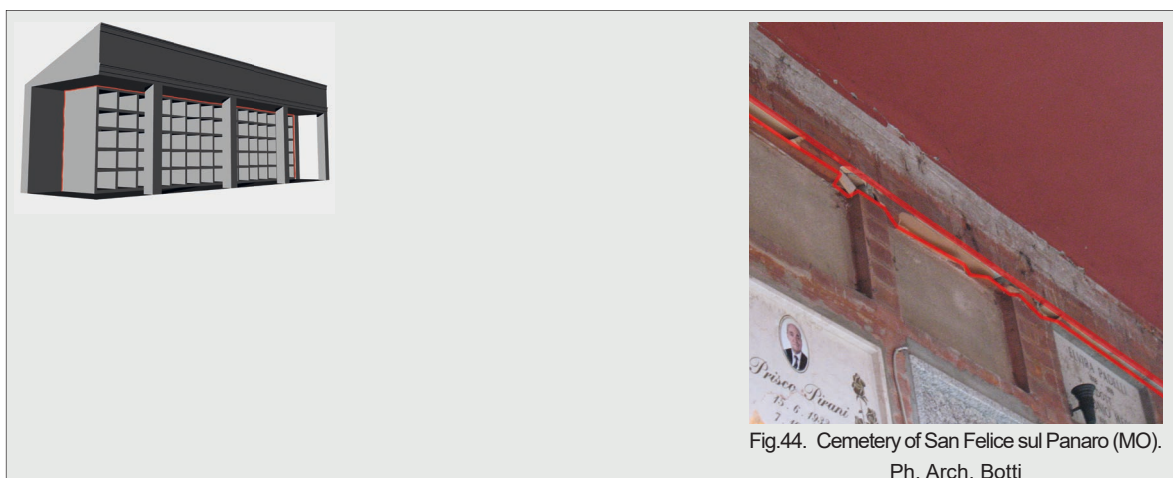

- Tipping over of the rear wall. Although the portico area is the most vulnerable, the rear wall also sometimes suffered out-of-plane action. The tipping over is explained by the lack of cross-connecting walls. In columbaria, this can occur for the whole height of the

element in the case of continuous structures in reinforced concrete, or only in the end part in masonry structures with cross walls that are often interrupted in the roof space as a result of changes in the renovations or construction weaknesses. The presence of slender masonry without cross retainers is an element of vulnerability that can lead to the activation of the mechanism (Fig. 45).



Fig.45. Cemetery of Concordia sulla Secchia (MO). Ph Arch. Pedrini

- Damage due to irregularities in construction and shape. Cemetery structures are unfinished architectures. It is often possible to identify columbaria that are organised with a view to further extension within the perimeters. This feature does not, however, ensure perfect connection of the sides and the heterogeneous set of buildings that develop as a result of successive additions with different techniques is conducive to the formation of cracks in the connection points, within the different arms (Fig. 46) and in the corners (Fig. 47). Cracks are often visible inside the cemetery but also outside, along the rear wall.

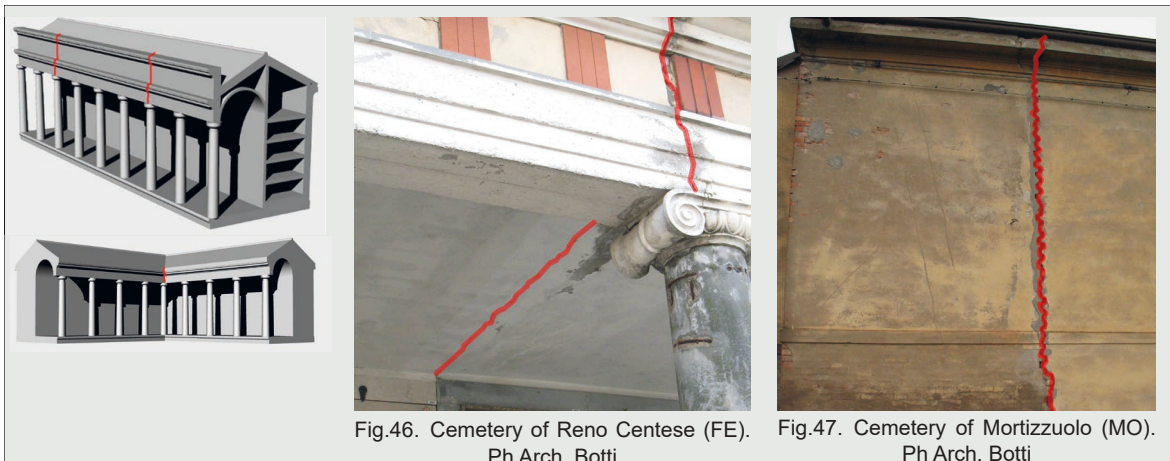

Fig.46. Cemetery of Reno Centese (FE).  
Ph Arch. Botti

Fig.47. Cemetery of Mortizzuolo (MO).  
Ph Arch. Botti

- Damage due to interaction of the structures. The heterogeneous set of buildings that develop as a result of successive additions is conducive also to triggering interaction mechanisms in the structure. These occur between the different macro-elements connected to each other (Fig. 48). However, although recent construction is not usually directly connected to historic structures, there are some cases of interconnection with beams or roof structures of new columbarium elements that have generated several cracks (Fig 49). Even though these structures belong to the same macro-element conceptually, their status as a “new element” identifies them as a different structure from that of the historic columbaria.



- Damage due to bottom subsidence. In the case of the 2012 Emilia earthquake, this was also connected to the phenomenon of liquefaction that occurred in some cemeteries. Due to the movement of the ground, there was localised subsidence of the columbaria. The cracks are visible inside the cemetery (Fig. 50) but also outside, along the rear wall.

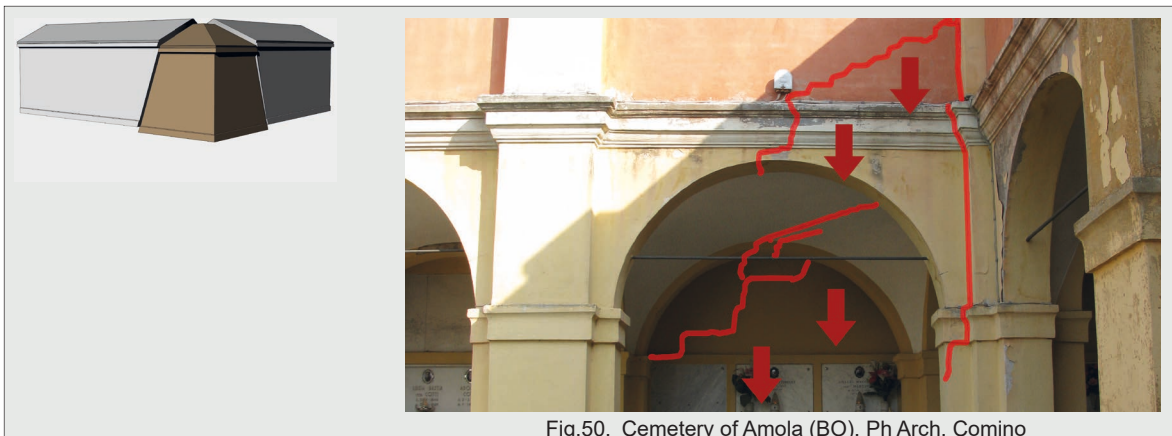

- Damage due to the concentration of seismic strength at extremities. Its nature as a growing building via juxtapositions and changes, makes the cemetery similar to an urban area, where different buildings or structural units are combined over time. As in the case of urban aggregates, concentrations of seismic forces occurred in the edges, damaging them. Unlike damage due to irregularities in construction or shape, this is a global collapse and not a local one, because it involves the whole element. In the case of the cemetery of Padulle, in the Bologna crater area, for example, the seismic action was concentrated at the interface between two branches, built at different times, causing a global mechanism of tipping over of the more recent branch (Fig. 51).

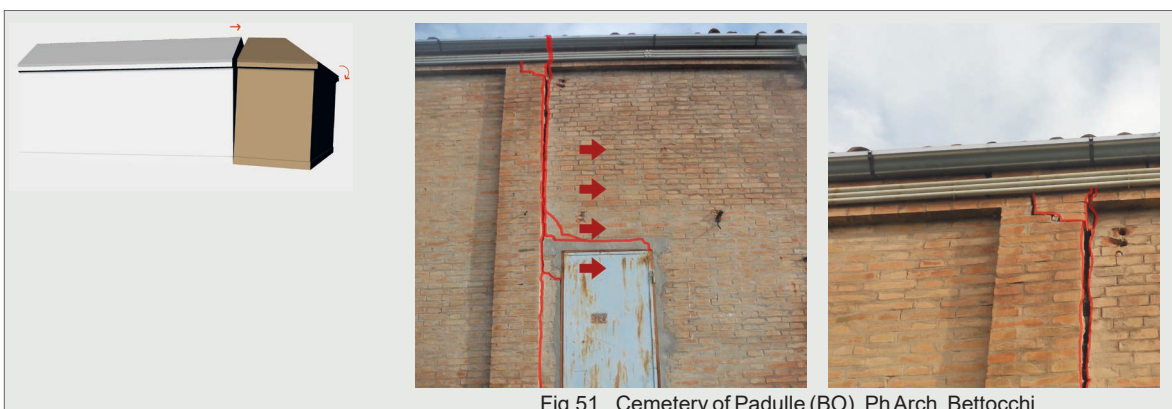

As shown in Chart 12, damage to columbaria in cemeteries occurred with considerable variability related to the intensity of the earthquake in the area and the construction techniques used.

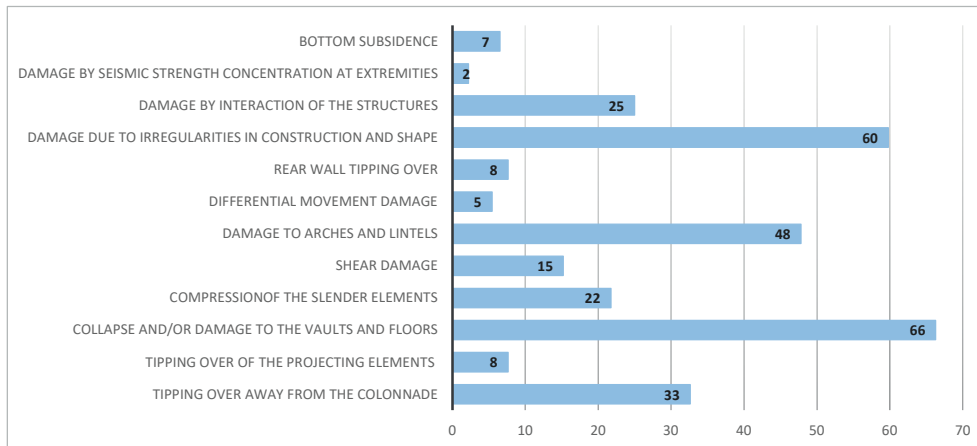

Chart 12. Columbaria: collapse mechanism (%) occurred in Emilia-Romagna crater area.

• **Family tomb mechanisms**

The family tombs included in the damage forms are relatively rare. This is primarily due to their quite recent construction, which excludes them from the damage survey with cultural heritage forms: of the 99 cemeteries analysed, only 34 contained historic family tombs. Secondly, the intrinsic nature of the constructions, usually low box-like buildings with almost no openings, qualifies them as low vulnerability elements and the damage observed on them is consequently limited. Lastly, it should be considered that the extension of cemeteries using family tombs is rarely applied in the crater area, where they are classified more as singular tombs that occasionally fill the burial field than as extensive elements of cemetery construction, significantly reducing the possibility of observing their behaviour in aggregate form.

The mechanisms identified in the emilian crater therefore are:

- The tipping over of walls. In some cases, tipping mechanisms were activated (Fig. 52) but without exceeding level 1 (mild damage) on the damage scale.

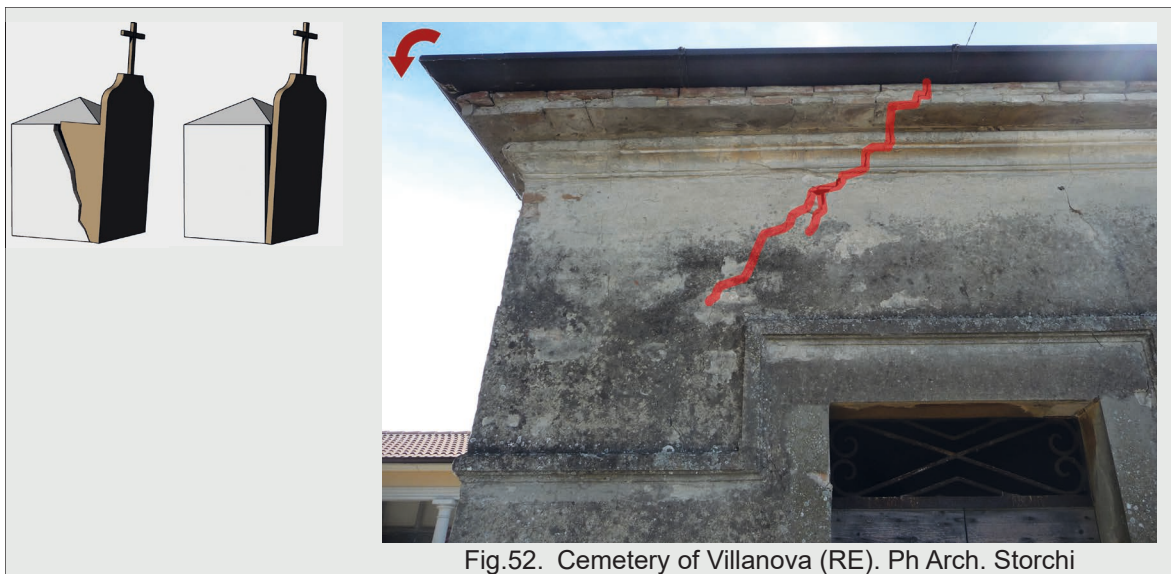
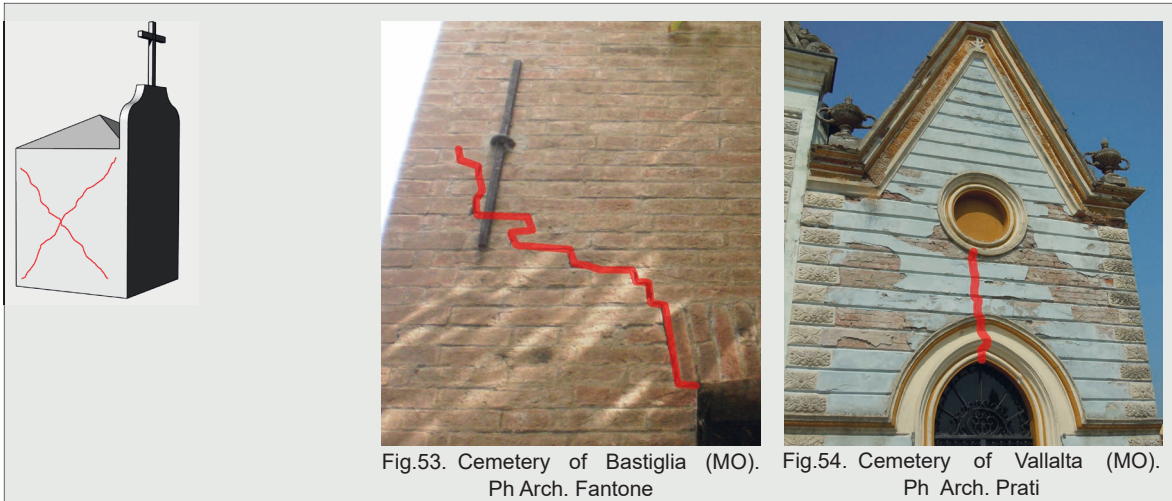

Fig.52. Cemetery of Villanova (RE). Ph Arch. Storchi

- Damage due to in-plane action. Similarly to the damage caused by the tipping over of walls, any in-plane action was of mild intensity (Figs.53 and 54).





- The tipping over of projecting elements. Family tombs are based, on one hand, on the archetypal “house”, generating the construction of simple box-like elements similar to residential buildings. On the other hand, they are sometimes ennobled using the characteristics of church buildings. This had resulted in elements that often have screen-faces (albeit small) or projecting elements that are particularly vulnerable. These were also damaged in the 2012 earthquake, sometimes severely (Fig. 55).



- Interaction Damage. In aggregate form, construction or plani-altimetric differences can generate interaction damage on elements (Fig. 56).

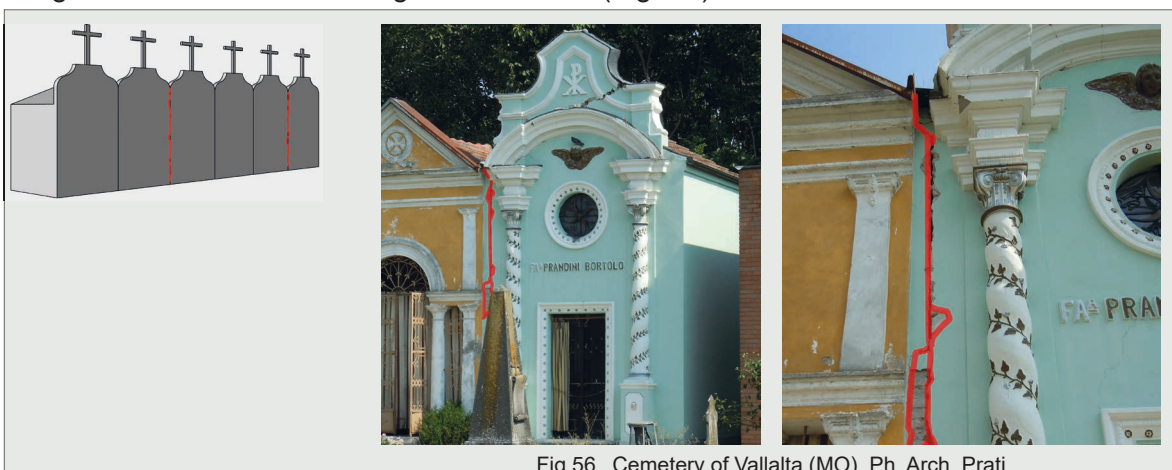

Damages suffered by the family tomb macro-elements in 2012 were infrequent, in keeping with both the element's vulnerability and its territorial spread, as shown in chart 13.

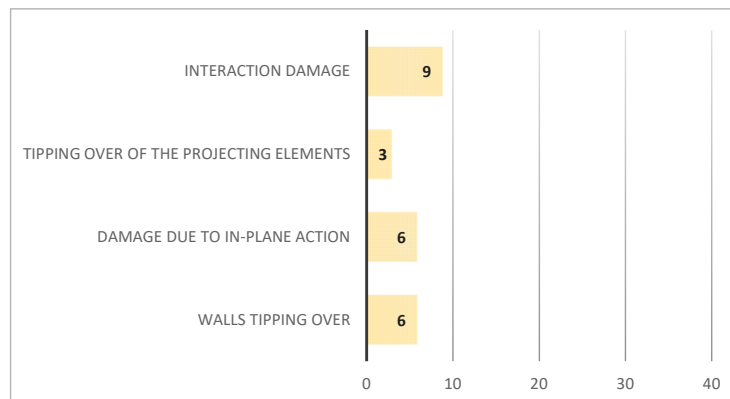

Chart 13. Family tombs: collapse mechanism (%) occurred in Emilia-Romagna crater area.

- **Funerary chapel mechanisms**

Funerary chapels are effectively churches and observe their architectural-structural codification. The collapse mechanisms identifiable on these elements are therefore the same as those already identified by form A-DC for churches, which is now part of our legislation. In the case of the 2012 earthquake-damaged cemeteries, out of 99 cemeteries, 83 contained this macro-element in either aggregate form or as a separate element within the enclosure. The damages found on them are:

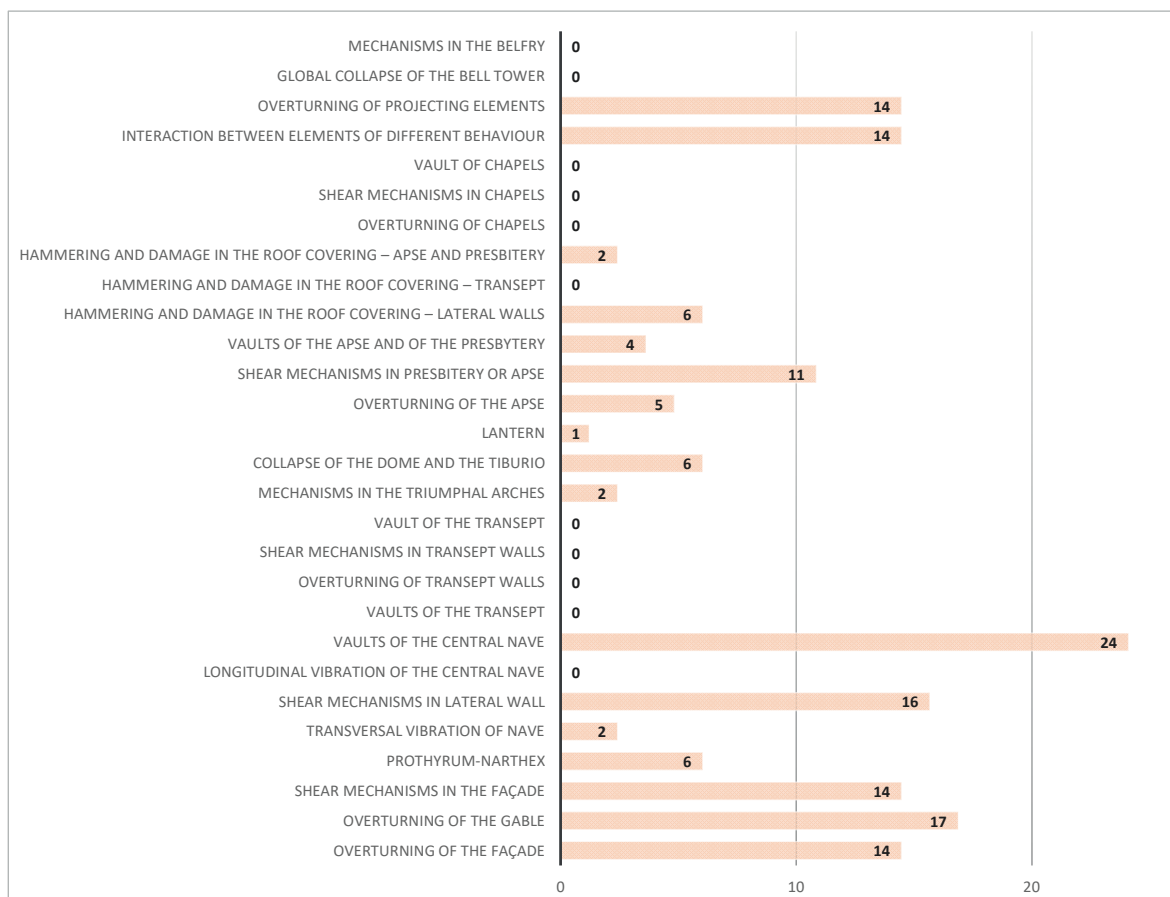

Chart 14. Chapels: collapse mechanism (%) occurred in Emilia-Romagna crater area.

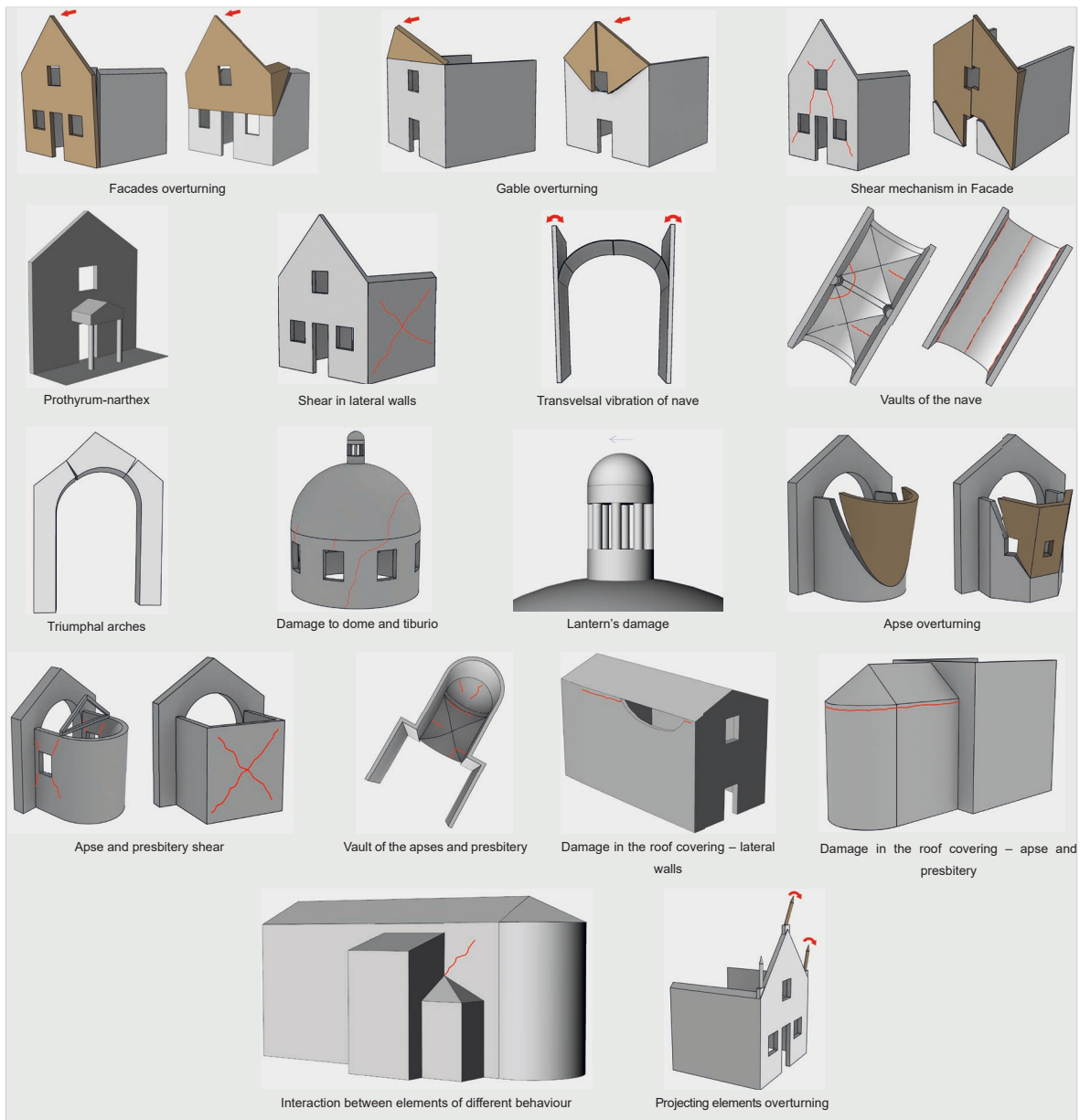

Fig.57. Collapse mechanisms of Form A-DC activated in funerary chapel in Emilia earthquake.

• **Definition of recurring collapse mechanisms**

The mechanisms identified in the cemeteries inside the Emilia crater have led to the definition of an abacus of all the mechanisms occurring within the area. These are extremely variable and not all of them seem to be due to characteristics typical of the investigation type, i.e., cemeteries, but rather related, in some cases, to factors of weakness of a specific cemetery due to its own construction history. The damage survey forms, especially when dealing with complex buildings like cemeteries, take into account only frequently recurring mechanisms<sup>11</sup>, leaving further space to be filled in to allow consideration of possible mechanisms of a specific nature<sup>12</sup>. These, if present, can be captured through fields indicated as “other”, but a preliminary case list is not defined.

.....  
 11 Recurrence: each of the cases in which a given phenomenon occurs.

12 B-DP form allows for this division.

Previous charts have shown the percentage frequency with which each mechanism identified occurred in the 2012 earthquake. Taking into account the actual vulnerability of each macro-element and the location of the cemeteries mainly within areas with low or high macro-seismic intensity, this allows the identification of mechanisms with such recurrence as to be considered as typical collapse mechanisms of the cemetery structure. The higher or lower frequency of a collapse mechanism can be considered as a sign of a typical collapse mechanism or of a singular collapse mechanism of a structure. Regarding macro-seismic intensity, it should be noted that, given the medium-low macro-seismic intensity for most of the cemeteries, even frequencies of around 10% can be considered valid in relation to the element's vulnerability.

The frequencies are assessed below for the identification of the recurrent collapse mechanisms for each macro element:

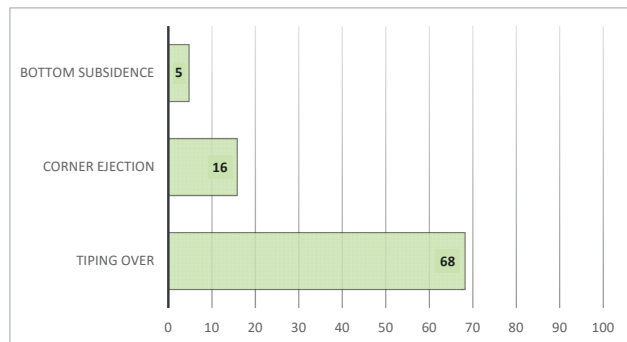
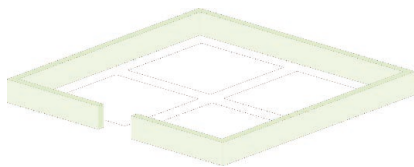

For the surrounding wall macro-element, the mechanism with the highest frequency is the tipping over of the wall, while that with the lowest frequency is the bottom subsidence. The corner ejection mechanism is not particularly frequent compared to the tipping over of the wall but it would be more frequent if it were considered in relation only to cemeteries where the surrounding walls have corner configurations. Therefore, bottom subsidence is an ever-possible vulnerability, being related to the movement of the ground during the earthquake and not to the macro-element itself. Due to this nature, the Ad-DC form has preferred to don't take into account this mechanisms. B-DP form, instead, has preferred to acquire it. In the cemetery case it was decided to follow the A-DC form line and remove it from the typical mechanisms.

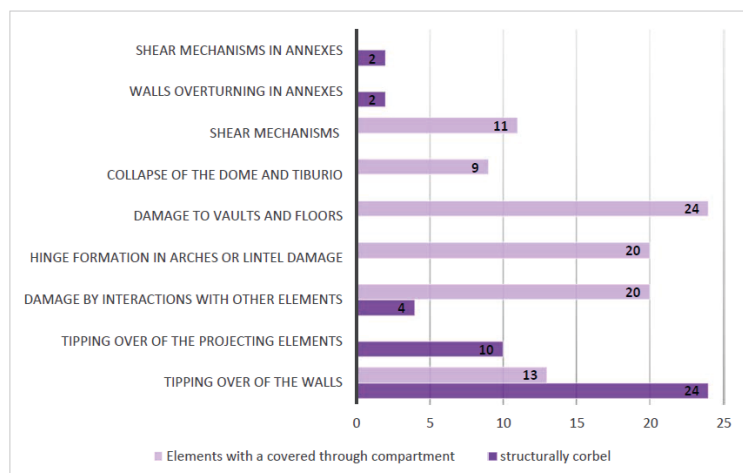
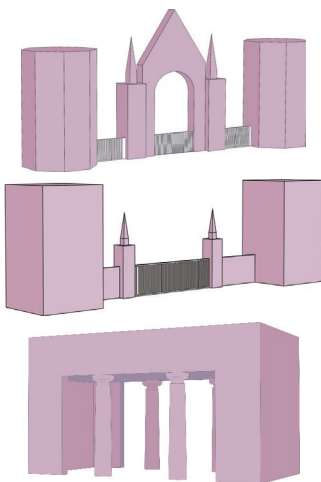

For the macro-element crossing elements, almost all the mechanisms activated have, at least for one of the two configurations, occurred frequently with the exception of damage

to annexes in the corbel structural configuration (2%). These mechanisms are therefore identified as typical mechanisms. As regards damage to the annexes, considering that their presence in a corbel-structural configuration accounts for 12% of the total, their frequency, in relation to the real occurrence of the elements, rises to 33%, qualifying them as typical damage. In conclusion, also for crossing elements, all the collapse mechanisms are considered as typical recurrent mechanisms.

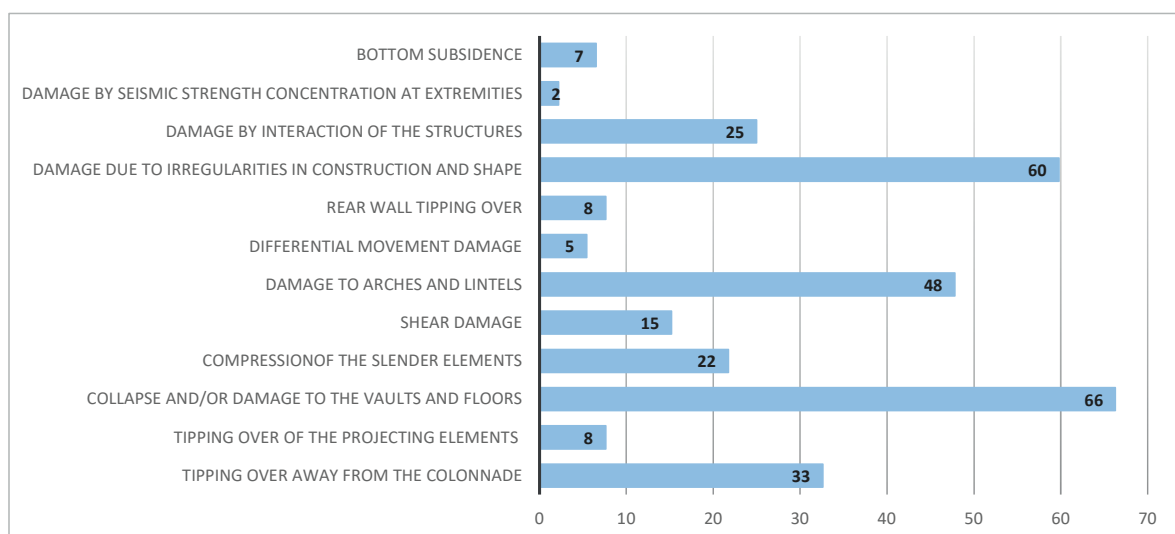
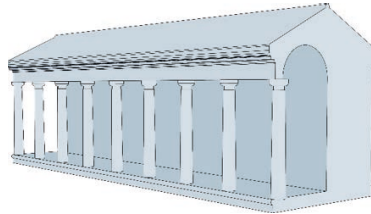

In the case of the columbarium macro-element, considering the abovementioned frequencies, the tipping over of the portico, damage to vaults and floors due to plane deformation or local collapse, the compression of slender elements, shear mechanisms, damage to arches and lintels, damage due to irregularities in construction and shape and to interaction with other macro-elements can certainly be considered as typical vulnerabilities. The tipping over of projecting elements has a frequency of 8%, but the presence of these elements on the columbarium relates to around 47% of the cemeteries under investigation, increasing its frequency to 15%. Considering the vulnerability of these elements, this mechanism can also be considered typical. With regard to damage by differential movement, the tipping over of the rear wall and concentration of seismic action at the edges, their frequency is 5%, 8% and 3% respectively. To date, it seems possible to qualify these elements as non-recurring mechanisms. However, due to the nature of some of these mechanisms, such as differential movement damage, related to cemetery construction techniques, their exclusion may be reassessed in the future in consideration of new survey samples which, being made with different materials and construction techniques, may see a higher incidence of certain types of damage.

Lastly, the frequency of bottom subsidence, equal to 7%, low, is considered, similarly to the surrounding wall, as excluded among the typical recurrent mechanisms.

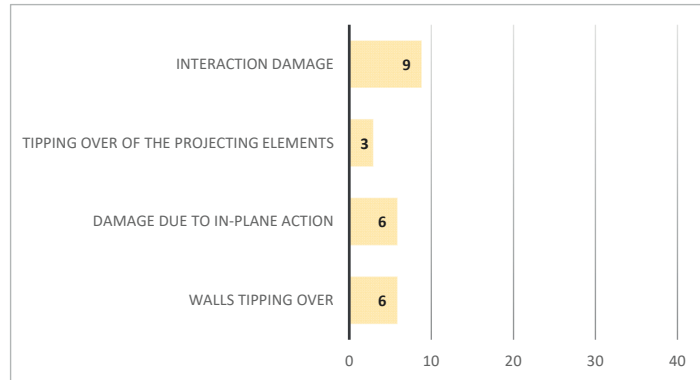
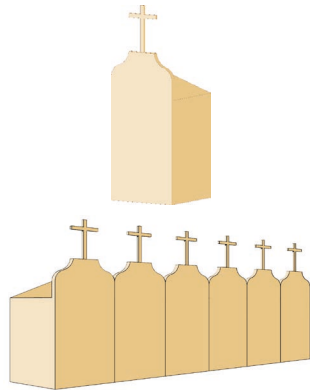

In relation to the family tomb macro-element, the mechanisms activated are all below the 10% threshold. However, considering the low vulnerability of this element and the low use of this element in the survey area, all mechanisms are considered, to date, as typical recurrent mechanisms.

Once again, further studies with survey samples in which the element has been more prevalent may modify this initial list.

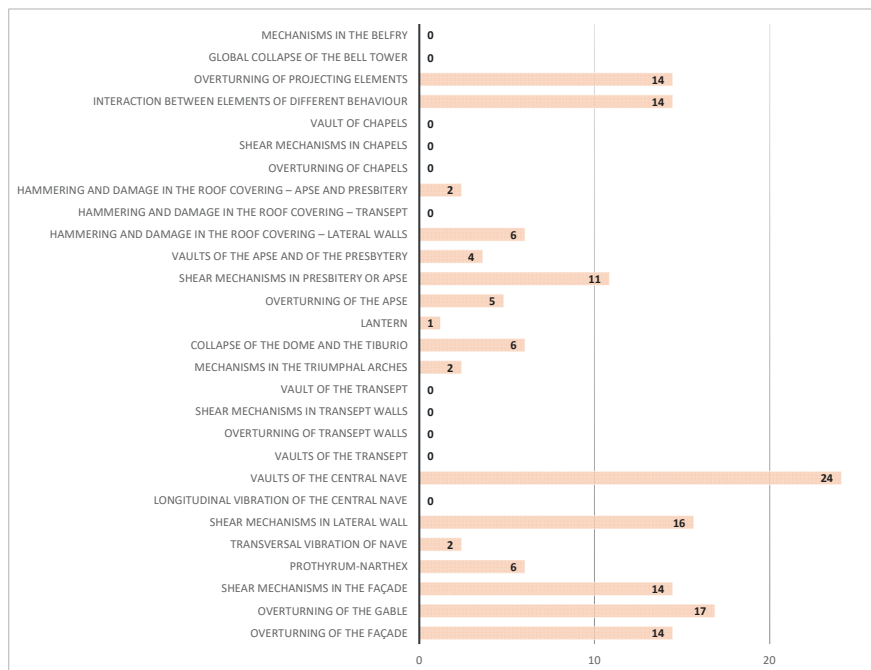
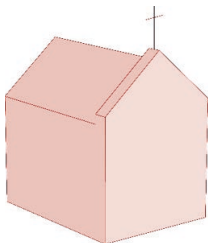

Regarding the funerary chapel macro-element, the mechanisms already identified for church buildings are not to be considered as subject to review. The frequency with which these occurred is not intended as an indicator for the identification of typical recurring collapse mechanisms, as the 28 mechanisms on form A-DC are already typical recurring damage mechanisms for churches. The above graph is used to identify the already validated mechanisms that can be eliminated from the cemetery form and included, if necessary, as damages that recur only occasionally. The presence of elements such as transepts, belfries, aisles and chapels, is not typical of funerary chapels and the absence of damage in the chart is linked to the absence of the element, not to its construction qualities. All mechanisms are therefore typical recurrences, but the cemetery form will not consider the mechanisms inherent in the above-mentioned elements.

In conclusion, the collapse mechanisms to be included in the damage survey form for cemetery structures in relation to what has been identified by the following analyses are:

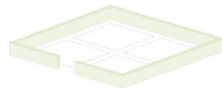

### Surrounding wall

- out-of-plane tipping over
- corner ejection

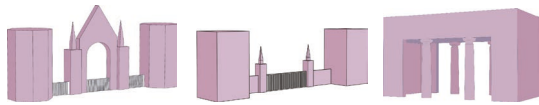

### Crossing elements

- Tipping over of the walls
- Tipping over of the projecting elements
- Damage by interactions with other elements
- Hinge formation in arches or lintel damage
- Damage to vaults and floors
- Collapse of the dome and tiburio
- Shear mechanisms
- Walls tipping over in annexes
- Shear mechanisms in annexes

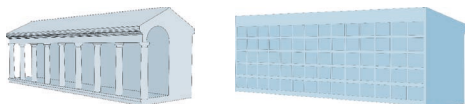

### Columbaria

- tipping over of the portico
- tipping over of projecting elements
- damage to vaults and floors due to plane deformation or local collapse
- compression of slender elements
- shear mechanisms
- damage to arches and lintels
- damage due to irregularities in construction and shape
- damage due to interaction with other macro-elements

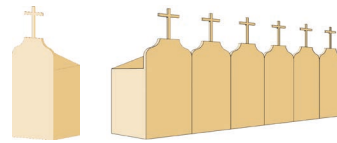

### Family tomb

- Walls tipping over
- Damage due to in-plane action
- Tipping over of the projecting elements
- Interaction Damage

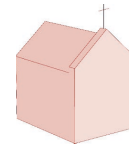

### Funeral chapels

- tipping over of the façade
- tipping over of the gable
- shear mechanisms in the façade
- prothyrum-narthex
- transversal vibration of nave
- shear mechanisms in lateral wall
- vaults of the central nave
- mechanisms in the triumphal arches
- collapse of the dome and the tiburio
- lantern
- tipping over of the apse
- shear mechanisms in presbitery or apse
- vaults of the apse and of the presbitery
- hammering and damage in the roof covering – lateral walls
- hammering and damage in the roof covering – apse and presbitery
- interaction between elements of different behaviour
- tipping over of projecting elements

## 4.5. From repair cost to parametric cost for resource allocation

The identification of the cost required for reconstruction is one of the main purposes of the cultural heritage damage survey. Obviously, this is a rough estimate that must allow for an initial cost assessment paid for by government agencies and is aimed at quantifying the resources that will have to be found. It is clear that the intention is to reach an overall estimate as close as possible to reality, while being aware that the complex nature of each individual intervention can only be assessed during the drafting of the final project as well as during the construction phase. In fact, the resources shifting within the OOPP and BBCC program can be easily achieved through the Annual Implementation Plans, while finding additional resources following an incorrect initial estimate is more challenging. It is related to uncontrollable factors such as donations, the presence of insurance on assets or political stability. A more accurate estimate, therefore, ensures that the greatest number of buildings can be funded. On the contrary, inaccurate estimates lead to a lack of economic availability for other interventions in the immediate future, due to the inevitable shifting of resources to priority interventions, such as cemeteries. These interventions will be able to access funding only after new resources have been found.

In the 2012 earthquake in Emilia, cemeteries represented one of the main critical issues due to an inaccurate initial economic estimate. This was, on one hand, undoubtedly related to difficulties in filling in the damage forms. Expressing incorrect damage indexes did not allow for identification of the correct parametric cost. On the other hand, the costs were unsuitable for the evaluation of cemetery buildings. The cost of each intervention is assigned on the basis of pre-set standard operations. The value of these operations changes in relation to the damage index both for reinforcement and restoration projects. The operations to be taken into account, however, were identified and estimated on the basis of the interventions that can be carried out on churches and buildings, without taking into account the particular additional costs typical of the cemetery function. And it is precisely these unavoidable costs that affect intervention in cemetery construction. Perhaps the most obvious example is the cost necessary for the displacement, temporary housing and relocation of the coffins removed from the columbarium during work on the site.

The Agency, which examined each individual project submitted, estimated that just € 500 are needed to move a coffin to another place and that the same amount is needed for rehousing it in its niche<sup>13</sup>. This means that it costs just over 1000 €/coffin, without considering the rental of temporary housing to keep the remains safe. In most of the destroyed wings, this figure can reach up to € 100,000 for the single displacement of the coffins.

All this generated a number of economic difficulties. Comparing the economic estimates made by the UCRR between 2012 and 2013 and what was actually envisaged in the OOPP and BBCC program, the result showed that only one third of the cemeteries damaged had been correctly estimated (Charts 15 and 16). It should be noted that the result of this

.....  
<sup>13</sup> The estimate was reported during talks organised by the Agency entitled “*Conoscenza e gestione degli interventi di ricostruzione del patrimonio culturale colpito dal sisma Emilia-Romagna 2012. I progettisti raccontano*” held in Ferrara on 19-20 september 2019.



assessment was obtained in consideration of a tolerance of 20% in the estimate. Minimum discrepancies are considered usual if not normal in this type of estimate.

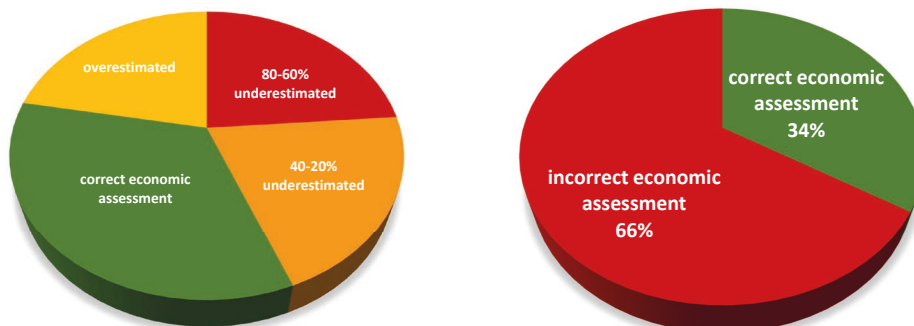

Chart 15-16. Percentage of incorrect assessment.

Considering, therefore, that a damage survey form must be able to provide a greater correspondence not only of structural order but also of an economic nature, a reassessment of the economic parameters to associate to the damage indexes was also performed. It was carried out using economic parameters from projects approved by the Agency for which the grant was formally approved in relation to a specific project. Although the OOPP and BBCC program amounts and grants awarded are published online<sup>14</sup>, the data resulting from the calculations of individual projects are sensitive data that can be viewed only on request. Due to access restrictions caused initially by Covid and then by the smart-working duties of public institutions, it has been possible to find an extremely small number of economic data on single projects on which to carry out statistical analysis. These, variously distributed across the damage classes, were used to identify the weight on the total of the structural, architectural and restoration interventions for each class defined by the regulation. We report below the costs and the percentage weights identified both for the intervention envisaged as a whole and divided by categories of work. Two categories are identified, similarly to that already done for the current damage forms (Fig. 58).

<b>A<sub>22</sub> - DESCRIZIONE E STIMA SOMMARIA DELLE OPERE NECESSARIE</b>	
<b>A<sub>22.1</sub> - Descrizione opere di ripristino strutturale (nuovi danni e danni pregressi aggravati)</b>	
.....	
.....	
<b>STIMA DEL COSTO PER IL RIPRISTINO STRUTTURALE</b>	
€	_ _    _ _    _ _    _ _   ,00
<b>A<sub>22.2</sub> - Descrizione opere di finitura, impiantistica e miglioramento sismico collegate</b>	
.....	
.....	
<b>STIMA DEL COSTO OPERE FINITURA IMPIANTISTICA E MIGLIORAMENTO SISMICO</b>	
€	_ _    _ _    _ _    _ _   ,00
<b>A<sub>22.3</sub> - Descrizione opere di pronto intervento (eventualmente indicare anche il costo del P.I. "a finire")</b>	
.....	
.....	
<b>STIMA DEL COSTO OPERE DI PRONTO INTERVENTO</b>	
€	_ _    _ _    _ _    _ _   ,00

Fig.58. Example of a breakdown of the economic assessment expressed in form A-DC by its different components.

.....  
 14 <https://openricostruzione.regione.emilia-romagna.it/>

Unlike the latter, however, these are divided into structural and architectural/restoration operations. On the existing forms, the distinction is made between consolidation interventions and completion, plant engineering and seismic improvement interventions. In this way, the structural works are divided into two distinct categories, where importance and priority are given to consolidation works over seismic improvement works. This distinction cannot be maintained today. The evident seismic nature of the Italian territory has caused the administrations to lean towards an increasingly significant effort towards seismic improvement for the transmission of our heritage to future generations. From this point of view, the works have been divided into structural and architectural/restoration categories, including seismic improvement within the first category. The assessment of the first-aid works borrowed from the appropriate calculation modules already prepared will also be added.

As the data of the projects are of a sensitive nature, the name of the cemeteries analysed will be replaced here by progressive numbering. Furthermore, here (Tab. 1) we report only the costs of the operations, i.e., with no technical charges and expenses. This choice has a double motivation. First of all, this makes it harder to trace back the costs to the cemeteries, safeguarding data sensitivity. Secondly, this distinction makes it possible to understand more precisely the percentage weight of the two categories on the total works.

Damage class	Cemetery	General cost of intervention	Structural cost	%	Architectural cost	%
4	CEMETERY 1	1 290 659.08 €	803 681.00 €	62	486 978.08 €	38
3	CEMETERY 2	717 525.51 €	524 202.15 €	73	193 323.36 €	27
3	CEMETERY 3	3 065 138.79 €	1 788 895.41 €	58	1 276 243.38 €	42
2	CEMETERY 4	153 609.42 €	131 979.49 €	86	21 629.93 €	14
2	CEMETERY 5	2 708 004.21 €	2 316 920.98 €	86	391 083.23 €	14
1	CEMETERY 6	142 474.91 €	116 040.50 €	81	26 434.41 €	19
1	CEMETERY 7	257 698.60 €	190 674.51 €	74	67 024.09 €	26

Tab.1. Ratio between architectural e structural cost in the cemetery analysed.

In the case of the severe damage range, from 3 to 4 on the specific scale, it can be noted how the weight of the two different categories of work changes slightly depending on the greater or lesser monumental nature of the cemetery. In fact, Cemetery 1 and Cemetery 3, both monumental cemeteries, show a ratio of 60% for structural works and 40% for architectural works. In the case of Cemetery 2, however, the ratio shifts towards the structural category, which represents 70% of the works required. This figure is in line with the related works because, as the monumentality of the cemetery increases, the number of restorations works related to frescos, stuccoes, moulded terracotta elements etc. increases in the respective calculations. However, the shortage of examples on which it has been possible to make this type of comparison does not allow us to assign two ranges of different cost values with any level of certainty according to the monumentality of the cemetery. As a result, the average value is chosen.

In the case of the low damage range, from 1 to 3, the change in cost is absent, with all four cemeteries showing a substantially stable ratio whether they are monumental cemeteries, like Cemetery 5, or cemeteries of lesser importance. Again, the absence of this change is consistent with the type of work required. In the case of cemeteries with low damage indexes, the works have been concentrated on the roof. These have mainly envisaged the insertion of ring beams or ties. Consequently, limited completion works have been necessary

in all types of cemeteries. The weight of the two categories is therefore defined as identified.

In conclusion, the average weight for the different classes of structural and architectural costs to be assigned to the average cost is:

Id: between 0.8 and 1	<b>D4-5</b>	65% - 35%
Id: between 0.6 and 0.8	<b>D3-4</b>	65% - 35%
Id: between 0.4 and 0.6	<b>D2-3</b>	80% - 20%
Id: between 0.4 and 0.2	<b>D1-2</b>	80% - 20%
Id: between 0 and 0.2	<b>D0-1</b>	80% - 20%

Using the GIS database on the damage forms previously created, the area of intervention was identified for the cemeteries for which the unit cost per square metre for all cemeteries belonging to different classes was identified. However, only the projects that at least reach the assignment of the grant<sup>15</sup> were taken into consideration.

DAMAGE CLASS D1-D2	Verified Cost/ Assigned Fund	mq	€/mq
CIMITERO DI FOSSOLI	173 000.00 €	360	480.56 €
CIMITERO DI DISVETRO	200 000.00 €	235.00	851.06 €
CIMITERO DI VALLALTA	314 080.41 €	650	483.20 €
SANTA CATERINA	418 346.69 €	870	480.86 €
CIMITERO DI VILLANOVA DI REGGIOLO	131 242.43 €	182	721.11 €
CIMITERO DI CREVALCORE	4 040 709.55 €	4500	897.94 €
CMITERO DI PIEVE DI CENTO	741 698.29 €	1500	494.47 €
CIMITERO DI SAN GIOVANNI IN PERSICETO	413 750.00 €	1000	413.75 €
CIMITERO DI RENZAZZO	469 574.42 €	900	521.75 €
CIMITERO DI CASUMARO	511 482.75 €	1000	511.48 €
CIMITERO DI RENO CENTESE	298 965.97 €	750	398.62 €
CIMITERO DI MIRABELLO	447 000.00 €	770	580.52 €
CIMITERO DI DOSSO	1 176 949.25 €	1230	956.87 €
CIMITERO DI CENTO	1 304 403.23 €	1950	668.92 €
CIMITERO DI MORTIZZUOLO	428 898.93 €	1085	395.30 €

Tab.2. Cemetery considered in the cost definition for the damage class D1-D2.

From this, we can calculate the average cost per square metre to be applied to each class of damage (Tab. 3). It was also divided into its two components, structural and architectural.

	General average cost per sqm	Structural average cost per sqm	Architectural average cost per sqm
D4-5	1 650.00 €	1 072.50 €	577.50 €
D3-4	1 250.00 €	812.50 €	437.50 €
D2-3	1 100.00 €	880.00 €	220.00 €
D 1-2	600.00 €	480.00 €	120.00 €
D 0-1	250.00 €	200.00 €	50.00 €

Tab.3. Architectural e structural cost applied to the different damage class for the cemetery type.

.....

15 The awarding of grants corresponds to the drawing up and validation of the final project

Although the estimate obtained in this way is more reliable than that provided by the previous valuation method, it is still an estimate affected by various limitations. The most relevant is undoubtedly the identification of the intervention areas using GIS software. For the cemeteries for which it has been possible to find the estimate or part of the projects, the area used is the real area of intervention. However, the identification of other areas by the GIS database is a rough assessment by excess, due to the fact that it is based on the definition of the building boxes of the CTR, within which the historical portions have been identified. These boxes are usually identified through the perimeter inferred by the coverage, which is wider than the real area. Moreover, considering the low number of cemeteries with high damage indexes, between 2.5 and 5 on the specific scale, the average parametric cost of these ranges is rougher than the low ranges, where there are many cases.

Increasingly accurate estimates can therefore be made only later, both by retrieving more detailed metric-estimative data on the 2012 earthquake in Emilia, and by using data from other earthquakes, with particular reference to that in Central Italy in 2016, where there were more cemeteries with high levels of damage.

# CHAPTER 5

## Cemeteries vulnerability: first reflections

Nota la pericolosità sismica, è immediato valutare il livello di danno di ogni struttura (scenario di danno) e definire una lista di monumenti ordinati in funzione del loro rischio.

Il danno medio  $\mu_D$ , dato dalla (1.5), rappresenta un parametro sintetico per la definizione dello scenario di danno; la figura 7.4 mostra le curve di vulnerabilità medie per diverse tipologie di edifici monumentali. Se una valutazione probabilistica è necessaria, la probabilità  $P_k$  ( $k=0,1,2,3,4,5$ ) connessa ad ogni livello di danno, è data dalla distribuzione binomiale (1.2); questi valori possono essere utili per scenari più dettagliati, finalizzati, per esempio, ad individuare la probabilità di collasso di ogni singolo edificio ( $P_5$ ) o la probabilità che un edificio sia dichiarato inagibile dopo l'evento sismico ( $P_3+P_4+P_5$ ). Le curve di fragilità sono pertanto:

$$P[D_k | \mu_D] = \sum_{i=k}^5 P_i = \sum_{i=k}^5 \frac{5!}{i!(5-i)!} (0.2\mu_D)^i (1-0.2\mu_D)^{5-i} \quad (1.6)$$



Figura 1.4. Curve di vulnerabilità medie per diverse tipologie di edifici monumentali.

On the previous page an excerpt from the book by Lagomarsino & Podestà, 2005.

## 5.1 Introduction

Seismic vulnerability and exposure now seem to represent the main cause of the increase, though slight, in the destructive effects of earthquakes perceived by populations (Zuppiroli, 2019b). In Italy and abroad, in order to understand their real impact and to address the policies of seismic improvement or reconstruction of historic buildings after the earthquake, many studies and researches have focused on procedures for assessing vulnerability according to a specific building classification (Calvi et al., 2006). As previously indicated in Section 1.5, the damage survey forms requires the identification of parameters that allow the analysis of vulnerability on an urban or territorial scale, even if they are elaborated with the final aim of assessing practicability and estimating economic damage in the case of cultural heritage. These forms have already been used for to analyse damage scenarios in the emergency phase, but their extensive use by filling in just the basic fields would not only facilitate the survey of damage during the emergency phase, as it is pre-filled during ordinary management, but would also allow the performance of vulnerability analyses in order to more effectively target seismic improvement policies on different territories.

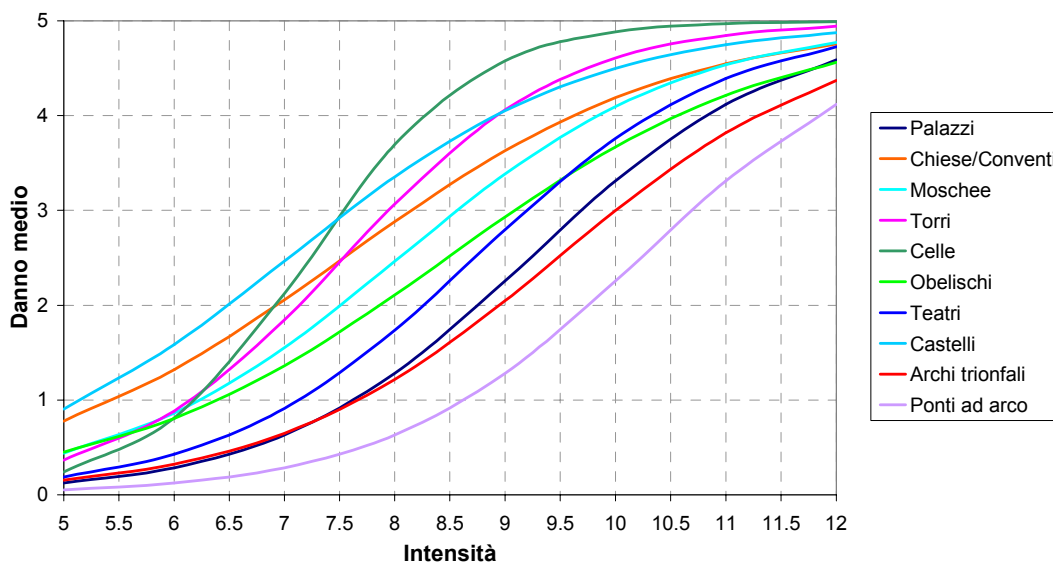
Undoubtedly, in the case of basic buildings, the extensive use of instruments is extremely complicated and feasible in rather restricted circumstances, such as the case of Ferrara, while the smaller, though still considerable, amount of cultural heritage would qualify them as the most suitable. To date, however, analysis of monumental assets on a territorial scale is still rare, with the regional Superintendencies preferring more targeted and expensive<sup>1</sup> analyses on those assets considered “priority”<sup>2</sup>. However, the ability of damage assessment devices to act as proactive tools is one of their most unexpressed but considerable potentialities, which is why this feature will be preserved in the new instrument.

Over the following pages, starting with the description of some typical vulnerability assessment models, we will identify and analyse the parameters useful for the definition of an index of vulnerability for cemetery type, which can be acquired through a simple building inspection. Basing this analysis on data observed on a sample of buildings - cemeteries - after the seismic event - the 2012 Emilia earthquake -, we will refer to a first-level empirical approach, suitable for large scale analysis, on an urban and national level. This choice is consistent both with the data available and with the aim of the research itself, which is aimed, on one hand, at improving damage survey procedures, a first-level approach, and, on the other, at identifying procedures to address policies for risk mitigation.

First-level approaches use qualitative and quantitative data based on real-world observations and are well-suited to developing seismic vulnerability assessments for large-scale analyses. The second level approaches, on the hand, are based on mechanical models. This means that they have more detailed and reliable data (geometric and mechanical) on the building stock under investigation. Lastly, there is a further level that involves the use of numerical modelling techniques which require a detailed and thorough investigation of individual buildings. The definition of the aims (the assessment of a single building, an aggregate or

.....  
 1 In terms of time, type of analysis and computational effort, not just financial.

2 In terms of historic and artistic value, economic profit, image, there are many different factors that draw attention to one type of cultural heritage rather than another.

an urban sector, and so on) and the nature of the data available (qualitative, quantitative...) influence the choice of the method (Fig.1), identifying the first-level approach, based on empirical observations, as the most suitable for the case under analysis.

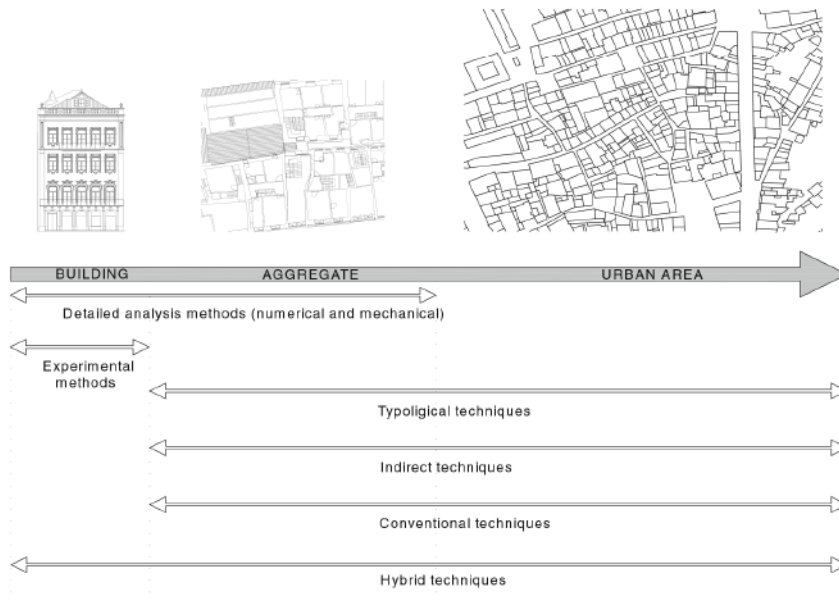

Fig.1. Vulnerability methods and its application scales (Vicente et al., 2011).

In particular, similarly to other works (Vicente, 2008; Ferreira et al., 2013; Basaglia, 2016; Ortega et al., 2019a), the study proposed in this research combines the vulnerability index method (Benedetti & Petrini 1984) with the macro-seismic method (Giovinazzi & Lagomarsino, 2004d; Lagomarsino & Podestà, 2005). The results achieved have been included in the first sections of the damage survey form for cemeteries.

This procedure has two main benefits. On the one hand, it enables to estimate a vulnerability index ( $I_v$ ) for each building on the basis of certain parameters rather than using a typological index. This type of index is automatically attributed to all buildings belonging to the same class without considering any features that can distinguish them. On the other hand, the method proposed allows the calculation of the average damage using the macro-seismic formulation (1), which correlates it to the seismic input expressed as macro-seismic intensity ( $I$ ), to the vulnerability ( $V$ ) and to a ductility factor ( $Q$ ) of empirical nature.

$$\mu d = 2.5 \left[ 1 + \tanh \left( \frac{I + aV - b}{Q} \right) \right]$$

The correlation is possible through the identification of the relationship, defined by the formula (2), between the vulnerability of the formula (1) ( $V$ ) and the vulnerability index ( $I_v$ ) calculated through the analysis of the parameters.

$$V = c + d * I_v$$

As a result, vulnerability curves for cemetery organisms can be defined. To date, in fact, several public and monumental building are just investigated, but no data are available concerning the cemetery *type*.



It should be pointed out, however, that the main limits of empirical methods include their close dependence on the constructive features of the objects investigated and on the seismic scenarios, on the basis of which these methods are formulated and calibrated. This can lead to rough estimates of both vulnerability and expected damage. However, their application in similar contexts in terms of constructive features leads to a fair limitation of the uncertainty of the result accuracy and to a fairly good assessment of the territorial scale. This type of accuracy can be considered valuable to guide the decision-making process.

In the case of historic cemeteries, since these are specialised buildings, with characteristics that are less related to the places where the buildings were built and which were built in a limited historical period, we should also take into account the fact that the applicative context can potentially range from regional to national, with the proper in-depth analysis, as in the case of churches (Lagomarsino & Podestà, 2005).

The current limitations of the following study will be discussed at the end of the chapter to draw the lines of investigation that will allow an implementation of the method applied. For the type of data investigated, often obtained from the damage forms, but also closely related to the constructive characteristics of the cemetery type, the study proposed is configured as an analysis carried out using Exposure and Vulnerability data.

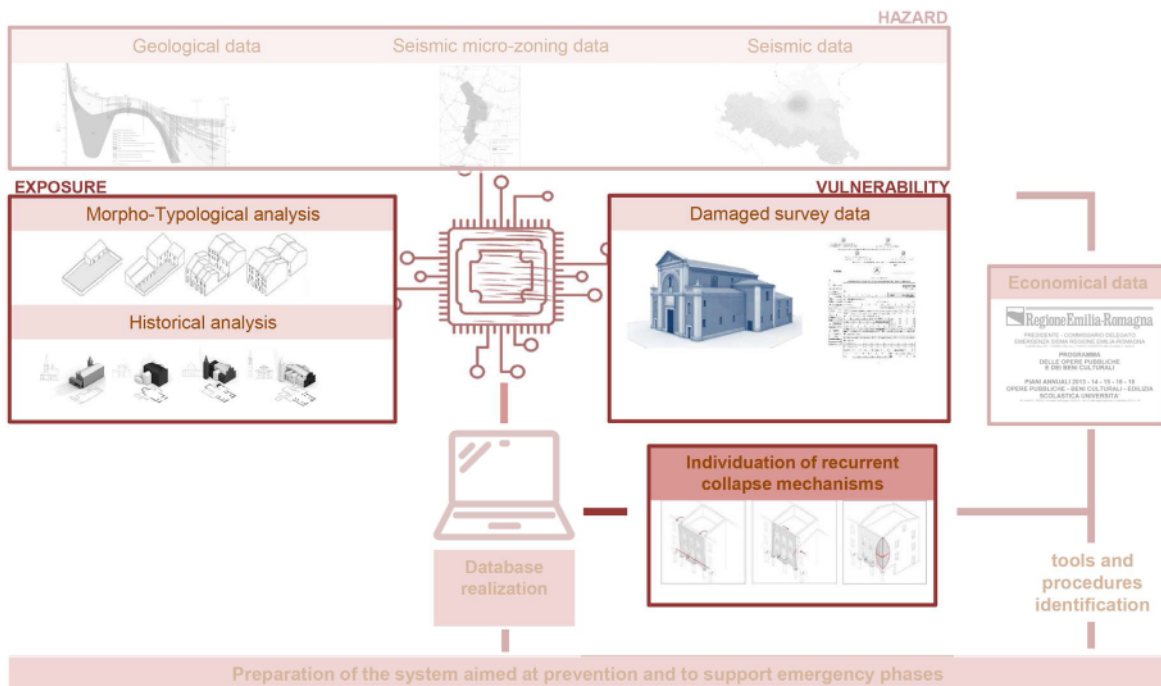

## 5.2 Protocol samples for the vulnerability assessment of historic buildings based on the Vulnerability Index (Iv)

- **Introduction**

As currently structured, the first-level forms operating within the Italian context refer to macro-seismic first-level approaches (forms for Cultural Heritage) or vulnerability index approaches (AeDES forms). In the first case, we refer to fields such as location, state of preservation, regularity in plan or elevation, which correspond to the improving or worsening effects of typological vulnerability according to the following formulation:

$$(1) \quad V = V_0 + \sum V_k$$

Here  $V_0$  is the typological vulnerability and  $V_k$  are the behaviour modifiers. Then, the vulnerability curve for the type was identified from this index according to formula (1).

In the second case, the data collected in specific sections of the form are attributable to the GNDT second-level protocol. Although the GNDT survey protocol is a second-level procedure, it is also worth noting that the approach to the analysis of vulnerability generally applied is first-level. This confirms the definitive division between the type of data collected (second-level, i.e., more accurate) and the approach to vulnerability applied.

Considering, therefore, the benefits of the combination of both methods, macro-seismic and vulnerability index, and considering that only the macro-seismic approach, which can be used with the current forms for cultural heritage, does not seem to be applicable to the present case since regional and specific modifiers of behaviour for the investigated sample are homogeneous (context, regularity in plan, regularity in elevation, etc.), we opted for a combined analysis of the two methods as defined in Section 5.1. The first step was the study of those parameters which are mainly responsible for the seismic response of the structure. Both a scale of values from A to D indicating the increasing vulnerability for that parameter (A=0 vulnerability, D= maximum vulnerability), and the weight of the parameter, i.e., its relevance among the characteristics of vulnerability, were then assigned. Once the vulnerability index protocol had been identified, it was finally correlated to the macro-seismic approach. Based on this, we preliminarily identified different protocols that already exist for different areas or building features in order to assess their use or to extrapolate relevant parameters also in the case of cemetery structures. The particular architectural and structural layout of the cemetery, in fact, required a preliminary screening in order to identify the best approach, even in presence of parameters that are conceptually relevant but not detectable and categorisable with the same range identified by existing protocols.

- **Italian and foreign samples of operational protocols: formulation and application context**

The **second-level GNDT method** (GNDT, 1994) has already been briefly presented in the section 1.3. In spite of representing one of the first methods that implemented the study carried out by Benedetti and Petrini (Benedetti & Petrini, 1984)<sup>3</sup>, it is applicable only to isolated masonry buildings, i.e., factors affecting vulnerability resulting from the building's inclusion in a stock are not taken into account.

Parameters	Short description	Vulnerability Class				Weight	
		A	B	C	D		
<b>P1</b>	Organization of vertical structures	Age of the construction and connection typology between the walls	0	5	20	45	1
<b>P2</b>	Nature of vertical structures	Vertical element typology	0	5	25	45	0.25
<b>P3</b>	Qualitative resistance	Walls' shear strength assuming box behaviour	0	5	25	45	1.5
<b>P4</b>	Location of building and type of foundation	Topographical conditions of the ground and foundations characteristics and depth	0	5	25	45	0.75
<b>P5</b>	Floor typology	Quality of floor type considering stiffness and connection with the walls	0	5	15	45	1
<b>P6</b>	Plan regularity	Length/width ratio of the building plan	0	5	25	45	0.5
<b>P7</b>	Height regularity	Mass variation in elevation and the presence of arcades or towers	0	5	25	45	1
<b>P8</b>	Distribution of plan resisting elements	Ratio between wall cross walls span and thickness of main walls	0	5	25	45	0.25
<b>P9</b>	Roof typology	Weight and characteristics (thrust) of the roof	0	15	25	45	1
<b>P10</b>	Non-structural elements	Presence, typology and connection to the building	0	0	25	45	0.25
<b>P11</b>	Physical conditions	Masonry quality and cracking scenario	0	5	25	45	1

Parameter P1 evaluates the characteristics that should guarantee the box-like behaviour of the building, regardless of the type of material with which it is made. For example, it evaluates the presence of chains or edge beams and takes into account compliance with anti-seismic standards, according to the age of the construction.

Parameter P2, on the other hand, takes into account the type of material with which the building is built. The type of material, uniformity of the courses, the presence of squared elements, of poor-quality or extra tick mortar respond differently to seismic stress<sup>4</sup>.

.....

<sup>3</sup> The method proposed, which is very similar to the method later validated by GNDT, used only ten parameters. Compared to the GNDT method, which has eleven parameters, parameter P3 was not included and was evaluated within parameter P4 (corresponding to P8 in the current method).

<sup>4</sup> With regard to this, the studies for the definition of the Masonry Quality Index (IQM) are of particular interest for historical buildings. The IQM gives values for the resistances to be used in the seismic analysis through the evaluation of certain parameters (Borri & De Maria, 2019).

Parameter P3 provides an estimate of the resistance of a masonry building to horizontal actions through a simplified formulation that compares the response of the building in its weak direction to an equivalent shear wall.

Parameter P4 evaluates the building's location in relation to the morphology of the surrounding area and the soil type, and estimates the characteristics of the foundations, taking several factors into account.

Parameter P5 takes into account the quality of the horizontal diaphragms and their connection to the vertical structures, considering their importance in transmitting the seismic action.

Parameter P6 takes into account the regularity of the plan. In the case of seismic action, the presence of an eccentric mass barycentre constitutes a stress factor. In this particular case, the regularity of the plan is evaluated using two factors,  $\beta_1$  and  $\beta_2$ , according to the

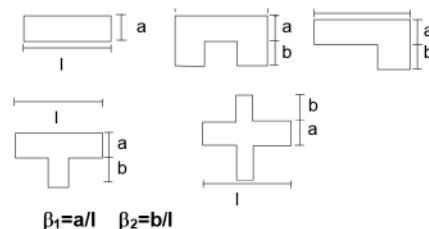

Fig.2. Scheme of the possible plan configurations considered in GNDT second-level form.

planimetric features of the buildings, as shown in Fig. 2.

Parameter P7 refers to the regularity of the stiffnesses on the different storeys of a building, considering the presence of porticos and loggias.

Parameter P8 takes into account the presence of cross walls, which form a constraint to the load-bearing walls, excluding partitions. Classes are defined according to the ratio between the spacing of the cross walls and the thickness of the main walls.

Parameter P9 rates the type and weight of the roof structures and therefore the thrust they transmit to the vertical structures, as well as the efficiency of the connection to the latter.

Parameter P10 takes into account the presence of non-structural elements such as chimneys, ceilings and other elements which may induce further damage or affect people by collapsing.

Parameter P11 takes into account the condition of the building and the pre-existence of damage.

**The Formisano method** (Formisano et al., 2015) attempts to go beyond the GNDT method, starting from the ten parameters of the Benedetti-Petrini method, with the introduction of five additional parameters that take into account the placement of the building units in urban aggregates and the relative added vulnerability. Compared to the GNDT method, the

assessment of masonry quality is eliminated and negative values are introduced for the new parameters. In this way, the method can take into account the positive effects of the integration of building units in aggregates, which reduces their vulnerability.

Parameters	Short description	Vulnerability Class				Weight	
		A	B	C	D		
P1	Organization of vertical structures	Age of the construction and connection typology between the walls	0	5	20	45	1
P2	Nature of vertical structures	Vertical element typology	0	5	25	45	0.25
P3	Location of building and type of foundation	Topographical conditions of the ground and foundations characteristics and depth	0	5	25	45	0.75
P4	Distribution of plan resisting elements	Ratio between wall cross walls span and thickness of main walls	0	5	25	45	1.5
P5	In-plane regularity	Length/width ratio of the building plan	0	5	25	45	0.5
P6	vertical regularity	Mass variation in elevation and the presence of arcades or towers	0	5	25	45	0.5-1
P7	type of floor	Quality of floor type considering stiffness and connection with the walls	0	5	15	45	0.75-1
P8	Roofing	Weight and characteristics (thrust) of the roof	0	15	25	45	1
P9	Details	Presence, typology and connection to the building of non-structural elements	0	0	25	45	0.25
P10	Physical conditions	Masonry quality and cracking scenario	0	5	25	45	1
P11	Presence of adjacent buildings with different height	height's variation	-20	0	15	45	1
P12	Position of the SU in the SA	Location of the SU in the SA	-45	-25	-15	0	1.5
P13	Presence and n° of staggered floors	Number of staggered floors in the SA	0	15	25	45	0.5
P14	Structural or typological heterogeneity among units	Effect of structural or typological heterogeneity in adjacent SUs	-15	-10	0	45	1.2
P15	Misalignment of openings among the SUs	% difference of openings in adjacent facades	-20	0	25	45	1

The five additional vulnerability parameters and their meanings are listed below.

Parameter 11 takes into account the variation in height between adjacent units that can generate additional vulnerabilities when thrusts are not transmitted evenly.

Parameter 12 considers the location of the building in the urban aggregate taking into account the number of sides that are directly adjacent to other units. In this case, the parameter evaluates the benefits of buildings for being in positions within the aggregate as opposed to corner positions where seismic forces are typically concentrated.

Parameter P13 evaluates the staggered floors among the different units that can generate punching effects due to the fact that the forces are not transmitted uniformly.

Parameter P14 assesses structural heterogeneity among adjacent units by considering complete heterogeneity or the best/worst construction quality for structurally similar buildings.

Parameter P15 evaluates the real size of resistant elements in façades through the identification of openings among different building units.

Starting again from the GNDT formulations or from those of the Benedetti-Petrini method,

many different protocols have been designed also abroad to adapt to the various geographical contexts and therefore appreciate different typological-constructive characteristics.

For this study, we have to mention the contribution of Vicente who, unlike the methods mentioned above, correlated his own method with the macro-seismic approach. It is also based on the GNDT method but it was adapted to the Portuguese context. In fact, the **Vicente method** (Vicente, 2008; Vicente et al., 2011), which was tested in the Coimbra center, groups the parameters into four macro-classes redefining some criteria of the GNDT method<sup>5</sup> and adding three more parameters in order to take into account the aggregate behaviour.

Parameters	Short description	Vulnerability Class				Weight		
		A	B	C	D			
<b>1.Structural building system</b>								
P1	Type of resisting system	Construction age, quality of walls' connection		0	5	20	50	0.75
P2	Quality of the resisting system	Vertical Element Typology		0	5	20	50	1
P3	Conventional strength	Walls' shear strength assuming box behaviour		0	5	20	50	1.5
P4	Maximum distance between walls	Spacing between walls		0	5	20	50	0.5
P5	Number of floors	Number of floors in the building		0	5	20	50	1.5
P6	Location and soil conditions	Topographical conditions of the ground and foundations characteristics		0	5	20	50	0.75
<b>2.Irregularities and interaction</b>								
P7	Aggregate position and interaction	Position of the SU in the SA		0	5	20	50	1.5
P8	Plan configuration	Length/ width ratio of the building plan		0	5	20	50	0.75
P9	Regularity in height	Mass variation in elevation and the presence of arcades or towers		0	5	20	50	0.75
P10	Wall façade openings and alignments	Influence of the misalignment		0	5	20	50	0.5
<b>3. Floor slabs and roofs</b>								
P11	Horizontal diaphragms	Quality of floor type considering stiffness and connection with the walls		0	5	20	50	1
P12	Roofing system	Weight and the roof typology (thrust)		0	5	20	50	1
<b>4.Conservation status and other elements</b>								
P13	Fragilities and conservation state	Masonry quality and cracking scenario		0	5	20	50	1
P14	Non-structural elements	Type and characteristics of the non-structural elements		0	5	20	50	0.5

Parameter P5 takes into account the number of floors present, starting from the consideration that taller masonry structures tend to be more sensitive to seismic action.

Similarly to parameter P12 of the Formisano method, parameter P7 refers to the building's position in the structural aggregate.

Lastly, like parameter P15 of the Formisano method, parameter P10 evaluates how misalignment of openings negatively affects the seismic resistance of structures.

Once the *I<sub>v</sub>* was identified, Vicente correlated it to formula (4) through formula (2) by assigning parameters c and d values of 0.56 and 0.0064, respectively.

.....  
 5 For example, parameter P4, which corresponds to P8 of the GNDT method, is redefined through the identification of the largest span between the cross walls, no longer the ratio between the span and the thickness of the bearing walls.

$$(4) \quad \mu d = 2.5 \left[ 1 + \tanh \left( \frac{1+6.25V-12.7}{q} \right) \right];$$

$$(2) \quad V = c + d * Iv.$$

This first work was later reviewed and applied to the center of Seixal, also in Portugal, again by Vicente, Ferreira, Mendes da Silva, Varum and Costa (Ferreira et al., 2013), re-evaluating the correlation with the macro-seismic method according to formulas (5) and (6):

$$(5) \quad \mu d = 2.5 \left[ 1 + \tanh \left( \frac{1+6.25V-13.1}{q} \right) \right];$$

$$(6) \quad V = 0.592 + 0.0057 * Iv.$$

On this same occasion, Ferreira also experimented with a further quick method to assess the vulnerability not of each individual building, but of the aggregate. This method was applied both in the experimentation carried out in Coimbra, when detailed information on single buildings was lacking<sup>6</sup>, and in Italy. The **Ferreira method** is based on a few easily detectable parameters and due to its simplified nature is set up as a tool for the preliminary assessment of building stocks.

Parameters	Short description	Vulnerability Class				Weight	
		A	B	C	D		
P1	Quality of the masonry fabric	Type of masonry among the SUs in the aggregate	0	5	20	50	1.5
P2	Misalignment of openings	Ratio between the number of staggered floors and the total number of the adjacent floors.	0	5	20	50	0.5
P3	Irregularities in height	Difference in height among adjacent structural units	0	5	20	50	0.75
P4	Plan geometry	Plan irregularity, using a relationship between the area and the perimeter	0	5	20	50	0.75
P5	Location and soil quality	Quality of the ground foundation and the slope of the aggregate	0	5	20	50	0.75

As this is a method for evaluating building stocks, the different parameters refer to global evaluations on all the buildings within them. With this in mind, parameter P1 evaluates the constructive homogeneity of the aggregates. The materials are then grouped into sub-classes on whose percentage recurrence the vulnerability assessment is based.

Parameter P2 analyses the opening misalignment and the related presence of staggered floors within the stock.

Parameter P3 assesses the presence of irregularities in height according to an average which can be assigned to the whole cluster.

Parameter P4 evaluates the irregularity in plan. Referring to building stock which can have a complex shape, unlike previous methods, the parameter is calculated through a mathematical relationship between Perimeter (P) and Area (A) as shown in the formulation (7).

$$(7) \quad P4 = \frac{16A}{P^2}.$$

On the contrary, parameter P5 evaluates the type of foundation and the slope of the ground, as just identified in other formulations.

.....  
 6 In this case, the method previously described was not suitable.

Lastly, another assessment method, called **SVIVA** (Ortega et al., 2019a; 2019b), is the protocol proposed by Ortega, Vasconcelos, Rodrigues, and Correia for vernacular architecture. This method, developed on the basis of Portuguese architecture, takes into account specific constructive features that are widely used in other contexts. For this reason, its formulation is considered suitable even outside the context in which it was originally designed, particularly that of Mediterranean Europe and therefore Italy.

Parameters	Short description	Vulnerability Class				Weight		
		A	B	C	D			
P1	Wall slenderness	Ratio between the effective wall inter-story height (h) and its thickness		0	5	20	50	1
P2	Maximum wall span	Maximum length spanned by a wall prone to out-of-plane movements		0	5	20	50	0.5
P3	Type of material	Nature of the material used to build the load bearing walls		0	5	20	50	1.5
P4	Wall-to-wall connections	Organization of the vertical structural system in terms of the level of connection between the orthogonal walls		0	5	20	50	0.75
P5	Horizontal diaphragms	Construction solutions and materials used to consider stiffness and connection		0	5	20	50	1.5
P6	Roof thrust	Possible thrust exerted by the roof to the load bearing walls		0	5	20	50	0.5
P7	Wall openings	Ratio between the total area of wall openings in all earthquake resistant walls in one direction and the total surface area		0	5	20	50	1.5
P8	Number of floors	Number of floors of the building under study		0	5	20	50	1.5
P9	Previous structural damage	degree of deterioration existing in the load bearing walls of the buildings and the weakening signs		0	5	20	50	0.75
P10	In-plane index	Ratio between the in-plane area of earthquake resistant walls in each main direction ( $A_{wi}$ ) and the total in-plane area ( $A_w$ )		0	5	20	50	0.5

Parameter P1 evaluates the slenderness of the masonry. Although historical buildings are generally of modest height, this parameter, if appropriately calibrated, evaluates the resistant capacity for actions out-of-plane of the façades.

Parameter P2, similarly to parameter P4 of the Vicente method, assess the span.

Parameter P3 evaluates the material of the buildings.

Parameter P4 is used to take into account the connections between the masonry.

Like similar parameters in other methods, parameter P5 assesses the type and the stiffness of the horizontal diaphragms, and parameter P6 evaluates the type and weight of roof structures.

Parameter P7 estimates the presence and size of openings compared to the earthquake resistant area. These compromise earthquake resistance for in-plane actions of the walls.

Parameters P8 and P9 consider the number of floors and the pre-existing damage, respectively.

Parameter P10 provides an estimate of the shear resistance in the two main masonry directions and, in the case of historic architecture, is also an indicator of regularity in plan.



The estimate is obtained through the evaluation of the resistant sections in the plan.

Also related to the macro-seismic method, in the case of the SVIVA method the formulation and parameters are:

$$(4) \quad \mu d = 2.5 \left[ 1 + \tanh \left( \frac{I+6.25V-12.7}{q} \right) \right];$$

$$(6) \quad V = 0.46 + 0.012 * Iv.$$

These are only some of the several methods developed in Italy and abroad. However, their analysis is already enough to encourage reflection on their application to the case of cemetery type.

- **Criticality of the application of existing methods to cemetery type**

As they are created and validated on the basis of ordinary buildings, the direct application of the aforementioned methods to cemetery structures has obvious limitations. In fact, cemeteries are not basic buildings but a specialised type with specific features related to their function that cannot be easily assessed with validated methods. This can result in parameters that lose their meaning when applied to a cemetery or in parameters whose definition needs to be revised according to the actual characteristics of the cemetery.

For historical cemeteries, the following items can be considered meaningless:

- number of floors: historical cemeteries are buildings with a single floor which, nevertheless, can have a significant height. In some cases, there may be a basement or a podium.
- height irregularities: the architectural configuration of cemeteries limits, and in some cases eliminates, the presence of significant height variations that can make the parameter effective. These, on the rare occasions when they are present, are limited to passing elements, often of new construction.
- assessment of openings: if we consider the presence of windows, the openings in cemeteries are extremely rare and are not a significant parameter. If porticoed areas are considered (total opening), the parameter does not assume significance since the resistant section is almost null.

Some features can only be used after redefining their application criteria. This is the case with:

- regularity in plan: in the GNDT protocol (parameter P6) and, therefore, in all those derived from it (P5 for Formisano P8 for Vicente), regularity in plan as it is defined loses its meaning for almost all cemeteries. In fact, even if the ratios of the  $\beta$  coefficients give different results on the regularity in plan of cemeteries, the presence of porticoed or loggia areas, which are a typical feature of the cemeteries, greater than 10% of the surface, would qualify almost all of them in the class of greater vulnerability. This makes the evaluation of plan irregularity for cemeteries essentially uniform, so it is not useful for the purpose of the final evaluation. From this point of view, considering the analogy between a city and a cemetery, the definition implemented in the Ferreira method (the ratio between the perimeter and

the area (P4)) seems to acquire more significance. However, this is a parameter that is borrowed from a method for building stock and not single buildings.

- Wall slenderness: slenderness is undoubtedly a strong component of vulnerability in out-of-plane behaviour. This is directly considered for only one of the methods investigated (P1, SVIVA) in order to understand the risk of walls overturning. In the case of cemeteries, however, the slenderness to be evaluated should be not only that of the part of the building that contains the niches, but especially that of the pillars of the arcade, which are perhaps more vulnerable to the out-of-plane actions than the walls.
- connection between walls: this parameter can be considered significant for cemeteries as they are buildings in a state of permanent development, as shown in section 3.3. However, the specific nature of cemeteries, which does not allow for the investigation of cross walls as they house burial niches, makes it necessary to reconsider the criterion for its definition. In fact, the criterion provided by the GNDT protocol (P1), which evaluates compliance with seismic standards, does not seem applicable as it can be satisfied for all building sections without, however, mutual support among elements. Lastly, it cannot be evaluated even only through the degree of visually detectable disconnection among cross walls, as in the case of parameter P4 of the SVIVA method.

In conclusion, cemetery type, due to its unique features, requires a redefinition of the parameters necessary for the assessment of its vulnerability, so as to be more closely related to the architectural and constructive reality of this specialised type.

### ***5.3 Study and identification of potential parameters for defining a vulnerability protocol for cemetery type***

- ***Identification of potentially relevant parameters***

Based both on the parameters commonly used in the vulnerability assessment protocols and on the architectural characteristics peculiar to cemetery type, certain parameters that could influence the vulnerability of the cemeteries were first identified. These parameters were then analysed in relation to the sample under investigation, namely the cemeteries damaged by the 2012 Emilia earthquake, to identify which were relevant to understand the earthquake vulnerability.

The first parameter evaluated was the construction quality of the vertical structures. Here, the set under examination immediately showed certain limitations, mainly to parameters such as the slope of the area. Since all the cemeteries are located within the Po Valley, they are consistent in terms of their construction materials (i.e., brick masonry with rare stone or concrete columns) and the soil features (slopes) on which the buildings are built. However, in fact, both characteristics can vary appreciably (Figs. 3-4) in ways that cannot presently be assessed.



Fig.3. Cemetery of Poggio Cupro (Marche region) built with stone masonry. Ph Arch. Marta Zannotti



Fig.4. Cemetery of Airo (Marche region) Columbaria in a slope configuration. Ph Arch. Marta Zannotti

Apart from these two parameters, 11 parameters, which could influence the cemetery's vulnerability and were easily detectable through an inspection, were then analysed. The identified parameters were analysed based on data extrapolated from the vulnerability features related to the parameters for the cemeteries under investigation. Data collection encompassed damage forms, photographs, and data obtained from the projects. Then, on the basis of the results gathered from this collection, the relevance of the different parameters on cemetery vulnerability were evaluated. The purpose of this evaluation was to identify which of them could be included within the new form.

The first two parameters identified were the slenderness of the portico structures (columns, and pillars) and the slenderness of the back wall. These two refer to the out-of-plane mechanisms of the colonnade and of the back wall, which were activated with different recurrence for the cemeteries under investigation. Cemeteries, in fact, generally being one-story structures, are characterized by fairly slender masonry for both elements. Slenderness was identified through the ratio of thickness to height of columns/pillars or walls. Therefore, an attempt was made to understand whether the increase in the slenderness of these elements could relate to the damage suffered by the cemeteries.

Another parameter analysed was the distance between cross walls. As shown in section 3.4, there are two main construction patterns: with cross walls or without them. In the first case, it is possible to identify some wheelbases which remain substantially constant. Since the cemeteries have kept a fairly standard coffin width (about 80 cm), these wheelbases are determined by the number of niches housed between pillars, varying in the set investigated from two niches for about 2-2.5 m (Fig. 5) to 4 niches for 5 m (Fig. 6). The change of these pitches therefore produces different patterns in the distribution of the cross elements.

In the second case, on the other hand, it was impossible to identify any constructive scheme because the rhythm of the walls is completely independent and can take wheelbases even greater than 10 m.



Fig.5. Cemetery of Mortizzuolo (Modena crater area).



Fig.6. Cemetery of Bevilacqua (Bologna crater area).

The fourth parameter analysed was the horizontal frames. These frames were largely collapsed or damaged by the 2012 earthquake, becoming a rather vulnerable element of the cemeteries. In accordance, the varied stiffnesses of the horizontal structures were evaluated with existing tools. The classes of increasing vulnerability were then identified, starting from the rigid diaphragms in hollow-core concrete structures and going to the most flexible diaphragms, the vaults, analysed separately with or without tie. Starting from these edges, all the intermediate levels were identified (i.e. semi-rigid diaphragms such as SAP<sup>7</sup> floors or semi-flexible diaphragms such as wooden floors with single frames).

The fifth parameter was the overall state of conservation, taken directly from section B16 of the B-DP form. This parameter was, in fact, already divided into the usual classes of analysis: good, fair, sufficient and poor.

The sixth parameter considered was roof thrust. This parameter is also a highly relevant to evaluate for cemetery structure, as it can affect colonnade damage in columbaria. In fact, the thrust of these structures or - on the contrary, the presence of elements that absorb this thrust - has generally a strong influence on the out-of-plane behaviour and on the worsening of seismic stress. Even in this case, however, many methods suggest an easy classification by type of thrust and weight of structures, which assigns the greatest vulnerability to the thrusting and heavy roofs.

With respect to the seventh parameter, cross-connections were considered (parameters P7 of SVIVA and P1 of GNDT). As previously discussed in section 5.2, this parameter for cemetery entities must be revised in the light of their architectural configuration and the impossibility of inspecting cross walls where present. Therefore, for this parameter it has been decided to assume as always satisfied the rule of art within each extension realized. This latter, the extensions, are used to define the degree of connection between the structures instead. In fact, the cemeteries are generally completed so that they can be

.....  
7 Solaio Auto Portante: self-supporting floor.

extended in the future (Fig. 7), but this arrangement is not adequate to give an effective interlocking between the sides. In case of an earthquake, this peculiarity becomes a weak point of the structure.



Fig.7. Mortizzuolo cemetery (Modena crater area): the columbarium ends with a predisposition of growing.

For example, in the cemetery of Bondeno, the structures collapsed inside an addition. In fact, this could not transfer the roof thrust (probably pushing) to the whole resistant structure of the façade, but only to part of it which, in turn, was not retained at the edges for lack of interlocking in the wall (Fig. 8).



Fig.8. Bondeno cemetery (Ferrara crater area): building collapse at the growing interface. It should be noted the brick disposition that emphasise an addition.

Concerning this specific parameter, the vulnerability assessment was therefore considered to be increasing in relation to the type of additions built during the development of the historical sections of the cemetery. It starts with the lowest vulnerability, the absence of additions, up to the presence of many small additions, to which corresponds the highest vulnerability.

The eighth parameter evaluates the in-plane index (i.e., investigates the lower of the shear strength estimates in the two main wall directions). The estimation is to be done through evaluation of the resistant areas in the plan. This parameter in cemetery architecture conveys has several positive aspects. First of all, it allows for evaluation of the different resistant capacities of structures with or without portico. In this second case, in fact, the porch absence tends to provide higher values of resistance because in front of an approximately similar surface of the resistant walls, the total area under examination decreases. Secondly, the parameter succeeds in considering the divergent resistant capacities of structures with structural grid in masonry and those without it (i.e. it succeeds in evaluating also the presence of very different spaces between cross walls). Vulnerability classes were assigned on the basis of the values obtained for the investigated group. The confirmed relevance of this parameter therefore implies possible future calibration as the number of samples analysed increases.

The ninth parameter assesses the presence of projecting structural elements. These elements are common within cemeteries and, in the case of Emilia-Romagna's cemeteries, have often collapsed to the ground. They may be individual punctual elements, which occur only in select cemetery locations, such as in passing elements, or they may be widespread elements within the building. Due to the risk of collapse of these elements both for people and for the structures themselves (internal collapse), the vulnerability has been evaluated as increasing according to presence, spread (sporadic or along the whole perimeter), and height of the elements.

The tenth parameter was taken from the Formisano method. The continuous growth of cemeteries did not halt with the advent of regulations for the protection of historic buildings. On the contrary, the growth has continued alongside the cemeteries through the construction of new elements figuratively similar but of different construction constructively different. To account for possible effects arising from the presence/connection of newly built structures, not always under protection, the parameter of structural heterogeneity between different units was introduced. In this case, structural unity is defined as different new cemetery areas connected to the historical parts. The parameter classification has remained unchanged with respect to the Formisano method. Therefore, it moves from the heterogeneity of the least vulnerable class to construction with similar techniques but better materials as the worst class.

As the eleventh parameter evaluated, the plan configuration was finally reviewed. In this case, since the cemetery layouts are more complex than the plans of basic buildings, although they are not more variegated, several methods were evaluated to assess the planimetric irregularity. In analogy with the GNDT method, geometric coefficients  $\beta$  were calculated. However, the class change according to the presence of porches was not considered. The ratio between built area and perimeter was calculated as in the Ferreira method for urban aggregates. Then, the increase of vulnerability was evaluated through the number of connections between sections, assuming that the absence of intersections corresponds to a simple figure and that the increase of these intersections implies the realization of an increasingly complex shape with an eccentric centre of masses. Finally, a scale has also been hypothesized for simple evaluation of the shape. Since cemeteries are in any case slender and long constructions (characteristics that affect the coefficients of the GNDT method), vulnerability was classified with respect to the type of figure: simple rectangular, L-shaped, C-shaped or enclosed.

These 11 parameters were then analysed to identify whether, even in the cemetery case, they might have influence and the weight of that influence. The analysis was also repeated for each possible assessment indication related to the eleventh parameter, the planimetric configuration.

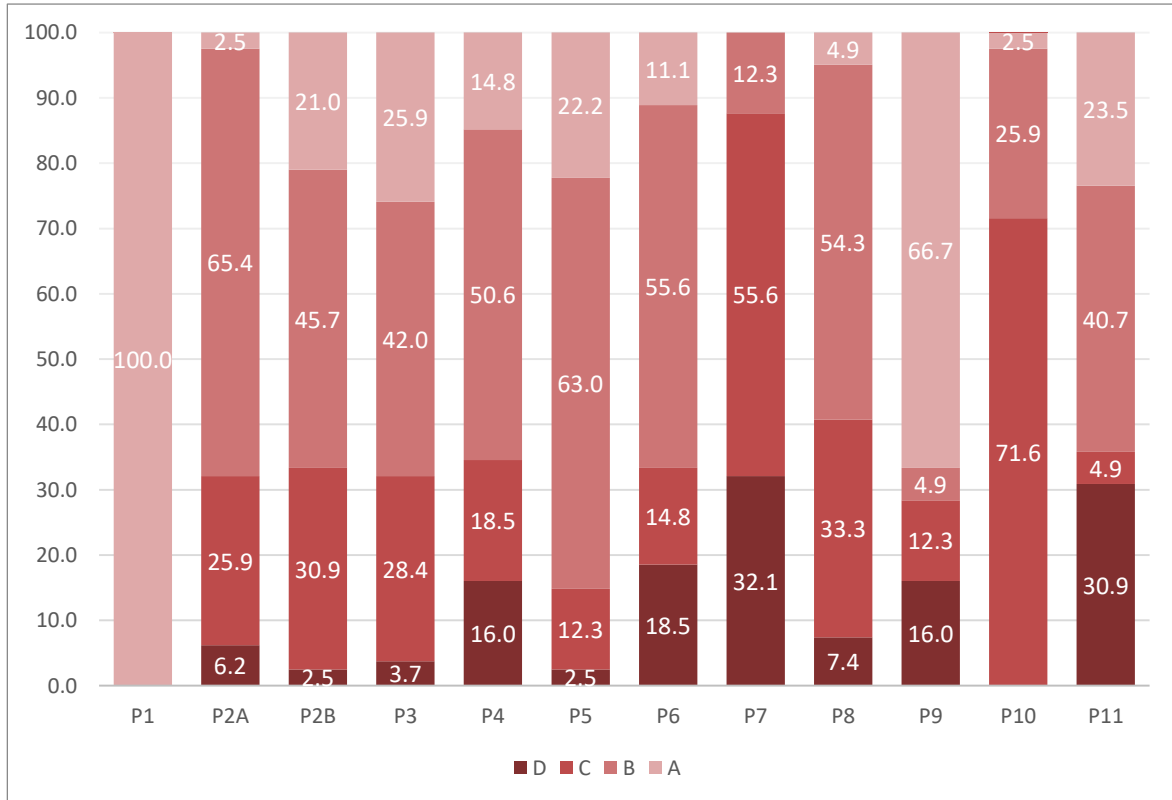

Chart 1. Vulnerability class distribution of each parameter investigated in the sample.

- **Identification of the operational protocol for the vulnerability index assesment**

On the basis of these parameters, scores from 1 to 4 were assigned to the cemeteries within the crater area. They indicate the increasing vulnerability of the cemetery with respect to the parameter considered. Then, three different subsets were created according to the different macro-seismic intensity and attributed to the areas where they are located. Using the software R!, the different clusters were investigated in order to identify, using linear regression, which parameters were found to influence the damage that occurred in 2012. In other words, the ability of the different parameters to predict seismic damage was investigated. Three functions were identified based on the following structure:

$$\text{XRM: } D = P1 + P2a + P2b + P3 + P4 + P5 + P6 + P7 + P8 + P9 + P10$$

These, for each cluster, should therefore lead to a formulation such as:

$$D = a + b \cdot P_x + c \cdot P_y + d \cdot P_z + \dots$$

The final results of the linear regressions led to the identification of seven parameters, variously distributed across the groups, which demonstrated a fair predictive ability (Charts 1,2,3).

- High intensity cluster:

$$D = -1.1827 + 0.6611 \cdot P4 + 0.4581 \cdot P7 + 0.6543 \cdot P9 - 0.7060 \cdot P11$$

- Moderate intensity cluster:

$$D = -3.5903 + 0.4405 \cdot P3 + 0.7048 \cdot P4 + 0.752 \cdot P8$$

- Low intensity cluster:

$$D = -0.6861 + 0.1509 \cdot P4 + 0.3554 \cdot P10$$

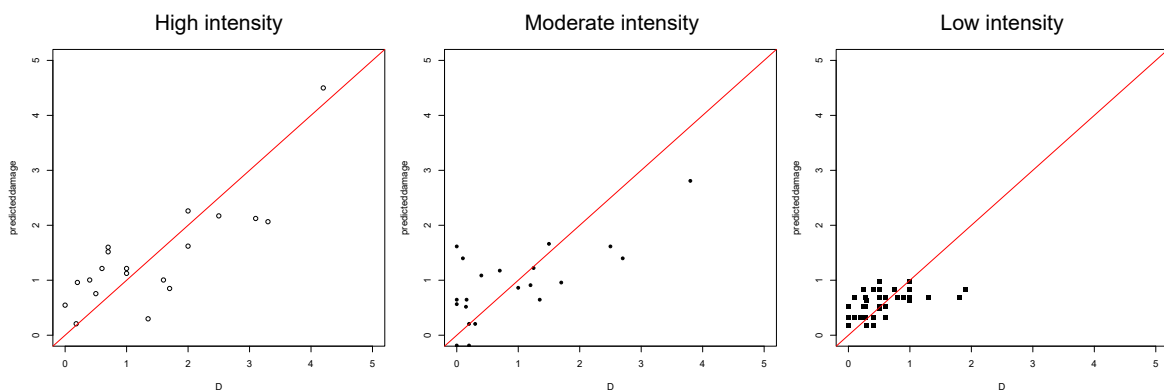

Charts 2-3-4. Predicted versus observed damage values for the respective clusters' regression models.

It is immediately evident that parameter P4, horizontal diaphragms, was a particularly relevant parameter in all three clusters. As regards the other parameters, however, some considerations must be made.

First of all, parameter P11, regularity in plan, did not show any relevance when evaluated with the formulas provided by GNDT and the Ferreira method. This result is not surprising considering the fact that the main feature of being long, slender buildings which tend to be the shape of a closed enclosure, at least for the set under examination, does not allow for the assessment of any real changes related to damage. Therefore, the classification by the number of intersections between existing wings was used.

Parameters P3, P7, P8, P9 and P10 (span, in-plane index, projections, presence of adjacent additions, plan) were of relevance in the clusters where a change in the parameter itself was actually found. For example, most of the cemeteries with projections are concentrated in the high intensity cluster, and cemeteries with high in-plane index, due to the absence of porch or significant structures are present in the medium intensity cluster.

However, regarding the parameter of the span, the presence within the same set of two completely different subsets, does not appear to be a parameter of particular relevance today. In fact, the former is characterised by the wheelbase of structures marked by niches, with specific variations from 2 to 6 metres, while the latter is completely unrelated to any organisation of space ranging from 10 to 30 metres and more. Indeed, in the case of



constructive uniformity of good quality (brick masonry), it is not possible to evaluate the vulnerability of the second subset as no damage from the overturning of the rear wall, the main criticality related to this parameter, occurred for this type of configuration.

This is in line with that stated in section 4.5, which identified the overturning damage to the rear wall as non-recurrent, due to the absence of any real damage to this type of configuration. In that case, the analysis of recurrence was postponed until further verification by enlarging the investigation clusters. In compliance with this decision, parameter P3 was not considered in the following elaborations, although it turned out to significant in one of the clusters.

Once the parameters were defined, an analysis of the standardized  $\beta$ -weights of the linear regression for all six remaining parameters was performed in each cluster. The aim was to assess the influence of each individual parameter in every cluster on the basis of the damage observed. Vulnerability index methods currently featured in literature, such as those discussed above, typically use parameter weights ranging from 0.25 to 1.50 in 0.25 intervals. In the case of the cemetery, the percentage influence of the  $\beta$ -weights for each parameter in every cluster was then associated with similar weights, with identification of the threshold, within the following range: 0 to 25%, 0.25; 25 to 50%, 0.5; 50 to 75%, 1; and 75 to 100% 1.5. From the analysis of the  $\beta$ -weights, it initially emerged that parameter P11 - regularity in plan, displayed a remarkable variation from negative to positive values. This means that the same vulnerability class could have both positive and negative effects, depending on the investigation cluster. Considering this, and considering that the parameter had not produced results for any of the validated methods recognised by the scientific community, as in the case of P3, the parameter was removed from the protocol for the cemetery vulnerability analysis under study. We then proceeded with the assessment of the five remaining parameters (Charts 5,6,7).

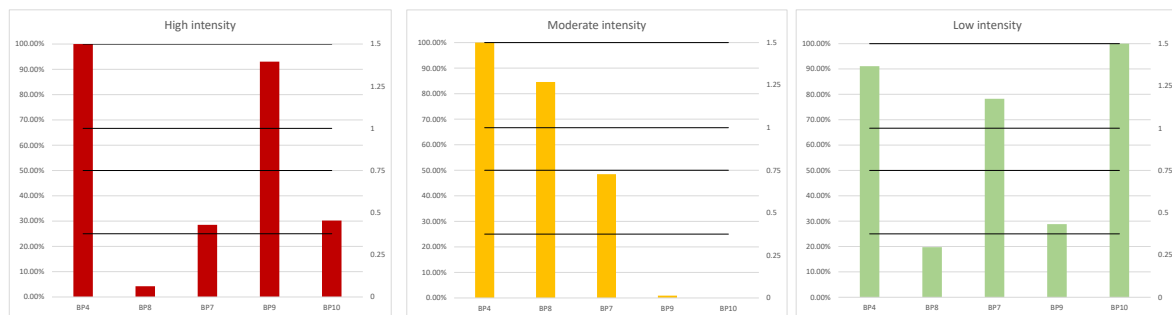

Charts 5-6-7. Percentage influence of beta weights in relation to weight assignment thresholds for the different clusters.

The values identified in each cluster through the  $\beta$ -weights were then compared and the final definition of the weights to be assigned to each parameter was reached.

	Weight in H	Weight in M	Weight in L	Final Weight (Pi)
P4	1.5	1.5	1.5	<b>1.5</b>
P8	0.25	1.5	0.25	<b>0.5</b>
P7	0.5	0.5	1.5	<b>0.75</b>
P9	1.5	0.25	0.5	<b>0.75</b>
P10	0.5	0.25	1.5	<b>0.75</b>

Lastly, the decision was made to add parameter P1, the construction quality of the vertical structures, to the protocol. This was of no significance relevance in the cluster

under examination, which was completely homogeneous for this parameter (Chart 1), as mentioned previously. In this case, regardless of the type of construction and function for which the structure is used, construction quality is a feature of fundamental importance in the vulnerability of buildings. Poor quality masonry can, in fact, lead, even before collapse due to seismic out-of-plane actions, to collapse due to disintegration of the masonry. As we cannot refer to any assessment for the cluster under investigation, we assume its weight in a conventional way, by assessing items already existing in literature:

	SVIVA	Benedetti-Petrini	Vicente	Ferreira-Vicente	Formisano	Final Weight (Pi)
P1	1.5	1.5	1.5	1.5	0.25	1.5

In conclusion, the parameters that form the basis of the operational protocol for the assessment of the Iv damage index for cemetery structures are:

P1: masonry quality

P4 - subsequently P2: type of horizontal diaphragms

P7 - subsequently P4: wall to wall connection

P8 - subsequently P3: in-plane index

P9 - subsequently P5: Non-structural elements

P10 - subsequently P6: Structural heterogeneity among adjacent building structures

The protocol for the identification of the Vulnerability Index Iv is therefore defined as follows:

Parameters	Vulnerability Class				Weight
	A	B	C	D	
P1 (ex P4) Type of Materials	0	5	25	50	1.5
P2 (ex P5) Horizontal diaphragmas	0	15	25	50	1.5
P3 (ex P7) In-plane index	0	5	25	50	1
P4(ex P8) wall to wall connection	0	5	25	50	1
P5 (ex p10) Non-structural elements	0	5	25	50	0.5
P6(ex P11) Structural heterogeneity among adjacent buildings	0	5	25	50	0.5

P1 - type of material	
A	Brick masonry of good quality, masonry in stone or tuff well squared, as long as homogeneous in all their extension. Good and homogeneous rubble masonry provided with connections between the two layers.
B	Masonry in brick, stone or tuff well squared but not homogeneous. Rubble masonry as long as it has connections between the two layers.
C	Roughly squared stone or brick masonry of poor quality, and not homogeneous; Rubble masonry, in tuff or stone, with a good brickwork but lacking of connections between the two layers.
D	Irregular stone walls; Brick walls of bad quality with inclusion of pebbles; Irregular sack walls and lacking of connections between the two layers.

P2 - Horizontal diaphragms	
A	Rigid diaphragms
B	Semi-rigid diaphragms such as SAP, reinforced slabs etc...
C	Flexible diaphragms or vault with tie
D	Vault without tie

P3 - in-plane index (Yi)	
A	$Y_i \geq 0.1$
B	$0.07 \leq Y_i < 0.1$
C	$0.03 \leq Y_i < 0.07$
D	$Y_i < 0.03$

P4 - wall to wall connection	
A	There were not additions in the cemetery
B	There were few and long additions in the cemetery
C	There were mixed long and little additions in the cemetery
D	There were a lot of little additions in the cemetery

P5 - Non-structural elements	
A	Absence of non-structural elements
B	Non-structural elements not present along the entire perimeter but built in a few limited portions of the cemetery: such as punctual pediments solution
C	Low attic solutions
D	High attic solution and projectin elements

P6 -Structural heterogeneity among adjacent Buildings structures	
A	The adjacent cemetery construction has a structural typology very different from that of the historical cemetery
B	The cemetery construction is adjacent to construction made of the same material but erected with a construction technique worse than the examined one
C	Aggregate cemeteries are homogeneous from typological and structural viewpoints
D	The cemetery is close to different parts made of the same material but erected with a construction technique better than the examined one

- **Correlation of the index application method to the macro-seismic method: definition of a vulnerability curve for cemeteries.**

The ultimate goal of any vulnerability assessment protocol is to correlate the estimated vulnerability index for a building ( $I_v$ ) with the expected damage for different seismic inputs. In this particular case, as previously stated, the objective is therefore to correlate the vulnerability index  $I_v$  defined through a method by scores with the analytical expression proposed by Giovinazzi and Lagomarsino for the evaluation of the average damage as the macro-seismic intensity varies:

$$\mu d = 2.5 \left[ 1 + \tanh \left( \frac{I + aV - b}{q} \right) \right].$$

In fact, this correlation allows an estimate of the expected damage for different values of the

Index as the seismic input, defined as macro-seismic intensity (I), varies. This is based on the relationship between Vulnerability Index (Iv) and Vulnerability (V) of the macro-seismic approach:

$$V = c + d * Iv$$

Several correlations are already existing in the literature. They are associated with the different methods of identifying vulnerability index as those analysed in the previous paragraphs even if they are always arranged for ordinary construction:

- Method Vicente (2008):  $\mu d = 2.5 \left[ 1 + \tanh \left( \frac{I+6.25V-12.7}{Q} \right) \right]$  ;  
con  $V=0.56+0.0064*Iv$ .
- Method Ferreira-Vicente:  $\mu d = 2.5 \left[ 1 + \tanh \left( \frac{I+6.25V-13.1}{Q} \right) \right]$  ;  
con  $V=0.592+0.0057*Iv$ .
- Method SVIVA:  $\mu d = 2.5 \left[ 1 + \tanh \left( \frac{I+6.25V-12.7}{Q} \right) \right]$  ;  
con  $V=0.46+0.012*Iv$ .

Therefore, among the correlations defined for the models used as reference for the evaluation of the parameters and aforementioned, a first evaluation was carried out to identify if there was a correlation also effective for the set under investigation, although the investigated buildings are very different. The result confirmed the need to make a new correlation for cemetery type. In fact, of the three methods described above, the closest to the observed damage is the SVIVA method, which, however, tends to overestimate damage as vulnerability increases (Chart 8).

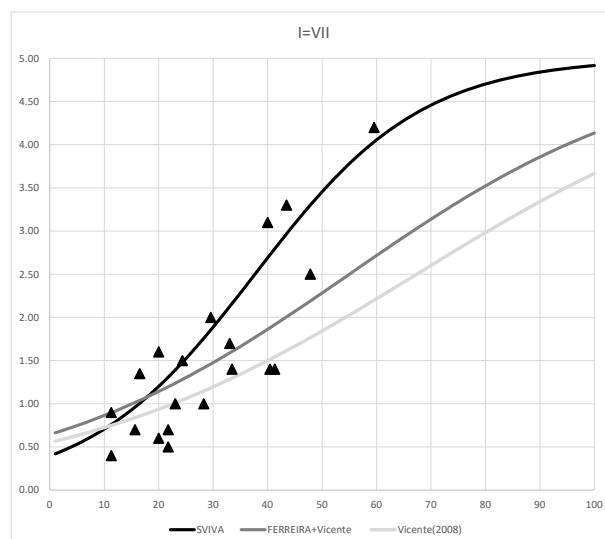

Chart 8. Buildings' Vulnerability curves from literature compared to cemetery data for the I=VII cluster.

Through the use of CurveExpert pro software, the four parameters (a,b,c,d) of formulas (1) and (2) presented above were identified. These parameters would identify the best vulnerability curve for the different macro-seismic intensities of the set investigated (Charts 9, 10, 11). Preliminarily, a value was also assigned to the Q parameter. This is an empirically defined

index that takes into account the ductility of a particular type of construction, and typically varies from 1 to 4. Normally, churches are associated with a value of 3 and buildings with a value of 2.3, but cases in which basic buildings have been associated with a value equal to that of churches are not uncommon. In the present research, due to the greater constructive proximity of columbaria to buildings more than to churches, the value used is the conventional one for buildings, i.e. 2.3.

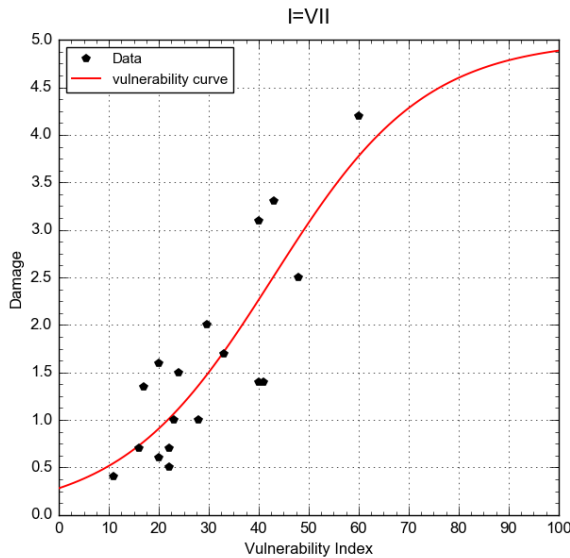

Chart 9. Vulnerability curve for the I=VII cluster.

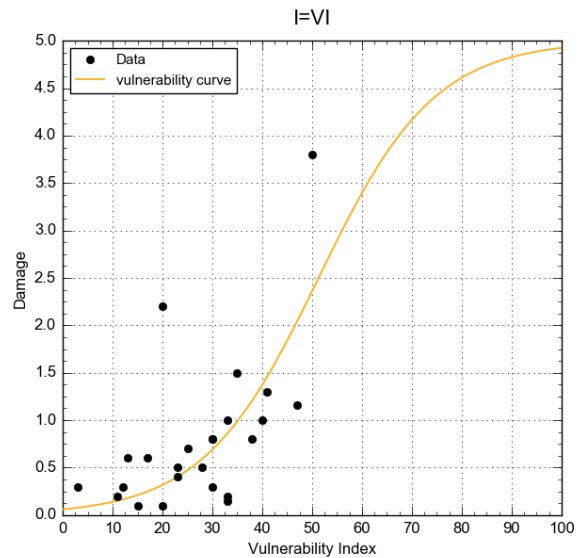

Chart 10. Vulnerability curve for the I=VI cluster.

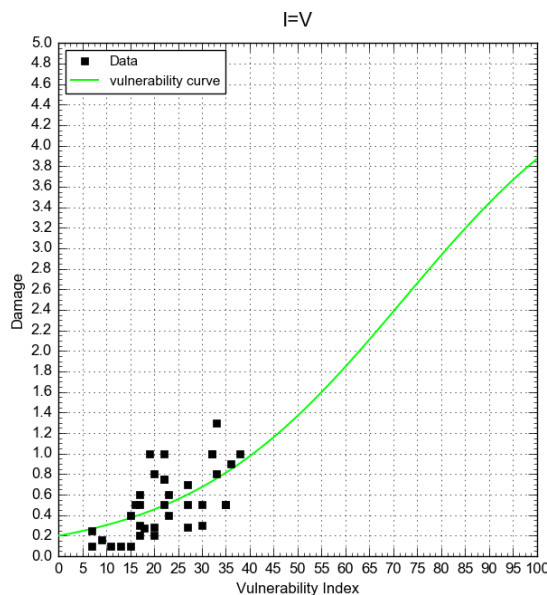
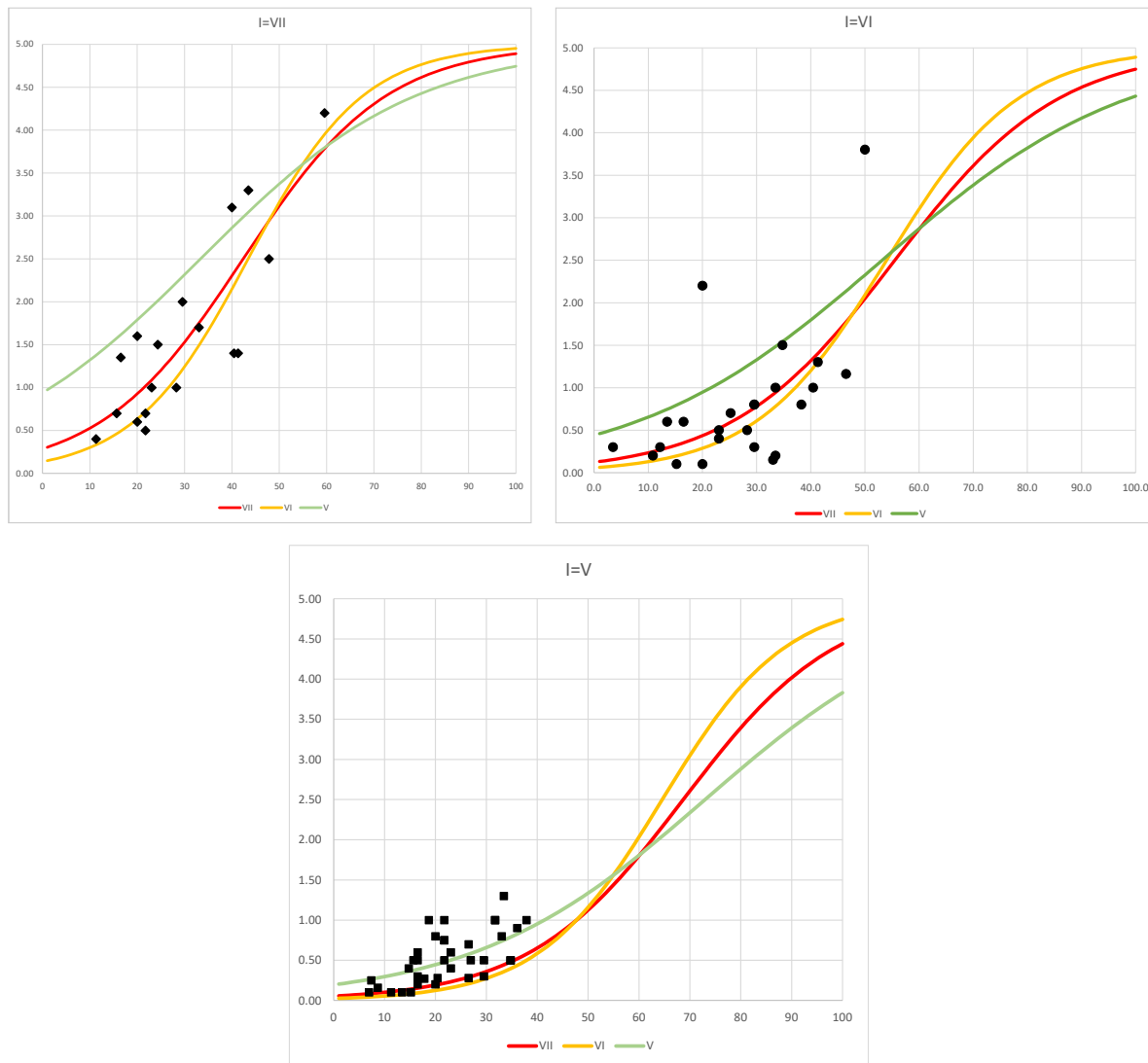

Chart 11. Vulnerability curve for the I=V cluster.

The three different formulations were then applied to the different macro-seismic intensities sets (Charts 12, 13, 14) in order to evaluate through the Mean Absolute Error which of them was able to better estimate all them, and consequently provide the best damage evaluation.

With MAEs of 0.47 in Chart 12, 0.38 in Chart 13, and 0.61 for Chart 14, it is the formulation identified for the cluster with macro-seismic intensity of VII that is the curve that best interprets all three clusters examined.



Charts 12-13-14. Comparison between the vulnerability curves obtained in the different cluster.

The final formulation for identifying expected damage therefore becomes as follows:

$$\mu d = 2.5 \left[ 1 + \tanh \left( \frac{I + 5.18V - 14.9}{Q} \right) \right]$$

$$\text{con } V = 0.93 + 0.0013 \cdot I_v.$$

This represents a very good interpretation of the expected damage for macro-seismic intensities 6 and 7 (Chart 15 and 16), while the expected damage for macro-seismic intensity 5 is slightly underestimated (Chart 17). It must be considered, however, that macro-seismic intensity 5 indicates a scarce if not almost null presence of damage on the territory. For this reason, in these cases, it is therefore more difficult to identify the damage entity.

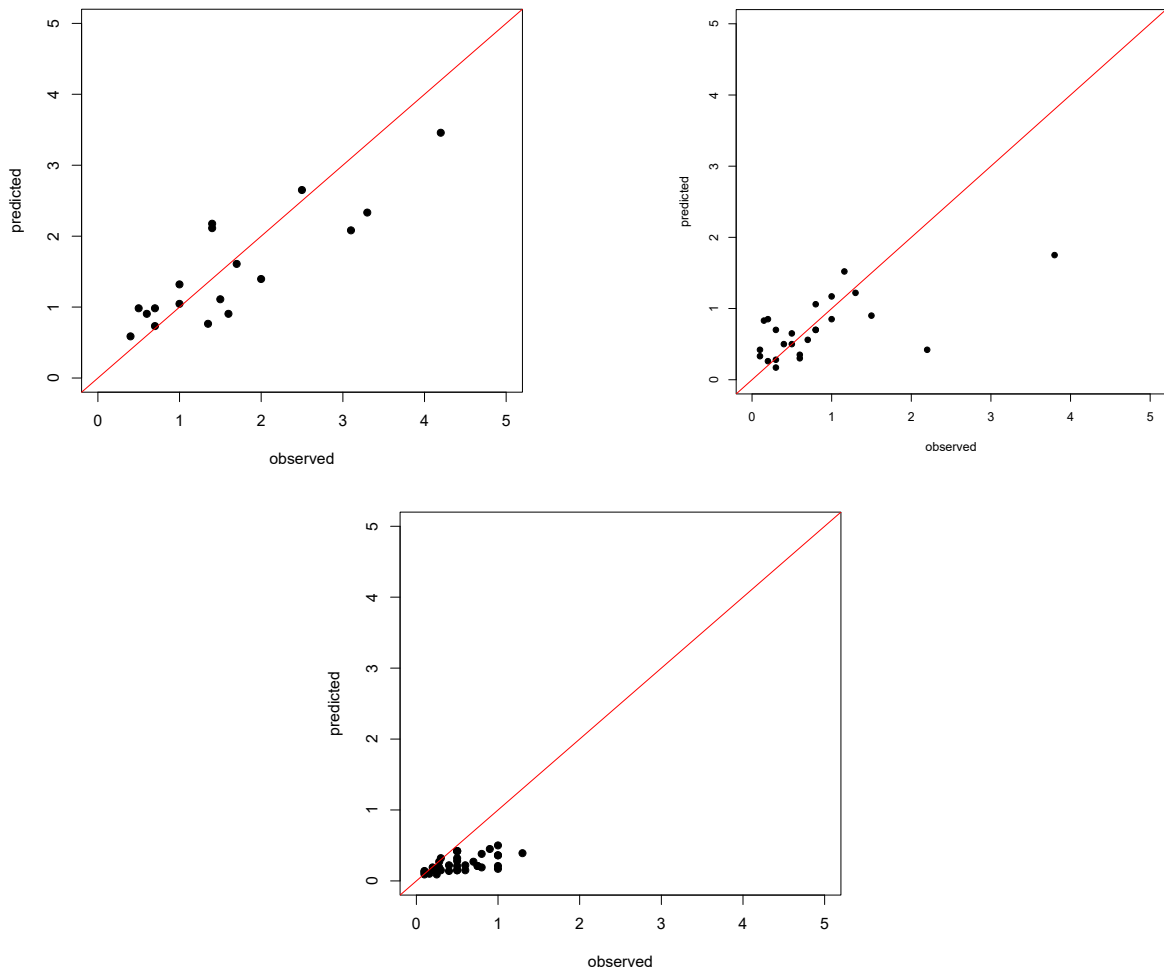

Charts 15-16-17. Ratio between predicted and observed damage in the relative clusters with the selected formulation.

## 5.4 Critical discussion of the data obtained

The results obtained for the identification of a protocol for the vulnerability assessment of cemeteries are to be considered only a first step towards the definition of a more general protocol that can also consider other parameters of analysis than those that emerged from this research.

Considering the complexity of the built reality and the relationships between structural elements, which can aggravate or reduce the damage, the identification of these protocols starting with the analysis of the observed damage is limited, and generally it relates to the identification of specialized buildings as churches or others (Lagomarsino & Podestà, 2005). To evaluate other buildings, a numerical approach is generally preferred. It is possibly validated in reality only in a subsequent phase.

Due to the specialized nature of the cemetery type and the high population of the investigated set compared to the total number of cemeteries present, the problem was approached first with the observed damage. Therefore, the analysis accepts the partial solution to the problem of the vulnerability survey of the cemeteries and to the forecast of the expected damage. It was therefore preferred to define a tool that would allow for a survey of damage and

vulnerability specifically studied in the type, although still limited. This result thus provides the basis for subsequent developments through the data implementation with other existing databases (Sisma Centro Italia 2016) or through the creation of a database specifically dedicated to cemeteries.

Initial vulnerability assessments from the investigated set are possible, but the associated limitations also make it impossible to define many parameters commonly considered in this type of analysis. Such limitations concern technological-constructive, geographical, numerical and damage aspects. In the first case, the limit is represented by the technological construction context, which is uniform with regard to certain features. It does not allow an understanding of the effect on the vulnerability due to, for example, roof structures or masonry quality. If the latter can be included in the protocol through the use of scientific literature, other aspects require further investigation. The geographical limit instead clearly refers to the ground conditions. The single geographic entity where cemeteries are built, the Po Valley, does not allow for the evaluation, for example, of the effects of slopes or ground type. Finally, the numerical and damage limits relate to the number of elements in the investigated set. In fact, although the result of about one hundred cemeteries is a good initial survey set, this set diminishes given a division into respective subsets by macro-seismic intensity. Additionally, cemeteries with very high damage indices are limited in number, even in relation to the presence of moderate vulnerability factors. This limitation makes it difficult to understand the relationship between the damage that has occurred and the parameters analysed.

All this has led to the formulation of a vulnerability index through only six parameters and to the definition of vulnerability curves calibrated on buildings which can be considered regionally uniform. The result should therefore be considered as only a first step towards the definition of a more complete and accurate protocol and vulnerability curves that more suitably represent all the cemeteries within the Italian territory. This first step can be taken through the implementation of data on damaged cemeteries derived from other contexts, such as that of the 2016 Central Italy Earthquake or other seismic events in future