

Elsevier Editorial System(tm) for Building  
and Environment

Manuscript Draft

Manuscript Number: BAE-D-17-00079R2

Title: Impact noise of timber floors in sustainable buildings

Article Type: Original Research Paper

Keywords: Sustainable timber buildings; acoustic; impact sound  
insulation; precast energy saving panels

Corresponding Author: Dr. Marco Caniato,

Corresponding Author's Institution: University of Trieste

First Author: Marco Caniato

Order of Authors: Marco Caniato; Federica Bettarello, Dr.; Patrizio  
Fausti, Prof. Dr.; Alessio Ferluga; Lucia Marsich, Dr.; Chiara Schmid,  
Prof. Dr.

Abstract: Timber building represents a robust alternative to traditional  
heavyweight constructions. They allow CO2 storage, high structure and  
performance reproducibility, fast assembly and final certification of  
every panel.

Nowadays, acoustic insulation is one of the most requested performances  
on the part of inhabitants, but not always fulfilled. Since these kinds  
of edifice are relatively new in the market, there are very few studies  
on acoustic properties, focusing on impact sound performances. In this  
paper, an in-depth analysis of impact noise on bare timber floors is  
presented, focusing on how impact sound reduction cannot be as efficient  
as in heavyweight constructions. Two new equations are proposed,  
modelling the impact sound pressure level of common bare timber  
structures and the influence of traditional floating floor systems is  
analysed.

## Impact sound of timber floors in sustainable buildings

M Marco Caniato<sup>1,3,\*</sup>, Federica Bettarello<sup>2</sup>, Patrizio Fausti<sup>3</sup>, Alessio Ferluga<sup>1</sup>, Lucia Marsich<sup>1</sup>, Chiara Schmid<sup>1</sup>

<sup>1</sup> Engineering and Architecture Department, University of Trieste, via Valerio 6/a, 34127 Trieste, Italy

<sup>2</sup> AcusticaMente Designers Team, via Garibaldi 13/b, 31015 Conegliano (TV), Italy

<sup>3</sup> Department of Engineering, University of Ferrara, via Saragat 1, Ferrara, Italy

\* corresponding author: [mcaniato@units.it](mailto:mcaniato@units.it):

The acoustics of timber buildings is one of the big unsolved issue related to lightweight constructions. Focusing on impact sound pressure level, the behaviour of bare floors was not studied so far. This lack in the acoustic field research is of paramount importance since it was not possible to predict acoustic behaviour of timber buildings. As a matter of fact, the prediction does take into account the frequency trend behaviour of the bare structure. These values are present in literature and standards for traditional heavyweight constructions (masonry, concrete,...) but not for timber ones

The aim of this work is to deeply investigate the frequency trend of impact sound pressure levels of crosslam and glulam timber floors and to finally provide a robust analytical model usable for the prediction of impact noise reduction.

The authors declare that the work described has not been published previously (except in the form of an abstract or as part of a published lecture or academic thesis or as an electronic preprint), that it is not under consideration for publication elsewhere, that its publication is approved by all authors and tacitly or explicitly by the responsible authorities where the work was carried out, and that, if accepted, it will not be published elsewhere in the same form, in English or in any other language, including electronically.

The authors declare that there are no scientific or financial conflicts of interest related to other papers.

The authors also confirm that any necessary permissions have been obtained.

Reviewer 5

Reviewer's comment	Authors' feedback
<p>You said "The present ISO 12354-2 concerning the concrete bare slab impact noise was made using only 6 or 7 measurement". This weakness in the standard is well-known and it is not a methodological justification. For this reason is highly recommended to report explicit references to the accuracy of the data-set. About this topic, your answer "The graphs from 5 to 9 (old 8.3) are very useful to demonstrate the repeatability and reproducibility of the measurements both in frequency and in single number." is unsatisfactory because it does not provide explanations on the dispersion of individual data, mainly at low frequency. In this case a plot of all the individual measured sound pressure values with +/- 2 stdev value span is more useful and clear. An example of this type of data representation can be found in your reference [3].</p>	<p>Thank you for your suggestion.</p> <p><u>We added</u> (fig.21) the individual dispersion of data with +/- 2 stdev value span.</p>
<p>You said "No flanking transmission evaluation was performed since there is no need to measure or evaluate them concerning the aims and goals of this study. These kind of buildings won't be finished on the bare structure for fire resistance and thermal insulation issues. So always additional layers such as plaster or fibreboard with hollow spaces filled with porous materials are used in every wall. These added layers greatly modify flanking transmissions. For these reasons real and final flanking transmissions values will surely change from the "bare" situation to the "final" one. The aim of this paper, as stated in the introduction, is to evaluate the L'n,0 of glulam or Cross Laminated Timber bare floor and not to evaluate their possible and bare flanking transmission." This is clear, but as suggested at the beginning, the reference to flanking transmission evaluation (not necessarily measured) have to be considered also for the bare structure. Is well-known by laboratory tests that the CLT element connection method affect the radiation efficiency of the bare structure and that this behavior can be evidenced by measuring the vibration reduction index.</p> <p>Please, for this topic refer to L. Barbaresi, F. Morandi, M. Garai, A. Speranza, Experimental measurements of flanking transmission in CLT structures, Proc.</p>	<p>Thank you for your suggestion.</p> <p>The topic reference (Barbaresi et. al) you suggested was published 4 or 5 days before we received these comments. It correctly suggests what you highlights: "CLT element connection method affect the radiation efficiency of the bare structure". This is basically due to the fact that in laboratory all the mounting tolerances are very controlled. But the in situ situations will be surely different since there is no control in mounting tolerances and very different screws or angle brackets could be used. Nevertheless, the same authors (Barbaresi et. al) conclude (section B of the paper) that:" If all the differences were due to the mounting tolerances, one could draw the conclusion that in situ realizations will provide a more uniform behavior among the panels due to the greater number of constraints". In other words in situ realization are less affected by fastening systems, since they are more rigid. This conclusion was also deeply discussed and investigated directly with the authors before writing this reply.</p> <p>This fact is strengthened by our measures since from the mass ratio point of view, in our case flanking walls were various: CLT or GLT ones. Referring to</p>

<p>Mtgs. Acoust. 28, 015015 (2016). doi: <a href="http://dx.doi.org/10.1121/2.0000433">http://dx.doi.org/10.1121/2.0000433</a>. The point is that, basically, the validity of the formulas you propose is limited by the assumption of similar connection conditions between the structures. To extend the results of your data to other types of connections between nude structures also this aspect have to be considered.</p>	<p>table 2 this did not seem to affect the final single number results. This fact could lead to a preliminary conclusion that if the flanking walls are lighter than the CLT floor, then the influence of CLT and GLT difference could be very low.</p> <p>As a matter of fact prISO12354-2 does not include mixed structures evaluations since in section F.4.2.1 concerning the GLT technology the crosslam one is explicitly excluded. The topic of flanking transmissions in CLT-CLT constructions is implemented within pr ISO 12354-1, where in Annex F, fig. 2, a possible formulation is provided, basically taken from Guigou-Carter C., &amp; Villot M. Junction characteristics for predicting acoustic performances of lightweight wood-based buildings, Proceedings Internoise San Francisco 2015. Here, no influence of the screwing or bracketing systems is described or requested, because it is almost impossible for designers to forecast how many fastening system will be used and of which type, diameter or length.</p> <p>Concluding we really thank you for your brilliant comment which gave us the opportunity to better focus and deeply analyse this very important topic, contacting directly the authors of the new reference and discussing possible explanations with them. Your conclusion that our equation extension depends on similar flanking transmission is correct and true and <u>we included this consideration in the text</u>. But we could be pretty sure that different flanking possible transmission present in real field constructions will be similar to the ones we found in our study. Further investigation will hopefully confirm our hypothesis.</p> <p><u>We now included</u> a dissertation on flanking transmissions in the text and <u>we add your consideration</u> on possible extension of our formula, <u>according to your comment</u>.</p>
<p>--- In section 2.1 you said "... all tests were carried out according to ISO 16283-2 using eight measures per room. As a confirmation all tests were repeated according to ISO 10052 which always validated previous ones."</p> <p>How can a survey method (ISO 10052, less accurate) be used to validate a technical method (ISO 16283, more accurate)?</p> <p>In a similar study the accuracy difference between ISO 16283 and ISO 10052 was pointed out. Please refer to R. Scoczynski Ribeiro, A. Matoski, M.H. de Avelar Gomes, C.A. da Costa; R.E. Catai, The acoustic performance of walls</p>	<p>Thank you for your suggestion.</p> <p>The conclusions reached by Ribeiro et al. was found by some of the authors too (Caniato M., Bettarello F., Baccan V., "La misura degli indici R'w, L'nw e D2mntw: confronto in opera tra i metodi proposti dalle norme UNI EN ISO 140 e UNI EN ISO 10052 ", Proceedings of Italian acoustic association congress, Roma (Italy) 4-6 July 2012, <b>in italian</b>) but only for the façade index <math>D_{2m,nT,w}</math>. This is due to the fact that it is very difficult to understand the position of the</p>

<p>made with sustainable and industrialized panels, Proceedings of ICA, 2016, Buenos Aires.</p>	<p>measurer in the room since the façade wall could be complex and often it is not one single wall but could be composed of more than one partitions in different directions (corner walls, etc.).  For the other parameters (<math>R'_w</math> and <math>L'_{nw}</math>) we basically found almost the same results using 10052 (arms hold rotating sound level meter) and 16283 (fixed points), both in single index and frequency domain.  This fact is confirmed by the new ISO 16283-1 which basically includes the ISO 10052 method. The manual-scanning path type 1 (circle) is very similar to ISO 10052 method. It is based on HOPKINS, C. On the efficacy of spatial sampling using manual scanning paths to determine the spatial average sound pressure level in rooms. Journal of the Acoustical Society of America , 2011, 129(5), pp. 3027-3034. Reference <u>was added</u>.  However, the measurements were performed both using fixed microphones positions and manual-scanning path type 1 (circle). Frequency results were almost coincident, so final values are reliable and robust.  In order to clarify this topic, reference to ISO 10052 <u>was deleted</u> and <u>a sentence was added</u> to better explain this topic, <u>according to your comment</u>.</p>
<p>Despite there are no strict requirements on reference formatting at submission, is recommended to follow the reference style described at page 12 of the BaE Author Information Pack. Please, check carefully.</p>	<p>Thank you for your suggestion.   <u>All reference were re-edited</u></p>
<p>As declared by the authors in the abstract, ref. [60] is the revised and improved version of ref. [52]. Please, replace the oldest with the updated one and, consequently, report the correct reference in figure 23.</p>	<p>Thank you for your suggestion.   In the oldest version was focused only on bare floors. In the 2016 one, as declared by authors, they used the bare floors values to investigate the floating floor influence on hybrid CLT.  For these reasons, we prefer to maintain the two different and separated citations since the first is related only to impact noise of CLT floors while the second one is related to hybrid CLT floors also investigating floors influence.</p>
<p>Some references are incorrectly reported, incomplete or outdated. Please upgrade this references as follow:  [25] COST Action FP0702. Net-Acoustics for Timber based lightweight buildings and elements e-book, available at <a href="http://extranet.cstb.fr/sites/cost/ebook/">http://extranet.cstb.fr/sites/cost/ebook/</a>, accessed on ... (check it and update)  [50] A Di Bella, N. Granzotto, L. Barbaresi, Analysis of acoustic behavior of</p>	<p>Thank you for your suggestion.   <u>All reference were updated</u></p>

<p>bare CLT floors for the evaluation of impact sound insulation improvement, Proc. Mtgs. Acoust. 28, 015016 (2016). doi: <a href="http://dx.doi.org/10.1121/2.0000420">http://dx.doi.org/10.1121/2.0000420</a></p>	
<p>There are also some typing errors in the references: Typo in ref. [7]: replace the full stop with the comma after the author's name. Typo in ref. [18]: there are two commas after the name of the first author. Typo in ref. [46] and [56]: please, shorten the names of the authors as usual (and use replace the semicolon with the comma). Typo in ref. [37] and [49]: please, reverse the position of the author's name.</p>	<p>Thank you for your suggestion.</p> <p>All reference <u>were updated and typos were fixed</u></p>

## **Impact sound of timber floors in sustainable buildings**

M Marco Caniato<sup>1,3,\*</sup>, Federica Bettarello<sup>2</sup>, Patrizio Fausti<sup>3</sup>, Alessio Ferluga<sup>1</sup>, Lucia Marsich<sup>1</sup>, Chiara Schmid<sup>1</sup>

<sup>1</sup> Engineering and Architecture Department, University of Trieste, via Valerio 6/a, 34127 Trieste, Italy

<sup>2</sup> AcusticaMente Designers Team, via Garibaldi 13/b, 31015 Conegliano (TV), Italy

<sup>3</sup> Department of Engineering , University of Ferrara, via Saragat 1, Ferrara, Italy

\* corresponding author: [mcaniato@units.it](mailto:mcaniato@units.it);

### **Highlights**

- The influence of the bare timber structures was analysed related to impact noise
- Several in situ measurements of bare timber floors were performed
- For crosslam bare floor a new frequency model is proposed for impact noise
- For glulam bare floor a new frequency model is proposed for impact noise
- A comparison with traditional heavyweight structures is provided

## Impact noise of timber floors in sustainable buildings

Marco Caniato<sup>1,3,\*</sup>, Federica Bettarello<sup>2</sup>, Patrizio Fausti<sup>3</sup>, Alessio Ferluga<sup>1</sup>, Lucia Marsich<sup>1</sup>, Chiara Schmid<sup>1</sup>

<sup>1</sup> Engineering and Architecture Department, University of Trieste, via Valerio 6/a, 34127 Trieste, Italy

<sup>2</sup> AcusticaMente ~~Engineering consulting~~Designers Team, via Garibaldi 13/b, 31015 Conegliano (TV), Italy

<sup>3</sup> Department of Engineering, University of Ferrara, via Saragat 1, Ferrara, Italy

\* corresponding author: [mcaniato@units.it](mailto:mcaniato@units.it); +39347316728; FAX +39 040 558 3836

Formatted: Indent: Left: 0.59 cm, Hanging: 0.16 cm

Field Code Changed

### Abstract

Timber buildings represent a robust alternative to traditional heavyweight constructions. They allow CO<sub>2</sub> storage, high structure and performance reproducibility, fast assembly and final certification of every panel.

Nowadays, acoustic insulation is one of the most requested performances on the part of inhabitants, but not always fulfilled. Since these kind of edifices are relatively new in the market, there are very few studies on acoustic properties, regarding on impact sound performances. In this paper, an in-depth analysis of impact noise on bare timber floors is presented, focusing on how impact sound reduction cannot be as efficient as in heavyweight constructions. Two new equations are proposed, modelling the impact sound pressure level of common bare timber structures and the influence of traditional floating floor systems is analysed.

Keywords: Sustainable timber buildings; acoustic; impact sound insulation; precast energy saving panels

### 1. Introduction

Lightweight precast timber buildings are present worldwide and their market trend is growing, since the related thermal insulation performances provide very good final results. They allow CO<sub>2</sub> storage, since wood is widely used, as it is a renewable and environmentally friendly raw material and commonly a very good thermal insulation is provided thanks to traditional [1] and new materials [2] use. Generally, these constructions are built within industry plants where costs are minimised beforehand and where it is ensured that as little waste as possible is produced, according to Kyoto protocol purposes [3].



Furthermore, prefabrication often means high repeatability since specialised workmanship is used, including CAD-CAM technologies, permitting new and complex architectural shapes, concepts and tendencies. In addition, the final product needs CE certifications, so as to ensure quality.

Nevertheless, acoustic performances are not always at the top range. For example, impact noise in timber constructions is the most common cause of complaint on the part of inhabitants [4], because in this kind of lightweight buildings the usual impact reduction methods would not properly work.

In fact, in traditional heavyweight buildings high density solutions are often used in order to reduce the impact sound pressure level [5]-[8]; the standard ISO 12354-2 [9] includes the analytical model as reported in equation (1):

$$(1) \quad L_n = L_{n,0} - \Delta L \quad (\text{dB})$$

where  $L_n$  is the resulting impact noise (dB),  $L_{n,0}$  is the impact noise of the bare floor (dB),  $\Delta L$  is the impact sound pressure level reduction (dB).

It is evident that the bare floor acts as starting point and so the type of partition is the primary source.

The floating floor is one possible solution for the reduction of the impact sound pressure level using the mass-spring-mass effect based on Cremer's theory [10]. This method is widely used and successfully applied from the design process to the realization of the building.

The floating floor is nowadays one of the best and safest solution to reduce impact noise in heavyweight constructions. It includes a heavy bare floor, a resilient layer and a heavy upper slab; the analytical method is reported in equations (2) and (3).

$$(2) \quad \Delta L = 30 \log(f/f_0) \quad (\text{dB})$$

where  $\Delta L$  is the impact sound pressure level reduction (dB),  $f$  is the frequency [Hz] and  $f_0$  is the resonance frequency [Hz] of the spring-mass system expressed by

$$(3) \quad f_0 = (1/2\pi)\sqrt{(s'/m')} \quad [\text{Hz}]$$

where  $s'$  is the apparent dynamic stiffness per unit area [ $\text{MN}/\text{m}^3$ ] and  $m'$  is the mass per unit area of the massive slab [ $\text{kg}/\text{m}^2$ ].

As a matter of fact, the floating floor depends on the density of the upper slab and on the dynamic stiffness value of the resilient material [11] - [13] as explicated in equation (2) and (3). So what may change the final results is the bare floor impact noise trend. Furthermore, the reduction provided by the floating floor is not constant in the frequency domain [14]-[17].

In recent years many researchers have tried to deal with these new topics, stating that in particular the lightweight timber floors do not behave as the heavyweight ones [18]-[24]. Many project were developed; COST action FP90702 [25] reports that the wooden structures present a better insulation in middle and high frequency range than the heavy weight ones. As a consequence, the low frequency influence has to be further investigated.

Silent Timber Building project developed many tools and databases focusing on SEA calculation and prediction (as an example see [26] - [28]); this topic was also studied in independent researches (as an example see [29] - [31]) demonstrating the high interest on this type of constructions.

Many measurements were performed in years on different complete structures and an on line database was created [32]. Nevertheless, no bare structures is indexed in it.

All these studied reports similar initial or general results: timber structures are various and even if they are very repeatable, there are several differences between one producer to another.

Furthermore, applying the same prediction methods or analysis used for heavyweight constructions could yield rather approximate results. Recent studies [33]-[34] show how different bare floors (heavyweight concrete slab, beams and pots and lightweight timber concrete ones) present dissimilar impact sound pressure levels and consequently floating floor sound reduction could not ensure same results [35].

Nowadays the progress of modern constructions more and more includes lightweight buildings. At present 6 edifices out of 100 are erected using timber constructions in Europe [36]; in Japan the enforcement of the Act for Promotion of use of wood in Public Buildings pushed this technology to grow rapidly [37]. They provide many advantages like speed of assembly, industrial quality, reduction of workmanship errors, fast realization of difficult shapes, high integration of service equipment and windows [38].

The presence of timber buildings has grown in Europe since recent directive of the European Parliament [39] encourages the realization of new high performance buildings.

Different technologies are available but two types are most used: glulam beams with top boards (GLT) or cross-laminated timber panels (CLT). For both of them no standard or international literature provide a theoretical or empirical  $L_{n0}$  or frequency trend values in order to predict bare floors impact noise. This is the primary input data since the designing process is based on ISO 12354-2 [9] and Cremer's theory [10].

Especially at low frequency range (the more disturbing and annoying one [40]-[46]), this excitation is difficult to model because of two causes:

- i. the typologies of glulam beams with top boards are various; this fact decelerates possible researches and makes them very difficult;
- ii. the traditional models do not work with lightweight structures.

In this work, an in-depth study of the impact noise performance of bare timber floors is carried out, focusing on the results of in situ measurements. The aim of this paper is to provide empirical equations characterising the frequency behaviour trend, showing how different panels provide very similar performance and investigating the floating floor influence on impact noise reduction.

In appendix A, a list of abbreviation is provided.

## 2.1 Materials and methods

Timber floors are of various kinds, but could be divided into two categories: continuous and periodic. The first one is realized using different planks glued together until the final desired thickness is reached. The second possibility is to use glulam beams where, on top of them, boards (gypsum fibreboards, plasterboards, wooden chipboards, etc.) are secured using screws or nails.

These two kinds of structure were analysed using in situ impact noise measurements with an ISO tapping machine in multi-storey full-scale buildings. All rooms were closed using double plaster board panels or doors when available, in order to define single volumes; all tests were carried out according to ISO 16283-2 [47] using fixed microphones method with eight measures per room. ~~As a confirmation a~~All tests were repeated according to ~~ISO 10052 [48] manual-scanning path technique (type 1, circle)~~[48] which always validated previous ones. ~~In the first case, A~~all measures were performed using a ISO tapping machine for 20 second each and were repeated twice. The resulting averages were used in this study.

No flanking transmission evaluation was performed since there is no need to measure or evaluate them concerning the goals of this study. These kind of buildings won't be finished at the bare structure step for fire resistance and thermal insulation issues. So always additional layers such as plaster or fibreboard with hollow spaces filled with porous materials are used in every wall. For these reasons final flanking transmissions values will change from the "bare" situation to the "final" one [49], [50].

In all figures of similar type (from fig. 5 to 9, for fig. 13 and from fig.17 to fig.21) the y-axys represent the  $L'_{n,T}$  measured or calculated levels.

## 2.2 Cross laminated structure

The tested building was a four-storey construction (~~Figure 1~~~~Figure 1~~~~Figure 1~~) where 16 floors were measured (~~Figure 2~~~~Figure 2~~~~Figure 2~~) on 16 different receiving rooms. General data of the bare buildings are reported in ~~Table 1~~~~Table 1~~~~Table 1~~.

The panels were consisted of 7 cross overlapping layers providing a final thickness of 25 cm. The floor assembly was secured using a board fixed with screws and glue between panels or external walls (see ~~Figure 3~~~~Figure 3~~~~Figure 3~~). A high density elastomeric material was included in wall-floor junctions (see ~~Figure 4~~~~Figure 4~~~~Figure 4~~). In dwelling 4B no internal partition was present, so it could be considered as a "single room" apartment (133.5 m<sup>3</sup>).

Formatted: Font: 11 pt

Formatted: Font: 11 pt

Formatted: Font: 11 pt

Formatted: Font: 11 pt

Formatted: Font: 11 pt, English (United Kingdom)

Formatted: Font: 11 pt, English (United Kingdom)

Formatted: Font: 11 pt, Not Bold

Formatted: Font: 11 pt, Not Bold

Formatted: Font: 11 pt, Not Bold

Formatted: Font: 11 pt, Not Bold



Figure 1 - multi-storey Cross Laminated Timber building

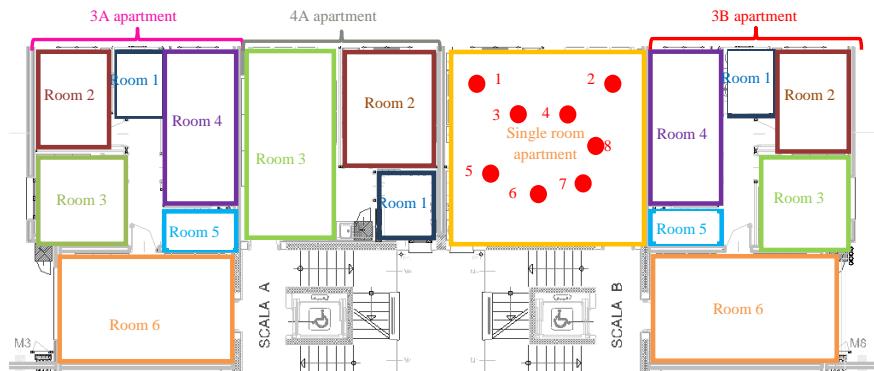

Figure 2 – standard floor map. For 3A, 4A and 3B apartments room specification are highlighted. For single room apartment measurement positions are marked, as example

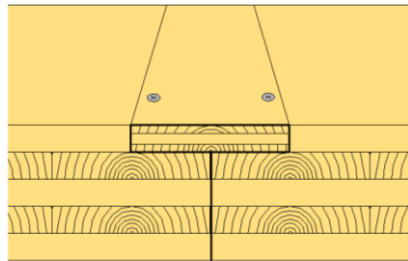

Figure 3 – floor assembly detail

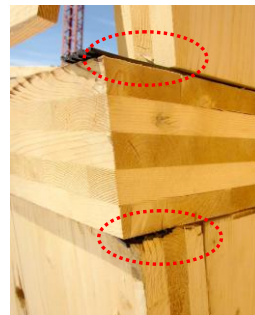

Figure 4 – wall-floor junction detail with elastomeric layer

Table 1 – General Cross Laminated Timber building data

Conditions of the partitions	Bare Cross Laminated Timber on all surfaces
Room 1 3A/3B apartment	10 m <sup>3</sup>
Room 2 3A/3B apartment	38.2 m <sup>3</sup>
Room 3 3A/3B apartment	35.6 m <sup>3</sup>
Room 4 3A/3B apartment	36 m <sup>3</sup>
Room 5 3A/3B apartment	8.1 m <sup>3</sup>
Room 6 3A/3B apartment	60 m <sup>3</sup>
Apartment 4B	133.5 m <sup>3</sup>

### 2.3 Cross laminated results

Figure 5 and Figure 6 show the results of impact noise measurements for apartments 3 A and 3 B at the frequency ranges 1000 Hz – 5000 Hz and 100 Hz – 800 Hz respectively. For these frequency ranges, final values are not influenced by the receiving room dimensions or tapping machine positions, thus indicating a great evenness of precast panels.

Formatted: Font: 11 pt, Not Bold

Formatted: Font: 11 pt, Not Bold

Formatted: Font: 11 pt, Not Bold

Formatted: Font: 11 pt, Not Bold

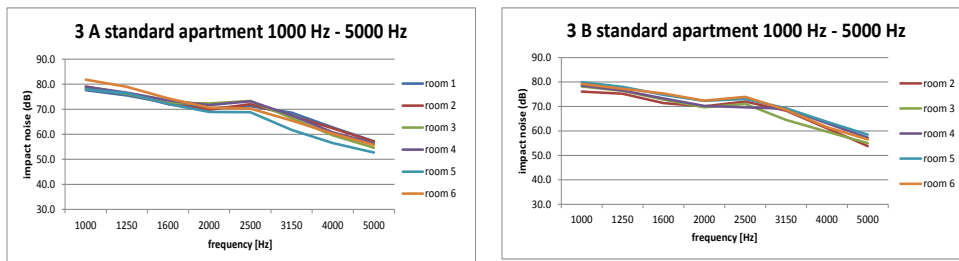

Figure 5 –high frequency trends for impact noise in apartments 3A and 3B.

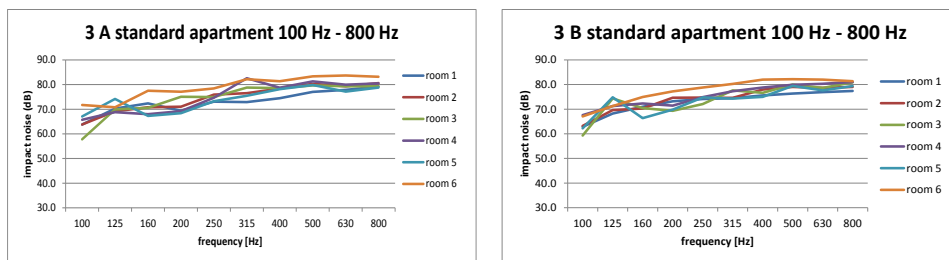

Figure 6 – middle frequency trends for impact noise in apartments 3A and 3B.

In the low frequency range (50 Hz÷80 Hz) impact noise level results could vary a lot especially in small rooms, as expected (Figure 7).

Formatted: Font: 11 pt, Not Bold

Formatted: Font: 11 pt, Not Bold

The same trends were found in the single room apartment (Figure 8 and Figure 9) where no appreciable difference was evidenced for middle and high ranges while for low frequencies no common behaviour is demonstrable.

Formatted: Font: 11 pt, Not Bold

Formatted: Font: 11 pt, Not Bold

Formatted: Font: 11 pt, Not Bold

Formatted: Font: 11 pt, Not Bold

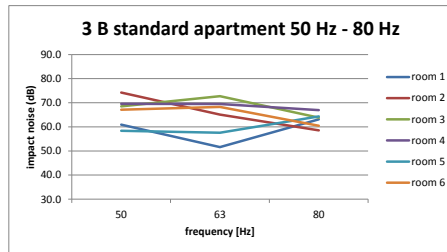
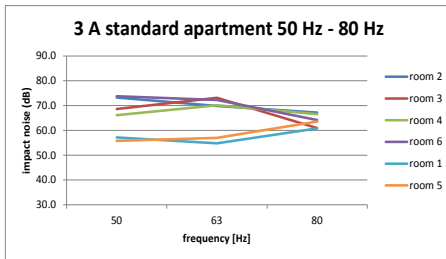

**Figure 7 – low frequency trends for impact noise in apartments 3A and 3B**

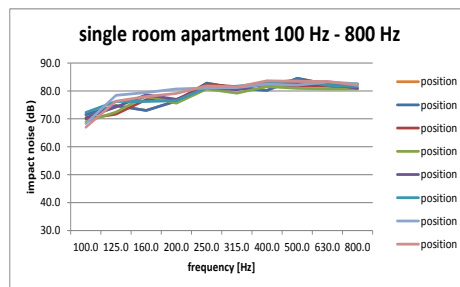
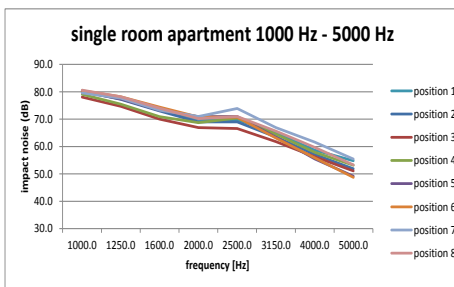

**Figure 8—trends for impact noise in single room apartment: high frequency and middle frequency**

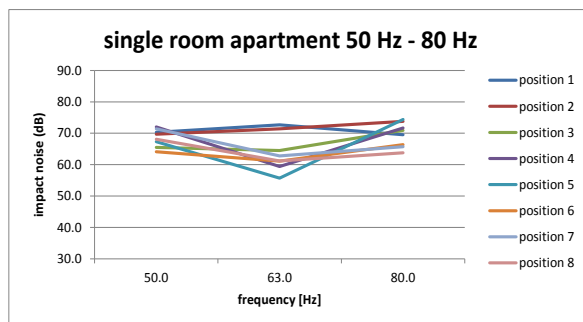

**Figure 9—trends for impact noise in single room apartment: low frequency**

For all the measured floors, the normalized impact sound pressure level provides a similar linear trend in the 1000 Hz÷5000 Hz range with a little variation around 2500 Hz (Figure 10Figure 10Figure 10).

In the 500 Hz – 800 Hz range the behaviour is quite similar but the level difference is quite higher. Under this threshold, a common trend with high level variations until 100 Hz is recognisable. In the lower range no common tendency is assessable.

Formatted: Font: 11 pt, Not Bold

Formatted: Font: 11 pt, Not Bold

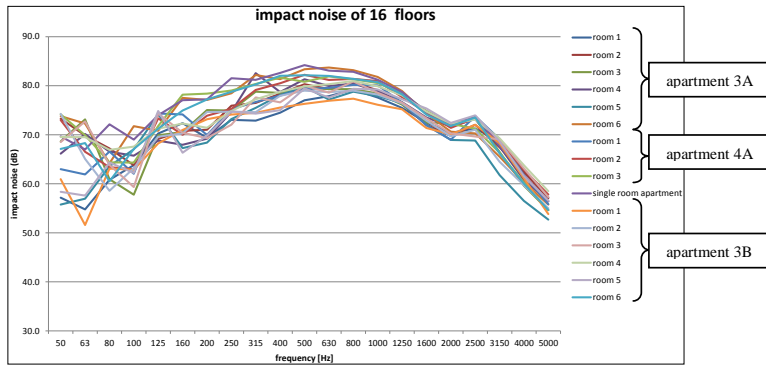

Figure 10 –frequency trends for impact noise of 16 floors

The increase in frequency at about 2500 Hz could be ascribed to the resonance caused by the ISO tapping machine laid directly on the wooden floor [17].

In order to compare only single index results, the weighted sound reduction index  $L'_{n,w}$  determined with ISO 717-2 method [51] as well as  $C_{1,50-2500}$  factor were calculated (Table 2). It is possible to understand once more that the single number differences are caused by low frequency range.

Formatted: Font: 11 pt

Formatted: Font: 11 pt

Table 2 – normalized impact sound pressure index values and  $C_{1,50-2500}$  factor for Cross Laminated Timber bare floors of every tested room. Similar room are compared.

Apartment 3A	$L'_{n,w}$	$C_{1,50-2500}$	Apartment 3B	$L'_{n,w}$	$C_{1,50-2500}$
room 1	79	-7,6	room 1	78	-7
room 2	79	-5,6	room 2	79	-6,3
room 3	80	6,6	room 3	80	-6,9
room 4	80	5,7	room 4	81	-7
room 5	78	-5,8	room 5	80	-7,3
room 6	81	-4,3	room 6	81	5,3

## 2.4 Glulam beams with top boards structure

The tested building was a three – storey construction where floors were tested on different receiving rooms (Figure 11 and Figure 12). Panels were constituted of glulam beams (18 cm thickness) connected with wooden chipboard screwed on top of them (2.2 cm thickness), mineral wool between them (10 cm thickness, 55 kg/m<sup>3</sup> density) and laterally fastened with wooden closures (Figure 13). These panels are laid in order to match the external border, so it was possible to find an air gap between them. This was filled using high sound insulation foam (Figure 14).

Formatted: Font: 11 pt, Not Bold

Formatted: Font: 11 pt, Not Bold

Formatted: Font: 11 pt, Not Bold

Formatted: Font: 11 pt, Not Bold

Formatted: Font: 11 pt, Not Bold

Formatted: Font: 11 pt, Not Bold

Formatted: Font: 11 pt, Not Bold

Formatted: Font: 11 pt, Not Bold



**Figure 11 – multi-storey glulam with top boards building**

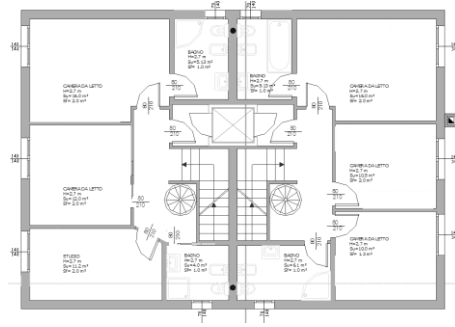

**Figure 12 – standard floor map**

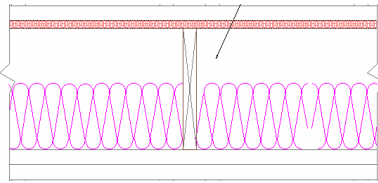

**Figure 13 – floor assembly scheme and closures detail. Materials and thickness from the top: 2.2 mm of wooden chipboard, 200 mm of wooden beams, 100 mm of rock wool density 55 kg/m<sup>3</sup>.**



**Figure 14 – high sound insulation foam insertion**

## 2.5 Glulam beams with top boards results

As for Cross Laminated Timber structures, the same considerations could be applied here: different bare floors results are very similar due to industrial production, so here for brevity only average final values are worthy of being presented. In [Figure 15](#) the bare floor impact noise is reported both without and with insulating foam inserted inside the air gap between panels. It is evident how the insertion makes the panels work together, thus providing more energy (more excited area) at low frequencies. Nevertheless, the airborne sound insulation performance improved. The single number value  $R'_w$  increased by 12 dB.

**Formatted:** Font: 11 pt, Not Bold

**Formatted:** Font: 11 pt, Not Bold



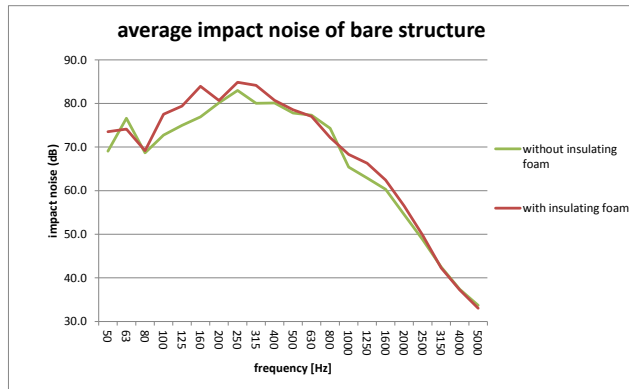

Figure 15 – bare floor impact noise

After these steps, a first floating floor was posed by the authors using the following layers (Figure 16):

- i. recycled cotton waste resilient layer ( $s' = 32 \text{ MN/m}^3$ ,  $d = 8 \text{ mm}$ )
- ii. marble powder in honeycomb paper panels ( $m' = 45 \text{ kg/m}^2$ )

Then a second floating floor was laid upon the first one using the following coatings (Figure 17):

- iii. recycled cotton waste resilient layer ( $s' = 32 \text{ MN/m}^3$ ,  $d = 8 \text{ mm}$ )
- iv. two gypsum fibreboards ( $m' = 35 \text{ kg/m}^2$ )

Impact noise tests using an ISO tapping machine were carried out (Figure 18) and the influence of these sound reduction solutions is reported in Figure 19.

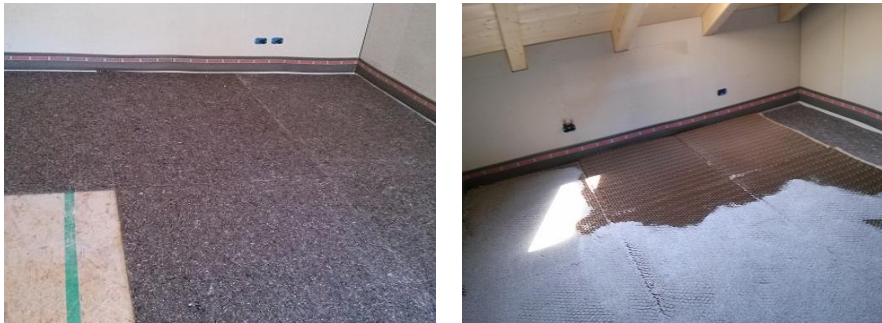

Figure 16 – first floating floor realization



Formatted: Font: 11 pt, Not Bold

Formatted: Font: 11 pt, Not Bold

Formatted: Font: 11 pt, Not Bold

Formatted: Font: 11 pt, Not Bold

Formatted: Font: 11 pt, Not Bold

Formatted: Font: 11 pt, Not Bold

Formatted: Font: 11 pt, Not Bold

Formatted: Font: 11 pt, Not Bold

**Figure 17 – second floating floor realization**

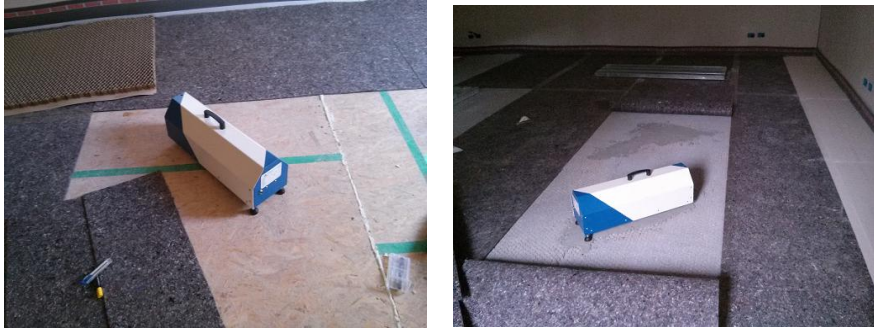

**Figure 18 –location of tapping machine during tests: bare floor (left) and first floating floor (right)**

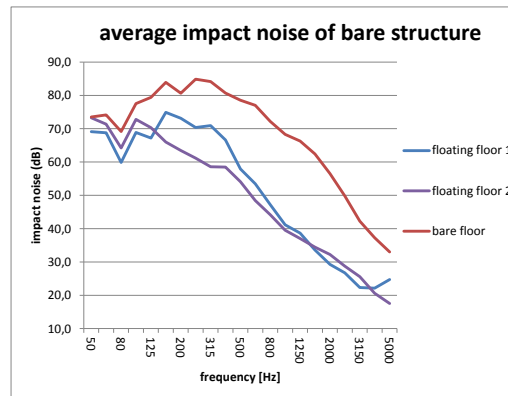

**Figure 19 – floating floors influence**

Afterwards, a screwed ceiling was posed. This setup implies an additional plasterboard (1 cm thickness) underneath the timber floor. It was screwed on wooden beam (50 mm thickness) with a resulting air gap of 50 mm. In [Figure 20](#) the influence of the screwed ceiling is reported.

The worsening caused by the presence of this element is evident. At around 100 Hz its resonance frequency increases the impact noise, according to equation (4):

$$(4) \quad f_0 = 60/\sqrt{(m'/d)} \quad [\text{Hz}]$$

where  $m'$  is the mass per unit area [ $\text{kg}/\text{m}^2$ ] of the plasterboard ( $6,5 \text{ kg}/\text{m}^2$ ) and  $d$  is the distance (0.05 m) from the floor structure [m].

In order to reduce this effect, the air gap was filled with mineral wool. This operation slightly lowered the middle frequencies but did not change the resonance influence on the impact noise.

Formatted: Font: 11 pt, Not Bold

Formatted: Font: 11 pt, Not Bold

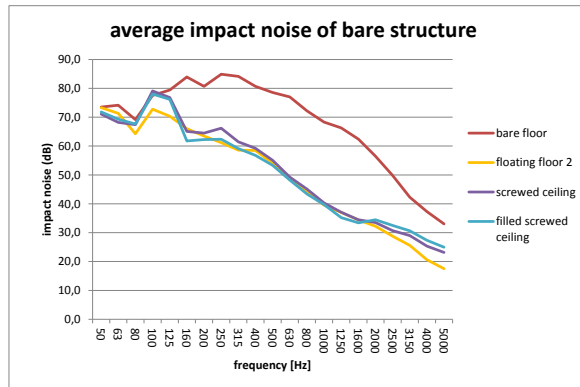

Figure 20 – screwed ceiling effect

## 2.6 Discussion of results

For the Cross Laminated Timber technology the average frequency trend was calculated using the 16 impact noise measurements reported in [Figure 10](#). At a latter time the linear regression was calculated in order to obtain a possible predicting equation of the impact noise of bare floor. The frequency trends are reported in [Figure 21](#).

The mean value of the frequency spectrum trend can be represented with the following equations:

- (5)  $L_{n,eq,avg} = -0.15 (f) + 77.7$  (dB) for  $50 < f < 80$  Hz
- (6)  $L_{n,eq,avg} = 7.26 \log (f) + 35.6$  (dB) for  $100 < f < 630$  Hz
- (7)  $L_{n,eq,avg} = -0.006 (f) + 84.4$  (dB) for  $800 < f < 5000$  Hz

The calculated linear regression coefficient is  $R^2=0.99$  for equation (5),  $R^2=0.89$  for equation (6) and  $R^2=0.97$  for equation (7)

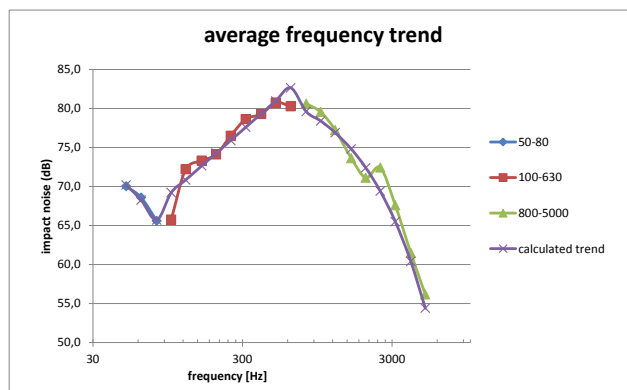

Formatted: Font: 11 pt, Not Bold

Formatted: Font: 11 pt, Not Bold

Formatted: Font: 11 pt, Not Bold

Formatted: Font: 11 pt, Not Bold

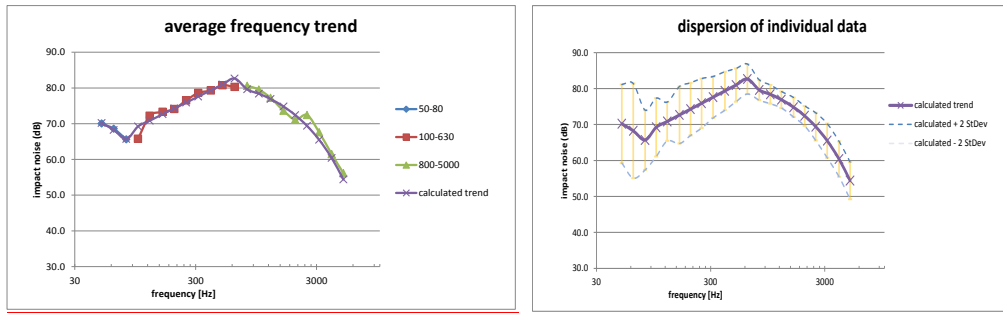

**Figure 21 – Average frequency trends for impact noise and calculated linear regression and dispersion of individual data. 95% of the measured values are situated inside the yellow lined zone**

A comparison can be carried out using the values provided by the literature for similar structures. In [Figure 22](#) ~~Figure 22~~ the comparison between Cross Laminated Timber and timber concrete structures is reported. It is worth to note that the influence of the concrete slab starts from middle-high frequencies according to [14].

In [Figure 23](#) ~~Figure 23~~ the comparison between different Cross Laminated Timber floors thickness is reported. It is evident that the influence of this parameter changes the frequency trend, altering the behaviour at almost every frequency. Nevertheless the comparison between laboratory results (Germany and Canada) shows how trends are almost the same and the difference is only depending on the thickness. This demonstrate once more the trustworthiness of measured data.

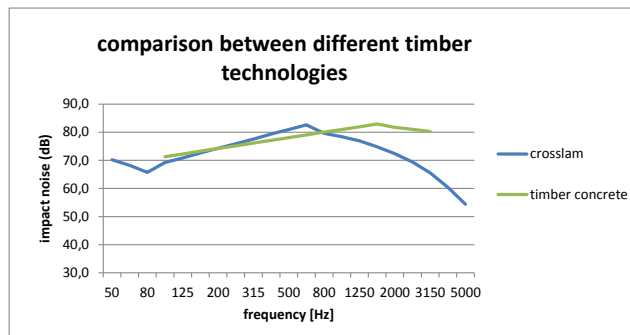

**Figure 22 – comparison between Cross Laminated Timber (equation (4), (5) and (6)) and timber concrete [33] floors**

Formatted Table

Formatted: Font: 11 pt, Not Bold

Formatted: Font: 11 pt, Not Bold

Formatted: Font: 11 pt, Not Bold

Formatted: Font: 11 pt, Not Bold

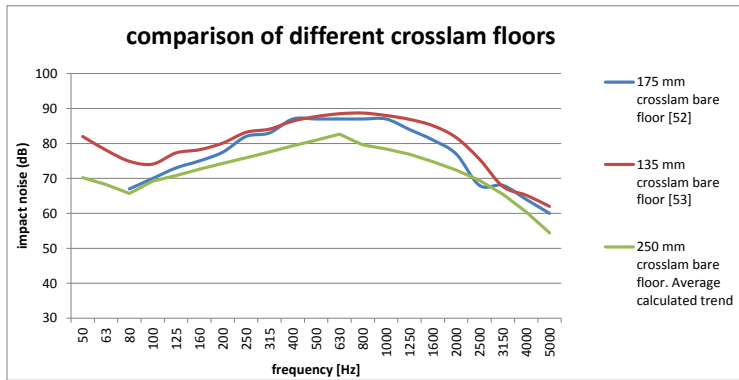

**Figure 23 – comparison between different thickness of Cross Laminated Timber floors: average calculated trend (equation (4), (5) and (6)), and literature data [52], [53]**

From the single index point of view, in [Table 3](#), the normalized impact sound pressure index values, calculated according to ISO 12354-2 [9] are described. The first line reports the single index value calculated using ISO 717-2 methods [51]; for the 250 mm bare floor the frequency trend provided by equations (5), (6) and (7) was used for calculation. No flanking transmissions were taken into account since the  $L_{n,w}$  parameter was analysed (laboratory tests).

It is evident that the standard method does not provide reliable results. In fact it is suggested for homogeneous bare concrete floor with a mass per unit area  $100 \text{ kg/m}^2 < m' < 600 \text{ kg/m}^2$ . The provided results differ from the measured values up to 10.5 dB. Nevertheless, since this is the only available method, a correction is proposed according to equation (8):

$$(8) \quad L_{n,w,eq,corrected} = 134.5 - 25 \cdot \log(m') \text{ (dB)}$$

where  $m'$  is the mass per unit area [ $\text{kg/m}^2$ ] of the CLT floor. Using this method the measured and predicted results agree very well. These results are in a good agreement with literature one [50].

**Table 3 – normalized impact sound pressure index values for Cross Laminated Timber bare floors**

	135 mm bare floor [53]	175 mm bare floor [52]	250 mm bare floor eq. (5),(6),(7)
Measured $L_{n,w}$	88	85	80
$L_{n,w}$ according to ISO 12354-2 model	98.5	94.6	89.2
$L_{n,w}$ according to ISO 12354-2 modified model	87.7	84.9	81.0

Formatted: Font: 11 pt

Formatted: Font: 11 pt

For glulam beams with top boards, in [Table 4](#) the comparison between ISO 12354-2 normalized impact sound pressure index models (see equation (9)) and measured values is shown. Presented results were calculated using the average of all tests.

$$(9) \quad \Delta L_{nw, \text{single number}} = 30 \cdot \log(500/f_0) + 3 \text{ (dB)}$$

where  $f_0$  is the resonance frequency of the floating floor.

It is clear that the relation is not applicable with timber structures since the bare floors are not of infinite mass in comparison with the floating layers. The difference in mass is reduced ( $m'_{\text{bare floor}}=130 \text{ kg/m}^2$  whether  $m'_{\text{overall floating floor}}=80 \text{ kg/m}^2$ ) in comparison with a concrete bare floor ( $m'_{\text{concrete}}=600 \text{ kg/m}^2$ ) or beam and pot ( $m'_{\text{beam and pot}}=340 \text{ kg/m}^2$ ). The focus is the impact of the traditional floating floor; since the flanking transmission value are constant from bare floor to covered floor the measured final values are influenced only by the additional floating layer.

**Table 4 – floating floors normalized impact sound pressure index prediction for glulam bare floor.**  
Single number identification

TIMBER	Mass per unit area [kg/m <sup>2</sup> ]	Measured Normalized Impact sound pressure index $L'_{n,w}$ (dB)	Predicted Normalized Impact sound pressure index $L'_{n,w}$ (dB)	Difference (dB)
Bare floor	130	76	--	--
Floating floor 1	45	64	54	10
Floating floor 1+2	80	58	46	12

In [Table 5](#) a comparison of the sound reduction index of an ideal floating floor, used as example, on different structures is presented, using the frequency of Cremer's relation [10] reported in equation (9).

The floating floor is composed of a high density coating (90 kg/m<sup>2</sup>, 50 mm thickness) and a resilient layer ( $s' = 16 \text{ MN/m}^3$ ).

Formatted: Font: 11 pt

Formatted: Font: 11 pt

Formatted: Font: 11 pt

Formatted: Font: 11 pt

Here, it is evident how the same impact sound reduction solution provides very diverse performance, depending on the type of bare horizontal partition. This result depends on the different distribution of the exciting energy coming from the ISO tapping machine [54] - [58] and on the specific limit of floating floor technology: low frequency reduction.

**Table 5 – floating floor effect on same thickness different bare floor technologies using frequency Cremer’s relation. Frequency trend calculation**

	Mass per unit area [kg/m <sup>2</sup> ]	Measured Normalized Impact sound pressure index of bare floor (dB)	Predicted Normalized Impact sound pressure index reduction of floating floor (dB)
Glulam	130	76	14
Concrete [59]	600	81	33
Beam and pot [33]	340	87	41

In [Figure 24](#) ~~Figure 24~~ ~~Figure 24~~ the impact noise of different bare floor technologies is presented.

Traditional beam and pot and timber concrete floors tested previously by the authors [33] and laboratory test of concrete one [59] provide an interesting comparison. As a matter of fact, timber based structures provide more low frequency energy (up to 20 dB) than the concrete based ones, involving a lower floating floor influence on them.

Another feature concerns the high frequency trend. Timber concrete, concrete and beam and pot structures provides energy at high frequency. This is highlighted also in hybrid cross laminated timber bare floors (CLT with an additional concrete layer) [60],[61]. The high frequency sound pressure level is caused by the impact of the ISO tapping machine on concrete slab rising the trend and the final single index value.

The mineral wool effect on impact sound reduction is evident in glulam beams with top board partition, especially at high frequency according to [62]. Nevertheless, this range is the one in where the floating floor acts best. Once more its influence cannot be highlighted since this type of structures does not provide an ideal condition for the use of this sound reduction technology.

**Formatted:** Font: 11 pt, Not Bold

**Formatted:** Font: 11 pt, Not Bold

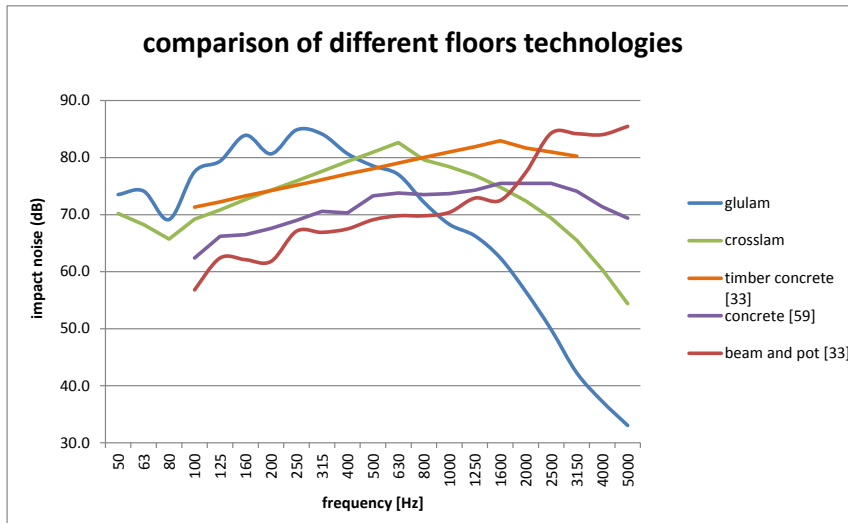

**Figure 24 – comparison of different bare floor technologies of impact noise: glulam, Cross Laminated Timber, timber concrete [33], concrete [59], beam and pot [33]**

Finally, for the extension of the proposed formula to all type of floors, the flanking transmissions have to be considered and evaluated.

In the CLT case study, the transmission paths were identified both in CLT and GLT walls (lighter than the CLT tested floors), whether in the other one only timber frame structures were present.

Connection methods of cross laminated timber element affect the radiation efficiency of the bare construction. This is basically due to the fact that in laboratory all the mounting tolerances are very controlled. But the in situ situations will be surely different since there is no control in mounting tolerances and very different screws or angle brackets could be used as evidenced by Barbaresi et al. [49]. Nevertheless, the same authors conclude that if all the differences were due to the mounting tolerances, one could draw the conclusion that in situ realizations will provide a more uniform behaviour among the panels due to the greater number of constraints [ibid.]. In other words in situ realization are less affected by fastening systems, since they are more rigid than laboratory ones.

This fact is now confirmed since from the mass ration point of view, flanking walls were various: CLT or GLT ones. Referring to Table 2, it did not seem to affect the final single number results. Hence a preliminary conclusion could be drawn: if the flanking walls are lighter than floors, then the influence of CLT and GLT flanking path difference could be very low.

As a matter of fact prISO12354-2 [63] does not include mixed structures evaluations since in section concerning the GLT technology the crosslam one is explicitly excluded. The topic of flanking transmissions in CLT-CLT constructions is implemented within pr ISO 12354-1 where a possible formulation is provided according to literature [64]. Here, no influence of the screwing or



bracketing systems is described or requested, because it is almost impossible for designers to forecast how many fastening system will be used during construction and of which type, diameter or length.

Therefore, the validity of the proposed formula is limited by the assumption of similar connection conditions between the structures. To extend the results to other types of connections between nude structures also this aspect have to be considered and further investigation had to be performed.

## **2.7 Conclusions**

In situ measurements on full-scale timber constructions were used to investigate the frequency behaviour of impact noise of bare floors and the influence of floating floor technology on timber horizontal partitions.

Two main typologies were analysed: Cross Laminated Timber and Glulam with screwed top boards. Results clearly indicate how the industrial production method of timber structures provides a very good repeatability and reproducibility of the measures on both technologies since all panels are manufactured, transported and assembled in the same way.

A new frequency model for impact noise of Cross Laminated Timber bare floors is proposed and validated using literature, laboratory tests and *in situ* measurements, showing a bell trend with the peak centred on middle frequencies (315 Hz – 1250 Hz).

Comparison between timber and traditional technologies is provided, showing how wooden structures irradiate up to 20 dB more energy in the low frequency range while concrete hybrid structures provide high frequency energy due to the influence of massive slab. A correction of the ISO 12354-2 model for single number prediction is proposed, related to Cross Laminated Timber structures.

Furthermore, the influence of floating floor is analysed on a GLT bear floors and a step-by-step measurement was performed after the realization of two different floating floors. The results highlight the minor impact of this technology on lightweight structures compared to the heavyweight traditional ones because of the big bare floors difference of mass per unit area.

Finally, the influence of mineral wool and screwed ceiling shows how the former acts on high frequencies and influences the effect of the floating floor, while the latter worsens the final impact noise level because of its resonance frequency. The suspended ceiling act as the best way to reduce impact noise while the fastened ceiling act as an additional radiant layer aggravating the noise level at its resonance frequency.

### **Acknowledgments**

This research was funded with a Ph.D scholarship by MIUR (Italian Ministry of University) which is gratefully acknowledged.

### **Author Contributions**

All authors contributed equally to the conception of this study

## Appendix A

### Abbreviation list

$L_n$	Resulting impact noise
$L_{n,0}$	Impact noise of the bare floor
$\Delta L$	Impact sound pressure level reduction
$f$	frequency
$f_0$	resonance frequency
$s'$	apparent dynamic stiffness per unit area
$m'$	mass per unit area
$L'_{n,T}$	Impact noise in situ measured or calculated levels
$C_{1,50-2500}$	Correction coefficient for 50 Hz – 2500 Hz frequency range
$R'_w$	Airborne sound insulation in situ measured value
$d$	distance
$L_{n,eq,avg}$	Impact noise level of regression calculation
$R$	calculated linear regression coefficient

## References

- [1] [Á. Lakatos Á.](#), Comparison of the Thermal Properties of Different Insulating Materials, [Advanced Materials Mat. Research Res.](#) 2014, 899, 381-386
- [2] [Á. Lakatos Á.](#), Investigation of the moisture induced degradation of the thermal properties of aerogel blankets: Measurements, calculations, simulations, [Energy and Buildings Build.](#), Volume 139, 15 March 2017, Pages 506-516
- [3] L. De Geetere, B. Ingelaere, A new building acoustical concept for lightweight timber frame constructions, [Proceedings Proc. of Internoise 2014](#), Melbourne
- [4] F. Ljunggren, C. Simmons, K. Hagberg, Correlation between sound insulation and occupants' perception - Proposal of alternative single number rating of impact sound, [Applied Acoustics Acoust.](#), 85, (2014) pp. 57-68
- [5] F. Ljunggren, C. Simmons, K. Hagberg, Findings from AkuLite project: Correlation between measured vibro-acoustic parameters and subjective perception in lightweight buildings, [Proceedings of Internoise](#), 2013, Innsbruck
- [6] W-H Lee, K-W Kim, S-H Lim, Improvement of floor impact sound on modular housing for sustainable building. [Renewable & Sustainable Sust. Energy-Reviews](#) 2014; 29:263–75. doi:10.1016/j.rser.2013.08.054.
- [7] I.L. Vérz, Impact Noise Isolation of Composite Floors, [J. Acoust. Soc. Am.](#) 1971; 50:1043–50. doi:10.1121/1.1912726.
- [8] E. Gerretsen, Predicting the sound reduction of building elements from material data,

Building-Build. Acoustics-Acoust. 1999; 6:225–34. doi:10.1260/1351010991501428.

- [9] ISO 12354-2: “Building acoustics. Estimation of acoustic performance in buildings from the performance of elements. Impact sound insulation between rooms”
- [10] L. Cremer, Theorie der scaldämmung wände dei schrägem eifall, Akust. Z, 7 1942, 81-104
- [11] R. Di Monte , M. Caniato , I. Boscarato, J. Kaspar, O. Sbaizero, Green cork-based innovative resilient and insulating materials: Acoustic, thermal and mechanical characterization, Proc. Mtgs. Acoust.Proceedings of Meetings on Acoustics, Volume 19, 2013, Article number 040096, 6p
- [12] F. Bettarello, M. Caniato, R. Di Monte, J. Kaspar, O. Sbaizero, Preliminary Acoustic tests on resilient materials: Comparison between common layers and nanostructured layers, 20th International Congress on Acoustics 2010, ICA 2010 - Incorporating Proceedings of the 2010 Annual Conference of the Australian Acoustical Society, Volume 2, 2010, Pages 1096-1101
- [13] M.A. Stewart, R.K. Mackenzie, A comparison of the predicted dynamic stiffness of resilient layers with calculated values obtained from the measured acceleration response, Building Buil. Acoustics-Acoust. 2000; 7:297–313. doi:10.1260/1351010001501679
- [14] B. Ingelaere, D. Wuyts, Impact sound measurements on wooden floors. Project AH+, part 6, Proceedings Proc. of Internoise, 2013, Innsbruck
- [15] A. Schiavi, C. Guglielmone, P. Miglietta, Effect and importance of static-load on airflow resistivity determination and its consequences on dynamic stiffness. Applied Acoustics-Acoust. 2011; 72:705–10. doi:10.1016/j.apacoust.2011.03.009
- [16] A. Hiramitsu, Effect of change in impact force on heavy-weight impact sound and impact characteristic of heavy/soft impact sources, Noise Control-Contr. Engineering-Eng. JournalJ., Volume 59, Issue 5, September 2011, Pages 497-504
- [17] J. Ryu, H. Sato, K. Kurakata, A. Hiramitsu, M. Tanaka, T. Hirota, Relation between annoyance and single-number quantities for rating heavy-weight floor impact sound insulation in wooden houses, Journal-J. of Acoustic-Acoust. society soc.of AmericaAm., 129 (5), May 2011
- [18] J. D. Quirt, T. R. Nightingale, F. King, Guide for Sound Insulation in Wood Frame Construction, NRC Publications Archive (NPARC) Archives des publications du CNRC (NPARC), available at <http://nparc.cisti-icist.nrc-cnrc.gc.ca/npsi/ctrl?lang=en> accessed on 22<sup>nd</sup> February 2016
- [19] M. Caniato, F. Bettarello, L. Marsich, A. Ferluga, O. Sbaizero, C. Schmid, Time-depending performance of resilient layers under floating floors, Construction and Building-Build. Materials Mater. 102, 226-232
- [20] J. Medved, B. Ingeleare, L. De Geetere, Impact sound insulation concept for lightweight timber floor, Advanced-Advan. Materials-Mater. ResearchRes., vol 855, pp 245-251, 2014
- [21] F. Ljunggren, A. Ågren, Elastic layers to reduce sound transmission in lightweight buildings, Building-Build. AcousticsAcoust., Volume 20 n.1 (2013) pp 25-42
- [22] M. Caniato, F. Bettarello, O. Sbaizero, C. Schmid, Recycled materials for noise reduction in floating floors, 22nd International Congress on Sound and Vibration, ICSV 2015

- [23] Å. Bolmsvik, A. Brandt, Damping assessment of light wooden assembly with and without damping material, *Engineering Eng. Structures*, 49 (2013) 434-447
- [24] A. Hiramatsu, Y. Hasemi, T. Kaku, Floor impact sound insulation of timber three-story school building for final full scale fire test, *Proceedings Proc. of Internoise*, 2014, Melbourne
- [24][25] [COST Action FP0702. Net-Acoustics for Timber based lightweight buildings and elements e-book, available at http://extranet.cstb.fr/sites/cost/ebook/Forms/AllItems.aspx/, accessed on 1<sup>st</sup> of may 2017](http://extranet.cstb.fr/sites/cost/ebook/Forms/AllItems.aspx/)
- [25] ~~COST action FP0702, "Acoustic Design of Lightweight Timber Frame Construction"~~ report
- [26] J. Negreira, D. Bard, Modelling of the tapping machine for finite element prediction tools – Preliminary parametric studies, *Proceedings Proc. of ICA*, 2016, Buenos Aires
- [27] J.-L. Kouyoumji, G. Borello, H. Ferk, Reverse sea to predict flanking transmission in timber framed constructions, *Proceedings Proc. of ICA*, 2016, Buenos Aires
- [28] D. Bard, K. Hagberg, T. Augustsson, Modelling various floor and wall assemblies and comparisons to measured values, *Proceedings Proc. of ICA*, 2016, Buenos Aires
- [29] C. Hopkins, M. Filippopolitis, N. Ferreira, Ra. Voltl, U. Schanda, J. Mahn, L. Krajci, Vibroacoustic finite element modelling of the low-frequency performance of a solid timber floor formed from dowel- connected joists, *Proceedings Proc. of Internoise*, 2016, Hamburg
- [30] F. Schöpfer, C. Hopkins, A. Mayr, U. Schanda, Modelling structure-borne sound transmission across a timber-frame wall using SEA, *Proceedings of Internoise*, 2016, Hamburg
- [31] H-M. Tröbs, S. Schoenwald, A. Zemp, Energy distribution and sound radiation caused by the segmentation of a glulam timber floor, *Proceedings of Internoise*, 2016, Hamburg
- [32] <http://www.lignumdata.ch> accessed on 4th of april 2017
- [33] F. Bettarello, P. Fausti, V. Baccan, M. Caniato, Impact sound pressure level performances of basic beam floor structures. *Building—Build. Acoustics—Acoust.* 2010; 17:305–16. doi:10.1260/1351-010X.17.4.305
- [34] K. Jarnerö, A. Brandt, A. Olsson, Vibration properties of timber floor assessed in laboratory and during construction, *Engineering Eng. Structures*, 82 (2015) 44-54
- [35] L. Cremer, M. Heckl, B.A.T. Petersson, Structure-borne sound structural vibrations and sound radiation at audio frequencies, Berlin; New York: Springer; 2005
- [36] Späh M, Hagberg K, Bartolomé O, Weber L, Leistner P, Liebl A, Subjective and objective evaluation of impact noise sources in wooden buildings, *Build Acoust*, Vol. 20, n. 3 2013 pp. 193-214
- [37] ~~J. Ryu-J, H. Sato-H, K. Kurakata-K, A. Hiramatsu-A, M. Tanaka-M, T. Hirota-T~~, Relation between annoyance and single-number quantities for rating heavy-weight floor impact sound insulation in wooden houses, *J. Acoust. Soc. Am.* , 129 (5), May 2011
- [38] N. Granzotto, F. Bettarello, A. Ferluga, L. Marsich, C. Schmid, P. Fausti, M. Caniato, Energy and acoustic performances of windows and their correlation, *Ener. Build.*, Volume 136,

2017, Pages 189–198

- [39] Directive 2002/91/EC of the European Parliament and of the Council of 16 December 2002 on the energy performance of buildings
- [40] M. Caniato, F. Bettarello, C. Schmid, P. Fausti, Assessment criterion for indoor noise disturbance in the presence of low frequency sources, ~~Applied Appl. Acoustics Acoust.~~ 113 (2016) 22–33
- [41] M. Caniato, F. Bettarello, P. Fausti, L. Marsich, A. Ferluga, C. Schmid, Low frequency noise and disturbance assessment methods: a brief literature overview and a new proposal, 22nd International Congress on Acoustics ICA 2016, Buenos Aires
- [42] H.G. Leventhall, Low Frequency Noise. What we know, what we do not know, and what we could like to know, ~~Journal J. of Low Frequency Freq. Noise Vibration Vib. and Active Control Cont.~~, Vol. 28 No. 2 2009
- [43] H.G. Leventhall, S. Benton and D. Robertson, Coping Strategies for Low Frequency Noise, ~~J. of Low Freq. Noise Vib. Active Cont. Journal of Low Frequency Noise Vibration and Active Control~~, Vol. 27 No. 1 2008
- [44] T. Watanabe and H. Møller, Low frequency hearing thresholds in pressure field and free field. ~~J. of Low Freq. Noise Vib. Active Cont. Journal of Low Frequency Noise Vibration and Active Control~~, Vol. 9, No. 3, 1990, p. 106-115
- [45] M. Caniato, F. Bettarello, F. Patrizio, L. Marsich, A. Ferluga, C. Schmid, Low frequency noise and disturbance assessment methods: A brief literature overview and a new proposal, ~~Proc. Mtgs. Acoust., Proceedings of Meetings on Acoustics~~ 28, 032001 (2016); doi: <http://dx.doi.org/10.1121/2.0000341>
- [46] ~~G.-Q. Dii, Guo Qing, Q.-L. Lin, Qi Li, H.-H. Zhao, Hang Hai, Y.-J. Guo, Yan Jie~~, Proposed Revision to Emission Limits of Structure-Borne Noise from Fixture Transmitted into Room: An Investigation of People's Annoyance, Acta Acustica united with Acustica, Volume 97, Number 6, November/December 2011, pp. 1034- 1040\_(7)
- [47] ISO 16283-2:2015, Acoustics -- Field measurement of sound insulation in buildings and of building elements -- Part 2: Impact sound insulation
- [47][48] ~~C. Hopkins, On the efficacy of spatial sampling using manual scanning paths to determine the spatial average sound pressure level in rooms, J. Acoust. Soc. Am., 2011, 129(5), pp. 3027-3034~~
- [48] ~~ISO 10052:2004, Acoustics -- Field measurements of airborne and impact sound insulation and of service equipment sound -- Survey method~~
- [49] ~~L. Barbaresi, F. Morandi, M. Garai, A. Speranza, Experimental measurements of flanking transmission in CLT structures, Proc. Mtgs. Acoust. 28, 015015 (2016). doi: <http://dx.doi.org/10.1121/2.0000433>, Speranza, A., Barbaresi, L., Morandi, F., Experimental analysis of flanking transmission of different connection systems for CLT panels, WCTE 2016—World Conference on Timber Engineering, Vienna~~

Formatted: Indent: Left: -0.02 cm, Hanging: 0.02 cm

Formatted: Indent: Left: 0 cm, First line: 0 cm

[50] [A Di Bella, N. Granzotto, L. Barbaresi, Analysis of acoustic behavior of bare CLT floors for the evaluation of impact sound insulation improvement, Proc. Mtgs. Acoust. 28, 015016 \(2016\), doi: <http://dx.doi.org/10.1121/2.0000420>](#)~~A Di Bella, N. Granzotto, L. Barbaresi, Analysis of acoustical behavior of bare cross laminated timber floors for the evaluation of the improvement of impact sound insulation, Proc. ICA 2016, Buenos Aires, 2016~~

[51] ISO 717-2:2013 Acoustics -- Rating of sound insulation in buildings and of building elements -- Part 2: Impact sound insulation

[52] W. Byrick, Laboratory data examining impact and airborne sound attenuation in cross-laminated timber panel construction, ~~Proceedings of~~ Internoise, 2015, San Francisco

[53] IFT Rosenheim laboratory test report, n.L07, 12.11.2013

[54] C. Johansson, Low-frequency impact sound insulation of a light weight wooden joist floor, Appl. Acoust. 44 (1995) 133–147

[55] S. Schoenwald, B. Zeitler, T.R.T. Nightingale, Prediction of the blocked force at impact of Japanese rubber ball source, Acta Acustica united with Acustica Volume 97, Issue 4, July 2011, Pages 590-598

[56] ~~T. Nakao, Tetsuya, C. Tanaka, Chiaki, A. Takahashi, Akira~~, Source wave analysis of impact force on wood based panel floor, Zairyo/~~Journal J. of the Society Soc. of Materials Mater. ScienceSc.~~, Japan Volume 37, Issue 416, May 1988, Pages 565-570

[57] A. Hiramitsu, Effect of change in impact force on heavy-weight impact sound and impact characteristic of heavy/soft impact sources, Noise ~~Control Contr. Engineering Eng. Journal~~, Volume 59, Issue 5, September 2011, Pages 497-504

[58] J. Brunskog, P. Hammer, The interaction between the ISO tapping machine and lightweight Floors, Acta Acustica united with Acustica 89(2):296-308 March 2003

[59] LAB FT laboratory test report, n. 15-850-001, 20.03.2015

[60] M. Golden, W. Byrick, Laboratory Data Examining Impact and Airborne Sound Attenuation in Cross - Laminated Timber Panel Construction - Part 2, ~~Proceedings Proc. of~~ Internoise, 2016, Hamburg

[61] A. Homb, Hybrid cross-laminated timber floors. Comparison of measurements and calculations, ~~Proceedings Proc. of~~ ICA, 2016, Buenos Aires

[62] J. Brunskog, P. Hammer, Prediction Model for the Impact Sound Level of Lightweight Floors Acta Acustica united with Acustica 89(2):309-322 March 2003

[63] [ISO/FDIS 12354-2, Building acoustics — Estimation of acoustic performance of buildings from the performance of elements — Part 2: Impact sound insulation between rooms](#)

[62][64] [C. Guigou-Carter, M. Villot, Junction characteristics for predicting acoustic performances of lightweight wood-based buildings, Proc. Internoise San Francisco, 2015](#)

## Impact noise of timber floors in sustainable buildings

Marco Caniato<sup>1,3,\*</sup>, Federica Bettarello<sup>2</sup>, Patrizio Fausti<sup>3</sup>, Alessio Ferluga<sup>1</sup>, Lucia Marsich<sup>1</sup>, Chiara Schmid<sup>1</sup>

<sup>1</sup> Engineering and Architecture Department, University of Trieste, via Valerio 6/a, 34127 Trieste, Italy

<sup>2</sup> AcusticaMente Engineering consulting, via Garibaldi 13/b, 31015 Conegliano (TV), Italy

<sup>3</sup> Department of Engineering, University of Ferrara, via Saragat 1, Ferrara, Italy

\* corresponding author: [mcaniato@units.it](mailto:mcaniato@units.it); +39347316728; FAX +39 040 558 3836

### Abstract

Timber buildings represent a robust alternative to traditional heavyweight constructions. They allow CO<sub>2</sub> storage, high structure and performance reproducibility, fast assembly and final certification of every panel.

Nowadays, acoustic insulation is one of the most requested performances on the part of inhabitants, but not always fulfilled. Since these kind of edifices are relatively new in the market, there are very few studies on acoustic properties, regarding on impact sound performances. In this paper, an in-depth analysis of impact noise on bare timber floors is presented, focusing on how impact sound reduction cannot be as efficient as in heavyweight constructions. Two new equations are proposed, modelling the impact sound pressure level of common bare timber structures and the influence of traditional floating floor systems is analysed.

Keywords: Sustainable timber buildings; acoustic; impact sound insulation; precast energy saving panels

### 1. Introduction

Lightweight precast timber buildings are present worldwide and their market trend is growing, since the related thermal insulation performances provide very good final results. They allow CO<sub>2</sub> storage, since wood is widely used, as it is a renewable and environmentally friendly raw material and commonly a very good thermal insulation is provided thanks to traditional [1] and new materials [2] use. Generally, these constructions are built within industry plants where costs are minimised beforehand and where it is ensured that as little waste as possible is produced, according to Kyoto protocol purposes [3].

Furthermore, prefabrication often means high repeatability since specialised workmanship is used, including CAD-CAM technologies, permitting new and complex architectural shapes, concepts and tendencies. In addition, the final product needs CE certifications, so as to ensure quality.

Nevertheless, acoustic performances are not always at the top range. For example, impact noise in timber constructions is the most common cause of complaint on the part of inhabitants [4], because in this kind of lightweight buildings the usual impact reduction methods would not properly work.

In fact, in traditional heavyweight buildings high density solutions are often used in order to reduce the impact sound pressure level [5]-[8]; the standard ISO 12354-2 [9] includes the analytical model as reported in equation (1):

$$(1) \quad L_n = L_{n,0} - \Delta L \quad (\text{dB})$$

where  $L_n$  is the resulting impact noise (dB),  $L_{n,0}$  is the impact noise of the bare floor (dB),  $\Delta L$  is the impact sound pressure level reduction (dB).

It is evident that the bare floor acts as starting point and so the type of partition is the primary source.

The floating floor is one possible solution for the reduction of the impact sound pressure level using the mass-spring-mass effect based on Cremer's theory [10]. This method is widely used and successfully applied from the design process to the realization of the building.

The floating floor is nowadays one of the best and safest solution to reduce impact noise in heavyweight constructions. It includes a heavy bare floor, a resilient layer and a heavy upper slab; the analytical method is reported in equations (2) and (3).

$$(2) \quad \Delta L = 30 \log(f/f_0) \quad (\text{dB})$$

where  $\Delta L$  is the impact sound pressure level reduction (dB),  $f$  is the frequency [Hz] and  $f_0$  is the resonance frequency [Hz] of the spring-mass system expressed by

$$(3) \quad f_0 = (1/2\pi)\sqrt{(s'/m')} \quad [\text{Hz}]$$

where  $s'$  is the apparent dynamic stiffness per unit area [ $\text{MN}/\text{m}^3$ ] and  $m'$  is the mass per unit area of the massive slab [ $\text{kg}/\text{m}^2$ ].

As a matter of fact, the floating floor depends on the density of the upper slab and on the dynamic stiffness value of the resilient material [11] - [13] as explicated in equation (2) and (3). So what may change the final results is the bare floor impact noise trend. Furthermore, the reduction provided by the floating floor is not constant in the frequency domain [14]-[17].

In recent years many researchers have tried to deal with these new topics, stating that in particular the lightweight timber floors do not behave as the heavyweight ones [18]-[24]. Many project were developed; COST action FP90702 [25] reports that the wooden structures present a better insulation in middle and high frequency range than the heavy weight ones. As a consequence, the low frequency influence has to be further investigated.



Silent Timber Building project developed many tools and databases focusing on SEA calculation and prediction (as an example see [26] - [28]); this topic was also studied in independent researches (as an example see [29] - [31]) demonstrating the high interest on this type of constructions.

Many measurements were performed in years on different complete structures and an on line database was created [32]. Nevertheless, no bare structures is indexed in it.

All these studied reports similar initial or general results: timber structures are various and even if they are very repeatable, there are several differences between one producer to another.

Furthermore, applying the same prediction methods or analysis used for heavyweight constructions could yield rather approximate results. Recent studies [33]-[34] show how different bare floors (heavyweight concrete slab, beams and pots and lightweight timber concrete ones) present dissimilar impact sound pressure levels and consequently floating floor sound reduction could not ensure same results [35].

Nowadays the progress of modern constructions more and more includes lightweight buildings. At present 6 edifices out of 100 are erected using timber constructions in Europe [36]; in Japan the enforcement of the Act for Promotion of use of wood in Public Buildings pushed this technology to grow rapidly [37]. They provide many advantages like speed of assembly, industrial quality, reduction of workmanship errors, fast realization of difficult shapes, high integration of service equipment and windows [38].

The presence of timber buildings has grown in Europe since recent directive of the European Parliament [39] encourages the realization of new high performance buildings.

Different technologies are available but two types are most used: glulam beams with top boards (GLT) or cross-laminated timber panels (CLT). For both of them no standard or international literature provide a theoretical or empirical  $L_{n0}$  or frequency trend values in order to predict bare floors impact noise. This is the primary input data since the designing process is based on ISO 12354-2 [9] and Cremer's theory [10].

Especially at low frequency range (the more disturbing and annoying one [40]-[46]), this excitation is difficult to model because of two causes:

- i. the typologies of glulam beams with top boards are various; this fact decelerates possible researches and makes them very difficult;
- ii. the traditional models do not work with lightweight structures.

In this work, an in-depth study of the impact noise performance of bare timber floors is carried out, focusing on the results of in situ measurements. The aim of this paper is to provide empirical equations characterising the frequency behaviour trend, showing how different panels provide very similar performance and investigating the floating floor influence on impact noise reduction.

In appendix A, a list of abbreviation is provided.

## 2.1 Materials and methods

Timber floors are of various kinds, but could be divided into two categories: continuous and periodic. The first one is realized using different planks glued together until the final desired thickness is reached. The second possibility is to use glulam beams where, on top of them, boards (gypsum fibreboards, plasterboards, wooden chipboards, etc.) are secured using screws or nails.

These two kinds of structure were analysed using in situ impact noise measurements with an ISO tapping machine in multi-storey full-scale buildings. All rooms were closed using double plaster board panels or doors when available, in order to define single volumes; all tests were carried out according to ISO 16283-2 [47] using fixed microphones method with eight measures per room. All tests were repeated according to manual-scanning path technique (type 1, circle)[48] which always validated previous ones. In the first case, all measures were performed using a ISO tapping machine for 20 second each and were repeated twice. The resulting averages were used in this study.

No flanking transmission evaluation was performed since there is no need to measure or evaluate them concerning the goals of this study. These kind of buildings won't be finished at the bare structure step for fire resistance and thermal insulation issues. So always additional layers such as plaster or fibreboard with hollow spaces filled with porous materials are used in every wall. For these reasons final flanking transmissions values will change from the "bare" situation to the "final" one [49], [50].

In all figures of similar type (from fig. 5 to 9, for fig. 13 and from fig.17 to fig.21) the y-axis represent the  $L'_{n,T}$  measured or calculated levels.

## 2.2 Cross laminated structure

The tested building was a four-storey construction (Figure 1) where 16 floors were measured (Figure 2) on 16 different receiving rooms. General data of the bare buildings are reported in Table 1.

The panels were consisted of 7 cross overlapping layers providing a final thickness of 25 cm. The floor assembly was secured using a board fixed with screws and glue between panels or external walls (see Figure 3). A high density elastomeric material was included in wall-floor junctions (see Figure 4). In dwelling 4B no internal partition was present, so it could be considered as a "single room" apartment (133.5 m<sup>3</sup>).



Figure 1 - multi-storey Cross Laminated Timber building

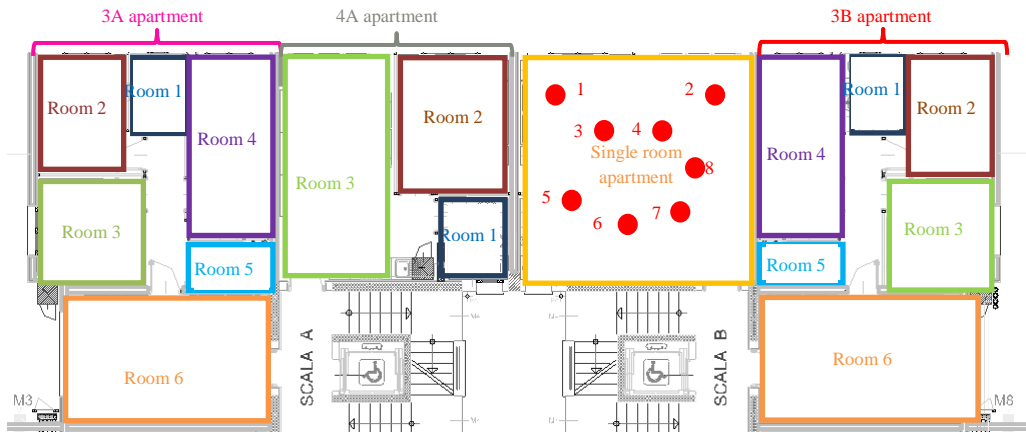

Figure 2 – standard floor map. For 3A, 4A and 3B apartments room specification are highlighted. For single room apartment measurement positions are marked, as example

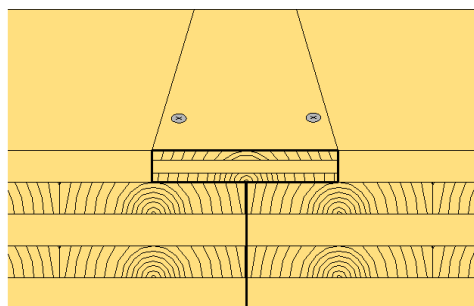

Figure 3 – floor assembly detail

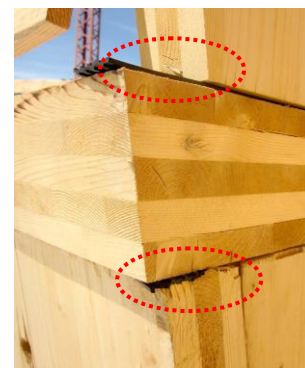

Figure 4 – wall-floor junction detail with elastomeric layer

Table 1 – General Cross Laminated Timber building data

Conditions of the partitions	Bare Cross Laminated Timber on all surfaces
Room 1 3A/3B apartment	10 m <sup>3</sup>
Room 2 3A/3B apartment	38.2 m <sup>3</sup>
Room 3 3A/3B apartment	35.6 m <sup>3</sup>
Room 4 3A/3B apartment	36 m <sup>3</sup>
Room 5 3A/3B apartment	8.1 m <sup>3</sup>
Room 6 3A/3B apartment	60 m <sup>3</sup>
Apartment 4B	133.5 m <sup>3</sup>

### 2.3 Cross laminated results

Figure 5 and Figure 6 show the results of impact noise measurements for apartments 3 A and 3 B at the frequency ranges 1000 Hz – 5000 Hz and 100 Hz – 800 Hz respectively. For these frequency ranges, final values are not influenced by the receiving room dimensions or tapping machine positions, thus indicating a great evenness of precast panels.

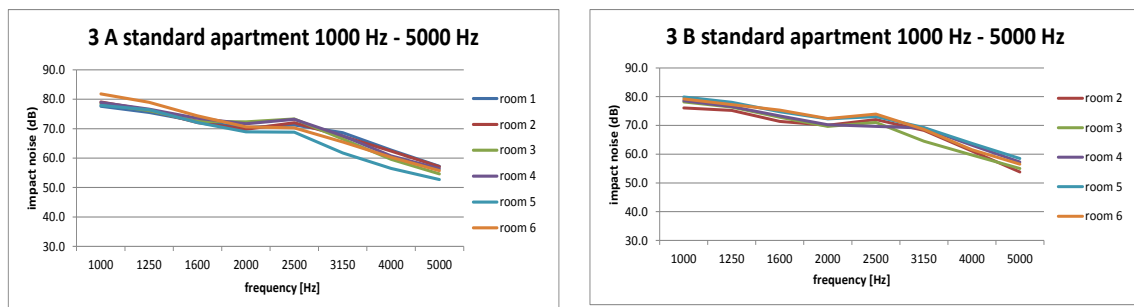

Figure 5 –high frequency trends for impact noise in apartments 3A and 3B.

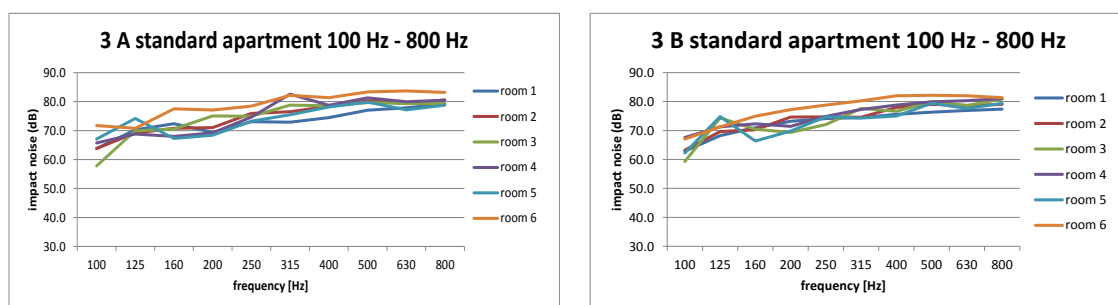
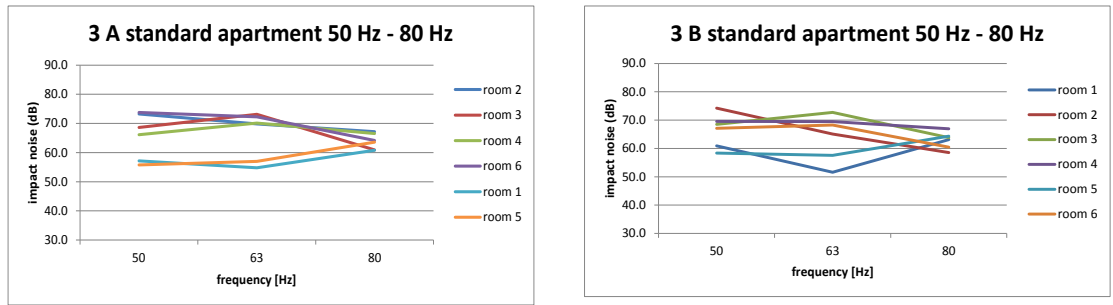

Figure 6 – middle frequency trends for impact noise in apartments 3A and 3B.

In the low frequency range (50 Hz÷80 Hz) impact noise level results could vary a lot especially in small rooms, as expected (Figure 7).

The same trends were found in the single room apartment (Figure 8 and Figure 9) where no appreciable difference was evidenced for middle and high ranges while for low frequencies no common behaviour is demonstrable.



**Figure 7 – low frequency trends for impact noise in apartments 3A and 3B**

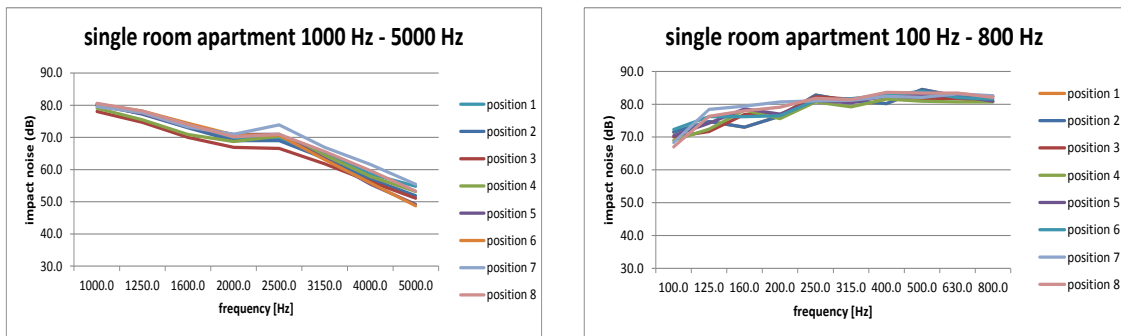

**Figure 8–trends for impact noise in single room apartment: high frequency and middle frequency**

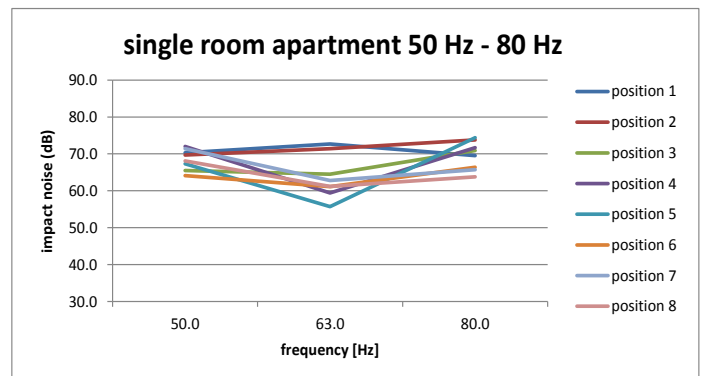

**Figure 9–trends for impact noise in single room apartment: low frequency**

For all the measured floors, the normalized impact sound pressure level provides a similar linear trend in the 1000 Hz÷5000 Hz range with a little variation around 2500 Hz (Figure 10).

In the 500 Hz – 800 Hz range the behaviour is quite similar but the level difference is quite higher. Under this threshold, a common trend with high level variations until 100 Hz is recognisable. In the lower range no common tendency is assessable.

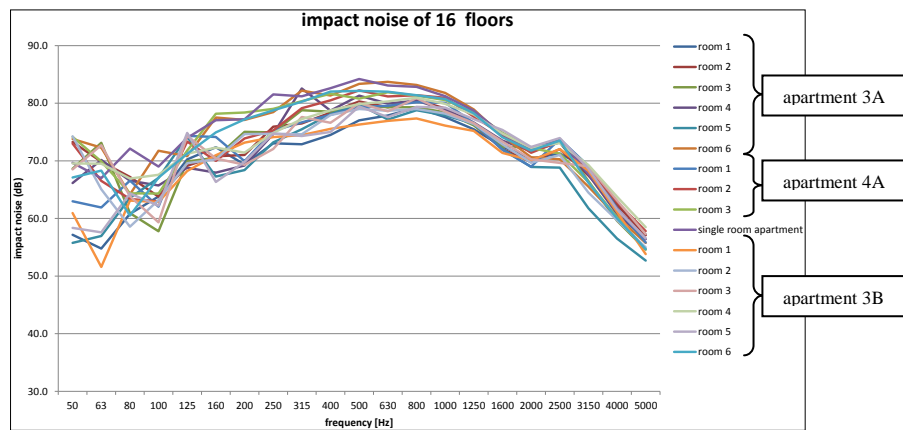

**Figure 10 –frequency trends for impact noise of 16 floors**

The increase in frequency at about 2500 Hz could be ascribed to the resonance caused by the ISO tapping machine laid directly on the wooden floor [17].

In order to compare only single index results, the weighted sound reduction index  $L'_{n,w}$  determined with ISO 717-2 method [51] as well as  $C_{1,50-2500}$  factor were calculated (Table 2). It is possible to understand once more that the single number differences are caused by low frequency range.

**Table 2 – normalized impact sound pressure index values and  $C_{1,50-2500}$  factor for Cross Laminated Timber bare floors of every tested room. Similar room are compared.**

Apartment 3A	$L'_{n,w}$	$C_{1,50-2500}$	Apartment 3B	$L'_{n,w}$	$C_{1,50-2500}$
room 1	79	-7,6	room 1	78	-7
room 2	79	-5,6	room 2	79	-6,3
room 3	80	6,6	room 3	80	-6,9
room 4	80	5,7	room 4	81	-7
room 5	78	-5,8	room 5	80	-7,3
room 6	81	-4,3	room 6	81	5,3

## 2.4 Glulam beams with top boards structure

The tested building was a three – storey construction where floors were tested on different receiving rooms (Figure 11 and Figure 12). Panels were constituted of glulam beams (18 cm thickness) connected with wooden chipboard screwed on top of them (2.2 cm thickness), mineral wool between them (10 cm thickness, 55 kg/m<sup>3</sup> density) and laterally fastened with wooden closures (Figure 13). These panels are laid in order to match the external border, so it was possible to find an air gap between them. This was filled using high sound insulation foam (Figure 14).



**Figure 11 – multi-storey glulam with top boards building**

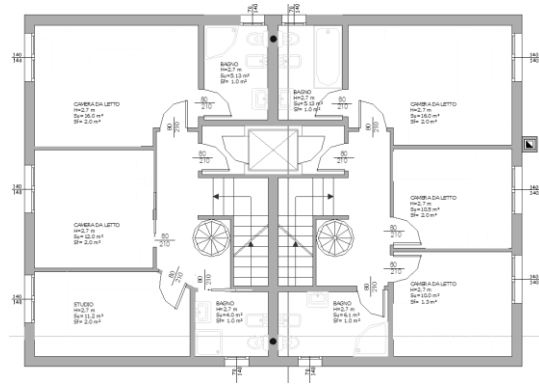

**Figure 12 – standard floor map**

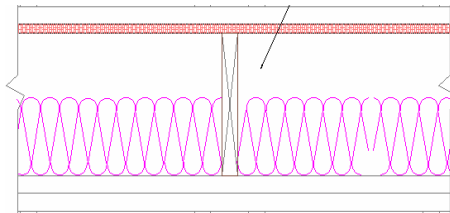

**Figure 13 – floor assembly scheme and closures detail. Materials and thickness from the top: 2.2 mm of wooden chipboard, 200 mm of wooden beams, 100 mm of rock wool density 55 kg/m<sup>3</sup>.**



**Figure 14 – high sound insulation foam insertion**

## **2.5 Glulam beams with top boards results**

As for Cross Laminated Timber structures, the same considerations could be applied here: different bare floors results are very similar due to industrial production, so here for brevity only average final values are worthy of being presented. In Figure 15 the bare floor impact noise is reported both without and with insulating foam inserted inside the air gap between panels. It is evident how the insertion makes the panels work together, thus providing more energy (more excited area) at low frequencies. Nevertheless, the airborne sound insulation performance improved. The single number value  $R'_w$  increased by 12 dB.

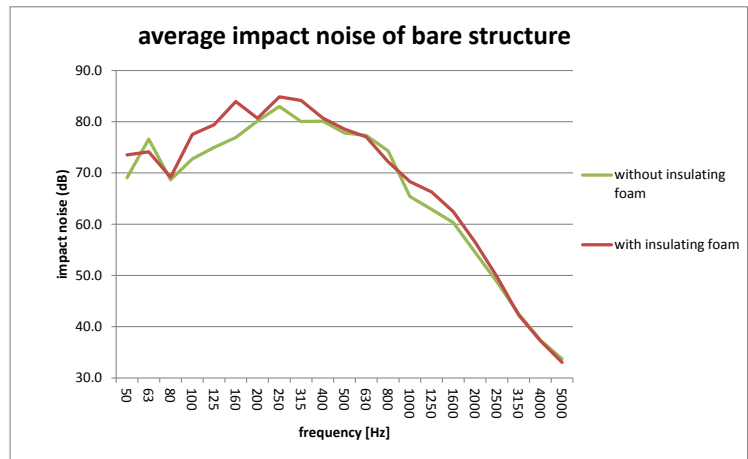

**Figure 15 – bare floor impact noise**

After these steps, a first floating floor was posed by the authors using the following layers (Figure 16):

- i. recycled cotton waste resilient layer ( $s' = 32 \text{ MN/m}^3$ ,  $d = 8 \text{ mm}$ )
- ii. marble powder in honeycomb paper panels ( $m' = 45 \text{ kg/m}^2$ )

Then a second floating floor was laid upon the first one using the following coatings (Figure 17):

- iii. recycled cotton waste resilient layer ( $s' = 32 \text{ MN/m}^3$ ,  $d = 8 \text{ mm}$ )
- iv. two gypsum fibreboards ( $m' = 35 \text{ kg/m}^2$ )

Impact noise tests using an ISO tapping machine were carried out (Figure 18) and the influence of these sound reduction solutions is reported in Figure 19.

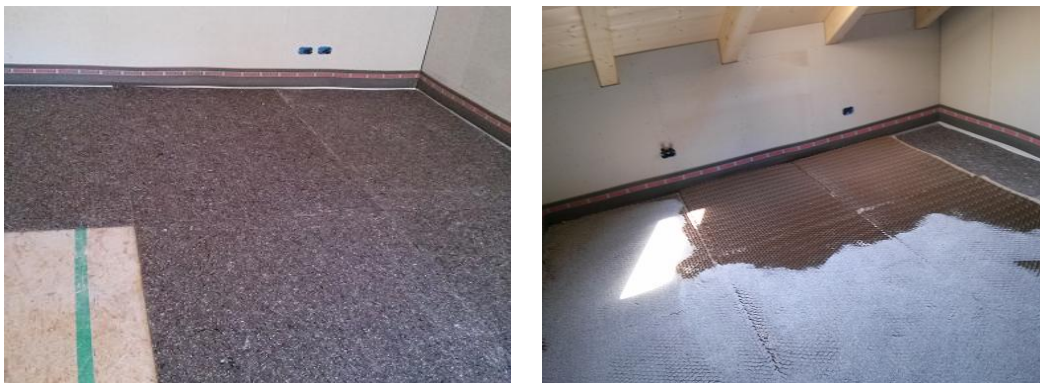

**Figure 16 – first floating floor realization**

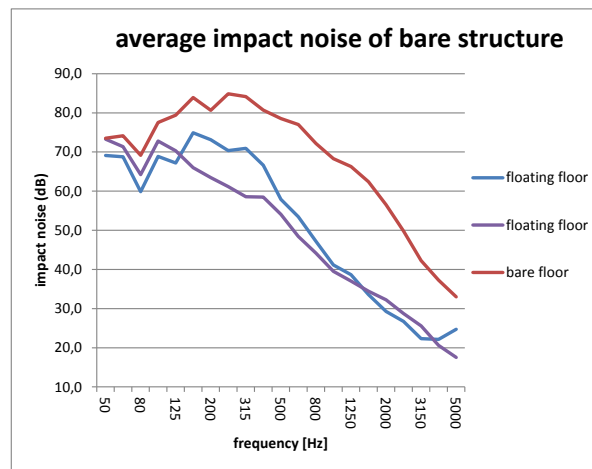

**Figure 17 – second floating floor realization**





**Figure 18 –location of tapping machine during tests: bare floor (left) and first floating floor (right)**



**Figure 19 – floating floors influence**

Afterwards, a screwed ceiling was posed. This setup implies an additional plasterboard (1 cm thickness) underneath the timber floor. It was screwed on wooden beam (50 mm thickness) with a resulting air gap of 50 mm. In Figure 20 the influence of the screwed ceiling is reported.

The worsening caused by the presence of this element is evident. At around 100 Hz its resonance frequency increases the impact noise, according to equation (4):

$$(4) \quad f_0 = 60/\sqrt{(m'/d)} \quad [\text{Hz}]$$

where  $m'$  is the mass per unit area [ $\text{kg}/\text{m}^2$ ] of the plasterboard ( $6,5 \text{ kg}/\text{m}^2$ ) and  $d$  is the distance (0.05 m) from the floor structure [m].

In order to reduce this effect, the air gap was filled with mineral wool. This operation slightly lowered the middle frequencies but did not change the resonance influence on the impact noise.

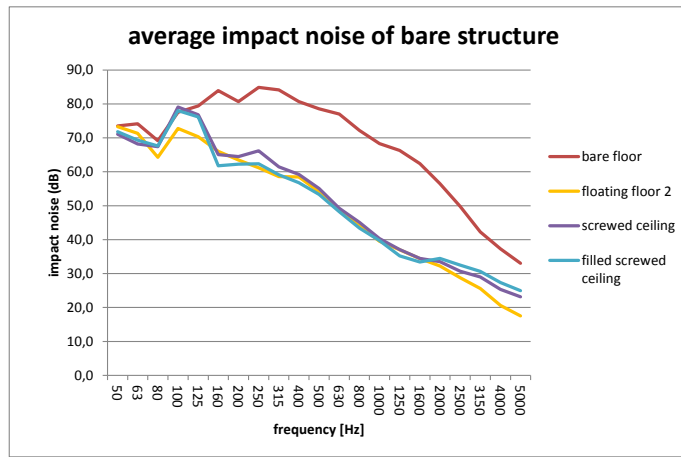

Figure 20 – screwed ceiling effect

## 2.6 Discussion of results

For the Cross Laminated Timber technology the average frequency trend was calculated using the 16 impact noise measurements reported in Figure 10. At a latter time the linear regression was calculated in order to obtain a possible predicting equation of the impact noise of bare floor. The frequency trends are reported in Figure 21.

The mean value of the frequency spectrum trend can be represented with the following equations:

$$(5) \quad L_{n,eq,avg} = -0.15 (f) + 77.7 \quad (\text{dB}) \quad \text{for } 50 < f < 80 \text{ Hz}$$

$$(6) \quad L_{n,eq,avg} = 7.26 \log (f) + 35.6 \quad (\text{dB}) \quad \text{for } 100 < f < 630 \text{ Hz}$$

$$(7) \quad L_{n,eq,avg} = -0.006 (f) + 84.4 \quad (\text{dB}) \quad \text{for } 800 < f < 5000 \text{ Hz}$$

The calculated linear regression coefficient is  $R^2=0.99$  for equation (5),  $R^2=0.89$  for equation (6) and  $R^2=0.97$  for equation (7)

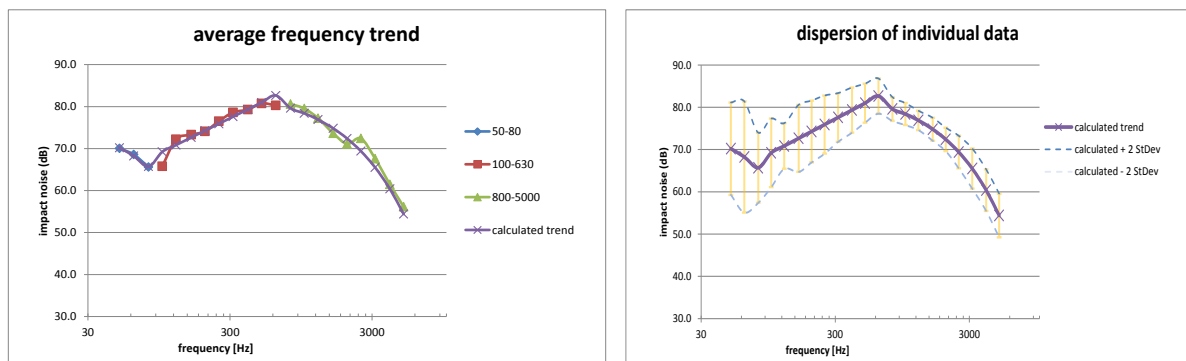

Figure 21 – Average frequency trends for impact noise and calculated linear regression and dispersion of individual data. 95% of the measured values are situated inside the

## yellow lined zone

A comparison can be carried out using the values provided by the literature for similar structures. In Figure 22 the comparison between Cross Laminated Timber and timber concrete structures is reported. It is worth to note that the influence of the concrete slab starts from middle-high frequencies according to [14].

In Figure 23 the comparison between different Cross Laminated Timber floors thickness is reported. It is evident that the influence of this parameter changes the frequency trend, altering the behaviour at almost every frequency. Nevertheless the comparison between laboratory results (Germany and Canada) shows how trends are almost the same and the difference is only depending on the thickness. This demonstrate once more the trustworthiness of measured data.

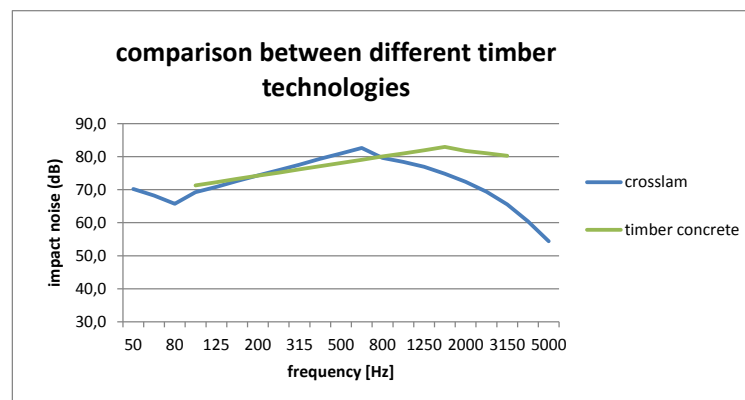

Figure 22 – comparison between Cross Laminated Timber (equation (4), (5) and (6)) and timber concrete [33] floors

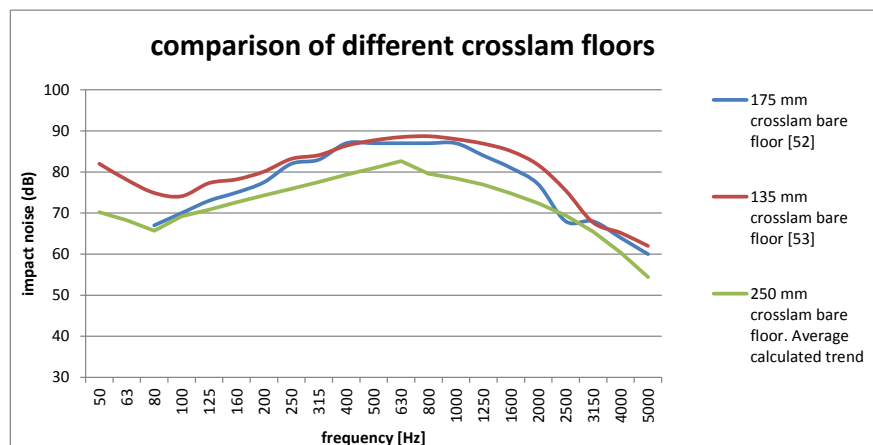

Figure 23 – comparison between different thickness of Cross Laminated Timber floors: average calculated trend (equation (4), (5) and (6)), and literature data [52], [53]

From the single index point of view, in Table 3, the normalized impact sound pressure index values, calculated according to ISO 12354-2 [9] are described. The first line reports the single index value calculated using ISO 717-2 methods [51]; for the 250 mm bare floor the frequency

trend provided by equations (5), (6) and (7) was used for calculation. No flanking transmissions were taken into account since the  $L_{nw}$  parameter was analysed (laboratory tests).

It is evident that the standard method does not provide reliable results. In fact it is suggested for homogeneous bare concrete floor with a mass per unit area  $100 \text{ kg/m}^2 < m' < 600 \text{ kg/m}^2$ . The provided results differ from the measured values up to 10.5 dB. Nevertheless, since this is the only available method, a correction is proposed according to equation (8):

$$(8) \quad L_{n,w,eq,corrected} = 134.5 - 25 \cdot \log(m') \text{ (dB)}$$

where  $m'$  is the mass per unit area [ $\text{kg/m}^2$ ] of the CLT floor. Using this method the measured and predicted results agree very well. These results are in a good agreement with literature one [50].

**Table 3 – normalized impact sound pressure index values for Cross Laminated Timber bare floors**

	135 mm bare floor [53]	175 mm bare floor [52]	250 mm bare floor eq. (5),(6),(7)
Measured $L_{nw}$	88	85	80
$L_{n,w}$ according to ISO 12354-2 model	98.5	94.6	89.2
$L_{n,w}$ according to ISO 12354-2 modified model	87.7	84.9	81.0

For glulam beams with top boards, in Table 4 the comparison between ISO 12354-2 normalized impact sound pressure index models (see equation (9)) and measured values is shown. Presented results were calculated using the average of all tests.

$$(9) \quad \Delta L_{nw, \text{single number}} = 30 \cdot \log(500/f_0) + 3 \text{ (dB)}$$

where  $f_0$  is the resonance frequency of the floating floor.

It is clear that the relation is not applicable with timber structures since the bare floors are not of infinite mass in comparison with the floating layers. The difference in mass is reduced ( $m'_{\text{bare floor}}=130 \text{ kg/m}^2$  whether  $m'_{\text{overall floating floor}}=80 \text{ kg/m}^2$ ) in comparison with a concrete bare floor ( $m'_{\text{concrete}}=600 \text{ kg/m}^2$ ) or beam and pot ( $m'_{\text{beam and pot}}=340 \text{ kg/m}^2$ ). The focus is the impact of the traditional floating floor; since the flanking transmission value are constant from bare floor to covered floor the measured final values are influenced only by the additional floating layer.

**Table 4 – floating floors normalized impact sound pressure index prediction for glulam bare floor.****Single number identification**

TIMBER	Mass per unit area [kg/m <sup>2</sup> ]	Measured Normalized Impact sound pressure index L' <sub>n,w</sub> (dB)	Predicted Normalized Impact sound pressure index L' <sub>n,w</sub> (dB)	Difference (dB)
Bare floor	130	76	--	--
Floating floor 1	45	64	54	10
Floating floor 1+2	80	58	46	12

In Table 5 a comparison of the sound reduction index of an ideal floating floor, used as example, on different structures is presented, using the frequency of Cremer's relation [10] reported in equation (9).

The floating floor is composed of a high density coating (90 kg/m<sup>2</sup>, 50 mm thickness) and a resilient layer ( $s' = 16 \text{ MN/m}^3$ ).

Here, it is evident how the same impact sound reduction solution provides very diverse performance, depending on the type of bare horizontal partition. This result depends on the different distribution of the exciting energy coming from the ISO tapping machine [54] - [58] and on the specific limit of floating floor technology: low frequency reduction.

**Table 5 – floating floor effect on same thickness different bare floor technologies using frequency Cremer's relation. Frequency trend calculation**

	Mass per unit area [kg/m <sup>2</sup> ]	Measured Normalized Impact sound pressure index of bare floor (dB)	Predicted Normalized Impact sound pressure index reduction of floating floor (dB)
Glulam	130	76	14
Concrete [59]	600	81	33
Beam and pot [33]	340	87	41

In Figure 24 the impact noise of different bare floor technologies is presented. Traditional beam and pot and timber concrete floors tested previously by the authors [33] and laboratory test of concrete one [59] provide an interesting comparison. As a matter of fact, timber based structures provide more low frequency energy (up to 20 dB) than the concrete based ones, involving a lower floating floor influence on them.

Another feature concerns the high frequency trend. Timber concrete, concrete and beam and pot structures provides energy at high frequency. This is highlighted also in hybrid cross laminated

timber bare floors (CLT with an additional concrete layer) [60],[61]. The high frequency sound pressure level is caused by the impact of the ISO tapping machine on concrete slab rising the trend and the final single index value.

The mineral wool effect on impact sound reduction is evident in glulam beams with top board partition, especially at high frequency according to [62]. Nevertheless, this range is the one in where the floating floor acts best. Once more its influence cannot be highlighted since this type of structures does not provide an ideal condition for the use of this sound reduction technology.

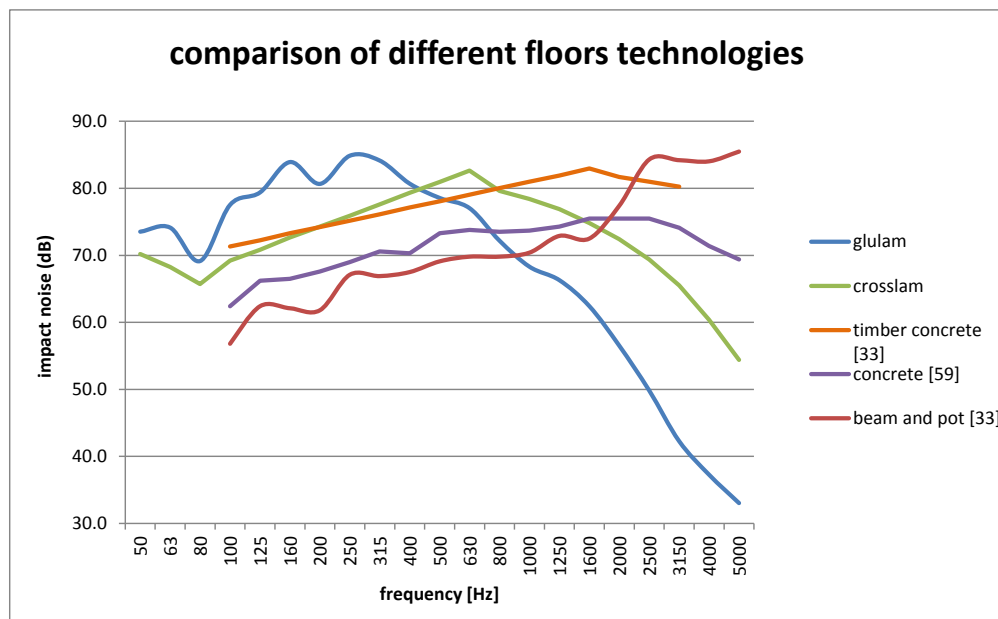

**Figure 24 – comparison of different bare floor technologies of impact noise: glulam, Cross Laminated Timber, timber concrete [33], concrete [59], beam and pot [33]**

Finally, for the extension of the proposed formula to all type of floors, the flanking transmissions have to be considered and evaluated.

In the CLT case study, the transmission paths were identified both in CLT and GLT walls (lighter than the CLT tested floors), whether in the other one only timber frame structures were present.

Connection methods of cross laminated timber element affect the radiation efficiency of the bare construction. This is basically due to the fact that in laboratory all the mounting tolerances are very controlled. But the in situ situations will be surely different since there is no control in mounting tolerances and very different screws or angle brackets could be used as evidenced by Barbaresi et al. [49]. Nevertheless, the same authors conclude that if all the differences were due to the mounting tolerances, one could draw the conclusion that in situ realizations will provide a more uniform behaviour among the panels due to the greater number of constraints [ibid.]. In other words in situ realization are less affected by fastening systems, since they are more rigid than laboratory ones.

This fact is now confirmed since from the mass ration point of view, flanking walls were various: CLT or GLT ones. Referring to Table 2, it did not seem to affect the final single number results. Hence a preliminary conclusion could be drawn: if the flanking walls are lighter than floors, then the influence of CLT and GLT flanking path difference could be very low.

As a matter of fact prISO12354-2 [63] does not include mixed structures evaluations since in section concerning the GLT technology the crosslam one is explicitly excluded. The topic of flanking transmissions in CLT-CLT constructions is implemented within pr ISO 12354-1 where a possible formulation is provided according to literature [64]. Here, no influence of the screwing or bracketing systems is described or requested, because it is almost impossible for designers to forecast how many fastening system will be used during construction and of which type, diameter or length.

Therefore, the validity of the proposed formula is limited by the assumption of similar connection conditions between the structures. To extend the results to other types of connections between nude structures also this aspect have to be considered and further investigation had to be performed.

## 2.7 Conclusions

In situ measurements on full-scale timber constructions were used to investigate the frequency behaviour of impact noise of bare floors and the influence of floating floor technology on timber horizontal partitions.

Two main typologies were analysed: Cross Laminated Timber and Glulam with screwed top boards. Results clearly indicate how the industrial production method of timber structures provides a very good repeatability and reproducibility of the measures on both technologies since all panels are manufactured, transported and assembled in the same way.

A new frequency model for impact noise of Cross Laminated Timber bare floors is proposed and validated using literature, laboratory tests and *in situ* measurements, showing a bell trend with the peak centred on middle frequencies (315 Hz – 1250 Hz).

Comparison between timber and traditional technologies is provided, showing how wooden structures irradiate up to 20 dB more energy in the low frequency range while concrete hybrid structures provide high frequency energy due to the influence of massive slab. A correction of the ISO 12354-2 model for single number prediction is proposed, related to Cross Laminated Timber structures.

Furthermore, the influence of floating floor is analysed on a GLT bear floors and a step-by-step measurement was performed after the realization of two different floating floors. The results highlight the minor impact of this technology on lightweight structures compared to the heavyweight traditional ones because of the big bare floors difference of mass per unit area.

Finally, the influence of mineral wool and screwed ceiling shows how the former acts on high frequencies and influences the effect of the floating floor, while the latter worsens the final impact noise level because of its resonance frequency. The suspended ceiling act as the best way to reduce

impact noise while the fastened ceiling act as an additional radiant layer aggravating the noise level at its resonance frequency.

### Acknowledgments

This research was funded with a Ph.D scholarship by MIUR (Italian Ministry of University) which is gratefully acknowledged.

### Author Contributions

All authors contributed equally to the conception of this study

### Appendix A

Abbreviation list

$L_n$	Resulting impact noise
$L_{n,0}$	Impact noise of the bare floor
$\Delta L$	Impact sound pressure level reduction
$f$	frequency
$f_0$	resonance frequency
$s'$	apparent dynamic stiffness per unit area
$m'$	mass per unit area
$L'_{n,T}$	Impact noise in situ measured or calculated levels
$C_{1,50-2500}$	Correction coefficient for 50 Hz – 2500 Hz frequency range
$R'_w$	Airborne sound insulation in situ measured value
$d$	distance
$L_{n,eq,avg}$	Impact noise level of regression calculation
$R$	calculated linear regression coefficient

### References

- [1] Á.Lakatos , Comparison of the Thermal Properties of Different Insulating Materials, Advan. Mat. Res. 2014, 899, 381-386
- [2] Á Lakatos, Investigation of the moisture induced degradation of the thermal properties of aerogel blankets: Measurements, calculations, simulations, Energy Build., Volume 139, 15 March 2017, Pages 506-516
- [3] L. De Geetere, B. Ingelaere, A new building acoustical concept for lightweight timber frame constructions, Proc. Internoise 2014, Melbourne
- [4] F. Ljunggren, C. Simmons, K. Hagberg, Correlation between sound insulation and occupants' perception - Proposal of alternative single number rating of impact sound, Appl. Acoust., 85, (2014) pp. 57-68
- [5] F. Ljunggren, C. Simmons, K. Hagberg, Findings from AkuLite project: Correlation



between measured vibro-acoustic parameters and subjective perception in lightweight buildings, Proc. Internoise, 2013, Innsbruck

[6] W-H Lee, K-W Kim, S-H Lim, Improvement of floor impact sound on modular housing for sustainable building. *Ren. & Sust. Energy Reviews* 2014; 29:263–75. doi:10.1016/j.rser.2013.08.054.

[7] I.L. Vér, Impact Noise Isolation of Composite Floors, *J. Acoust. Soc. Am.* 1971; 50:1043–50. doi:10.1121/1.1912726.

[8] E. Gerretsen, Predicting the sound reduction of building elements from material data, *Build. Acoust.* 1999; 6:225–34. doi:10.1260/1351010991501428.

[9] ISO 12354-2: “Building acoustics. Estimation of acoustic performance in buildings from the performance of elements. Impact sound insulation between rooms”

[10] L. Cremer, Theorie der scaldämmung wände dei schrägem eifall, *Akust. Z.*, 7 1942, 81-104

[11] R. Di Monte , M. Caniato , I. Boscarato, J. Kaspar, O. Sbaizero, Green cork-based innovative resilient and insulating materials: Acoustic, thermal and mechanical characterization, *Proc. Mtgs. Acoust.*, Volume 19, 2013, Article number 040096, 6p

[12] F. Bettarello, M. Caniato, R. Di Monte, J. Kaspar, O. Sbaizero, Preliminary Acoustic tests on resilient materials: Comparison between common layers and nanostructured layers, 20th International Congress on Acoustics 2010, ICA 2010 - Incorporating Proceedings of the 2010 Annual Conference of the Australian Acoustical Society, Volume 2, 2010, Pages 1096-1101

[13] M.A. Stewart, R.K. Mackenzie, A comparison of the predicted dynamic stiffness of resilient layers with calculated values obtained from the measured acceleration response, *Buil. Acoust.* 2000; 7:297–313. doi:10.1260/1351010001501679

[14] B. Ingelaere, D. Wuyts, Impact sound measurements on wooden floors. Project AH+, part 6, Proc. Internoise, 2013, Innsbruck

[15] A. Schiavi, C. Guglielmone, P. Miglietta, Effect and importance of static-load on airflow resistivity determination and its consequences on dynamic stiffness. *Appl. Acoust.* 2011; 72:705–10. doi:10.1016/j.apacoust.2011.03.009

[16] A. Hiramitsu, Effect of change in impact force on heavy-weight impact sound and impact characteristic of heavy/soft impact sources, *Noise Contr. Eng. J.*, Volume 59, Issue 5, September 2011, Pages 497-504

[17] J. Ryu, H. Sato, K. Kurakata, A. Hiramitsu, M. Tanaka, T. Hirota, Relation between annoyance and single-number quantities for rating heavy-weight floor impact sound insulation in wooden houses, *J. . Acoust. soc..Am.*, 129 (5), May 2011

[18] J. D. Quirt, T. R. Nightingale, F. King, Guide for Sound Insulation in Wood Frame Construction, NRC Publications Archive (NPArc) Archives des publications du CNRC (NPArc), available at <http://nparc.cisti-icist.nrc-cnrc.gc.ca/npsi/ctrl?lang=en> accessed on 22<sup>nd</sup> February 2016

[19] M. Caniato, F. Bettarello, L. Marsich, A. Ferluga, O. Sbaizero, C. Schmid, Time-depending performance of resilient layers under floating floors, *Constr. Build. Mater.* 102, 226-232

- [20] J. Medved, B. Ingeleare, L. De Geetere, Impact sound insulation concept for lightweight timber floor, *Advan. Mater. Res.*, vol 855, pp 245-251, 2014
- [21] F. Ljunggren, A. Ågren, Elastic layers to reduce sound transmission in lightweight buildings, *Build. Acoust.*, Volume 20 n.1 (2013) pp 25-42
- [22] M. Caniato, F. Bettarello, O. Sbaizero, C. Schmid, Recycled materials for noise reduction in floating floors, 22nd International Congress on Sound and Vibration, ICSV 2015
- [23] Å. Bolmsvik, A. Brandt, Damping assessment of light wooden assembly with and without damping material, *Eng. str.*, 49 (2013) 434-447
- [24] A. Hiramatsu, Y. Hasemi, T. Kaku, Floor impact sound insulation of timber three-story school building for final full scale fire test, *Proc. Internoise*, 2014, Melbourne
- [25] COST Action FP0702. Net-Acoustics for Timber based lightweight buildings and elements e-book, available at <http://extranet.cstb.fr/sites/cost/ebook/Forms/AllItems.aspx/>, accessed on 1<sup>st</sup> of may 2017
- [26] J. Negreira, D. Bard, Modelling of the tapping machine for finite element prediction tools – Preliminary parametric studies, *Proc. . ICA*, 2016, Buenos Aires
- [27] J.-L. Kouyoumji, G. Borello, H. Ferk, Reverse sea to predict flanking transmission in timber framed constructions, *Proc. ICA*, 2016, Buenos Aires
- [28] D. Bard, K. Hagberg, T. Augustsson, Modelling various floor and wall assemblies and comparisons to measured values, *Proc. . ICA*, 2016, Buenos Aires
- [29] C. Hopkins, M. Filippopolitis, N. Ferreira, Ra. Voltl, U. Schanda, J. Mahn, L. Krajci, Vibroacoustic finite element modelling of the low-frequency performance of a solid timber floor formed from dowel- connected joists, *Proc. Internoise*, 2016, Hamburg
- [30] F. Schöpfer, C. Hopkins, A. Mayr, U. Schanda, Modelling structure-borne sound transmission across a timber-frame wall using SEA, *Proc. Internoise*, 2016, Hamburg
- [31] H.-M. Tröbs, S. Schoenwald, A. Zemp, Energy distribution and sound radiation caused by the segmentation of a glulam timber floor, *Proc. Internoise*, 2016, Hamburg
- [32] <http://www.lignumdata.ch> accessed on 4th of april 2017
- [33] F. Bettarello, P. Fausti, V. Baccan, M. Caniato, Impact sound pressure level performances of basic beam floor structures. *Build. Acoust.* 2010; 17:305–16. doi:10.1260/1351-010X.17.4.305
- [34] K. Jarnerö, A. Brandt, A. Olsson, Vibration properties of timber floor assessed in laboratory and during construction, *Eng. str.*, 82 (2015) 44-54
- [35] L. Cremer, M. Heckl, B.A.T. Petersson, *Structure-borne sound structural vibrations and sound radiation at audio frequencies*, Berlin; New York: Springer; 2005
- [36] Späh M, Hagberg K, Bartolomé O, Weber L, Leistner P, Liebl A, Subjective and objective evaluation of impact noise sources in wooden buildings, *Build Acoust*, Vol. 20, n. 3 2013 pp. 193-214

- [37] J. Ryu, H. Sato, K. Kurakata, A. Hiramatsu, M. Tanaka, T. Hirota, Relation between annoyance and single-number quantities for rating heavy-weight floor impact sound insulation in wooden houses, *J. Acoust. Soc. Am.*, 129 (5), May 2011
- [38] N. Granzotto, F. Bettarello, A. Ferluga, L. Marsich, C. Schmid, P. Fausti, M. Caniato, Energy and acoustic performances of windows and their correlation, *Ener. Build.*, Volume 136, 2017, Pages 189–198
- [39] Directive 2002/91/EC of the European Parliament and of the Council of 16 December 2002 on the energy performance of buildings
- [40] M. Caniato, F. Bettarello, C. Schmid, P. Fausti, Assessment criterion for indoor noise disturbance in the presence of low frequency sources, *Appl. Acoust.* 113 (2016) 22–33
- [41] M. Caniato, F. Bettarello, P. Fausti, L. Marsich, A. Ferluga, C. Schmid, Low frequency noise and disturbance assessment methods: a brief literature overview and a new proposal, 22nd International Congress on Acoustics ICA 2016, Buenos Aires
- [42] H.G. Leventhall, Low Frequency Noise. What we know, what we do not know, and what we could like to know, *J. of Low Freq. Noise Vib. Active Cont.*, Vol. 28 No. 2 2009
- [43] H.G. Leventhall, S. Benton and D. Robertson, Coping Strategies for Low Frequency Noise, *J. of Low Freq. Noise Vib. Active Cont.*, Vol. 27 No. 1 2008
- [44] T. Watanabe and H. Møller, Low frequency hearing thresholds in pressure field and free field. *J. of Low Freq. Noise Vib. Active Cont.*, Vol. 9, No. 3, 1990, p. 106-115
- [45] M. Caniato, F. Bettarello, F. Patrizio, L. Marsich, A. Ferluga, C. Schmid, Low frequency noise and disturbance assessment methods: A brief literature overview and a new proposal, *Proc. Mtgs. Acoust.*, 28, 032001 (2016); doi: <http://dx.doi.org/10.1121/2.0000341>
- [46] G.-Q. Di., Q.-L. Lin, H.-H. Zhao, Y.-J. Guo, Proposed Revision to Emission Limits of Structure-Borne Noise from Fixture Transmitted into Room: An Investigation of People's Annoyance, *Acta Acustica united with Acustica*, Volume 97, Number 6, November/December 2011, pp. 1034- 1040 (7)
- [47] ISO 16283-2:2015, Acoustics -- Field measurement of sound insulation in buildings and of building elements -- Part 2: Impact sound insulation
- [48] C. Hopkins, On the efficacy of spatial sampling using manual scanning paths to determine the spatial average sound pressure level in rooms, *J. Acoust. Soc. Am.*, 2011, 129(5), pp. 3027-3034
- [49] L. Barbaresi, F. Morandi, M. Garai, A. Speranza, Experimental measurements of flanking transmission in CLT structures, *Proc. Mtgs. Acoust.* 28, 015015 (2016). doi: <http://dx.doi.org/10.1121/2.0000433>.
- [50] A Di Bella, N. Granzotto, L. Barbaresi, Analysis of acoustic behavior of bare CLT floors for the evaluation of impact sound insulation improvement, *Proc. Mtgs. Acoust.* 28, 015016 (2016). doi: <http://dx.doi.org/10.1121/2.0000420>

- [51] ISO 717-2:2013 Acoustics -- Rating of sound insulation in buildings and of building elements -- Part 2: Impact sound insulation
- [52] W. Byrick, Laboratory data examining impact and airborne sound attenuation in cross-laminated timber panel construction, Proc Internoise, 2015, San Francisco
- [53] IFT Rosenheim laboratory test report, n.L07, 12.11.2013
- [54] C. Johansson, Low-frequency impact sound insulation of a light weight wooden joist floor, Appl. Acoust. 44 (1995) 133–147
- [55] S. Schoenwald, B. Zeitler, T.R.T. Nightingale, Prediction of the blocked force at impact of Japanese rubber ball source, Acta Acustica united with Acustica Volume 97, Issue 4, July 2011, Pages 590-598
- [56] T. Nakao , C. Tanaka , A. Takahashi , Source wave analysis of impact force on wood based panel floor, Zairyo/J. Soc. Mater. Sc., Japan Volume 37, Issue 416, May 1988, Pages 565-570
- [57] A. Hiramitsu, Effect of change in impact force on heavy-weight impact sound and impact characteristic of heavy/soft impact sources, Noise Contr. Eng. J., Volume 59, Issue 5, September 2011, Pages 497-504
- [58] J. Brunskog, P. Hammer, The interaction between the ISO tapping machine and lightweight Floors, Acta Acustica united with Acustica 89(2):296-308 March 2003
- [59] LAB FT laboratory test report, n. 15-850-001, 20.03.2015
- [60] M. Golden, W. Byrick, Laboratory Data Examining Impact and Airborne Sound Attenuation in Cross - Laminated Timber Panel Construction - Part 2, Proc. Internoise, 2016, Hamburg
- [61] A. Homb, Hybrid cross-laminated timber floors. Comparison of measurements and calculations, Proc. ICA, 2016, Buenos Aires
- [62] J. Brunskog, P. Hammer, Prediction Model for the Impact Sound Level of Lightweight Floors Acta Acustica united with Acustica 89(2):309-322 March 2003
- [63] ISO/FDIS 12354-2, Building acoustics — Estimation of acoustic performance of buildings from the performance of elements — Part 2: Impact sound insulation between rooms
- [64] C. Guigou-Carter, M. Villot, Junction characteristics for predicting acoustic performances of lightweight wood-based buildings, Proc. Internoise San Francisco, 2015